



# STANDARDS MANUAL FOR INTERIOR WAYFINDING SIGNAGE

These standards apply to all OHSU facilities except for Doernbecher Children's Hospital. For Doernbecher Children's Hospital signage standards contact the OHSU Design and Construction department.

June 12, 2019

Prepared by

**corbindesign**

**People get lost. We fix that.™**

109 East Front Suite 304  
Traverse City, MI 49684  
231 947.1236

All ideas, designs, arrangements and plans indicated or represented by these drawings are owned by, and property of OHSU and Corbin Design and were created, evolved and developed for use on and in connection with the specified project. None of such ideas, designs, arrangements or plans shall be used by or disclosed to any person, firm or corporation for any purpose whatsoever without the written permission of Corbin Design and OHSU.

# Table of Contents

## Table of Contents

### Overview

- Summary of Changes . . . . . 3
- Style Guidelines. . . . . 4
- Interior Sign Type Array and Hanging Guidelines . . . . . 6

### Graphic Standards & Specifications

- Color & Typography . . . . . 16
- Symbols . . . . . 17
- Interior Fabrication Specifications . . . . . 19

### Directories

- D-1: Main Directory, Freestanding w/ Handheld Map. . . . . 23
- D-1a: Main Directory, Wall-mounted w/ Handheld Map. . . . . 25
- D-2: Main Directory, Freestanding . . . . . 27
- D-2a: Main Directory, Wall-mounted . . . . . 28
- D-2b: Main Directory, Freestanding, Angled . . . . . 29
- D-2d: Main Directory, Freestanding, Tall-angled. . . . . 31
- D-2c: Main Directory, Wall-mounted . . . . . 33
- D-2f: Main Directory, Wall-mounted . . . . . 35
- D-3a: Elevator Directory, Standard. . . . . 36
- D-3b,c,e,f,g: Elevator and Physician Directory . . . . . 37
- D-4b,c: Strip Map, Standard . . . . . 42
- D-5: Building/Floor Transition Sign, Wall-mounted . . . . . 43

### Guides

- G-2,a,b: Guide Sign, Standard. . . . . 45
- G-3: Guide Sign, Freestanding. . . . . 48

### Overheads

- O-1a,b: Overhead, Projecting ID/Guide . . . . . 50
- O-1c,d: Overhead, Projecting ID/Guide . . . . . 51
- O-1e,f: Overhead, Projecting ID/Guide. . . . . 52
- O-1g,h: Overhead, Projecting ID/Guide . . . . . 53
- O-2,a: Overhead ID/Guides . . . . . 54
- O-3,a: Overhead Guides . . . . . 56
- O-4a,b: Overhead, Projecting ID/Guides, Large . . . . . 57
- O-5,b: Overhead Guide . . . . . 58
- O-6,a: Overhead ID/Guide. . . . . 59

### Identifiers

- I-1b: Primary ID, Standard . . . . . 62
- I-1c: Primary ID, Standard . . . . . 64
- I-1e: Primary ID, Standard . . . . . 66

- I-2: Secondary ID. . . . . 68
- I-2a: Conference Room ID w/ Insert Holder . . . . . 69
- I-3: General Room ID. . . . . 70
- I-3a: General/Patient Room ID w/Notifier Bar . . . . . 71
- I-4,a: Patient Room ID . . . . . 72
- I-5: Utility ID . . . . . 73
- I-6: Cubicle ID. . . . . 74
- I-7: Individual Letters. . . . . 75
- I-7c: Individual Letters, Acrylic Panel . . . . . 76
- I-9: Research Bay ID. . . . . 78
- V-1-5: Vinyl. . . . . 79

### Notifiers

- N-1a,b,c,d,e,f,g: Notice Holders . . . . . 84
- N-2: General Information . . . . . 86
- N-2a: General Information . . . . . 88
- N-3: General Information . . . . . 90

### Regulatory

- Restroom Sign Standards . . . . . 92
- R-1: Regulatory . . . . . 93
- R-1a: Regulatory . . . . . 94
- R-2: Regulatory, Stairwell. . . . . 95
- R-3: Regulatory, Exit . . . . . 96

### Decorative and Custom

- Directory Signage Decorative, Construction Details . . . . . 98
- Guide Signage Decorative, Construction Details . . . . . 99
- D-2e: Main Directory, Wall-mounted, Existing Cabinet. . . . . 100
- D-3: Elevator Directory, Decorative . . . . . 101
- D-4,a: Strip Map, Decorative . . . . . 102
- G-1,a,b: Guide Sign, Decorative . . . . . 103
- G-4a,b: Guide Sign, Custom . . . . . 107
- I-1,a: Primary ID, Decorative . . . . . 108
- I-1ca: Primary ID, Standard . . . . . 110
- I-1d: Primary ID, Standard . . . . . 111
- I-8: Logo . . . . . 113
- O-5c: Overhead Guide . . . . . 114
- N-1d-alt: Notice Holder . . . . . 115
- N-1h: Notice Holder w/ Brochure Holders . . . . . 116

## Summary of Changes

---

The goal should always be to implement signs that are already in the standards, although minor changes are often required as new challenges present themselves. This page is provided to help users of the standards stay up to date with revisions that have been made over time. Any changes or deviations to these standards must be reviewed and approved by the Wayfinding Committee.

The following is a summary of changes to the standards by date:

6/2013

- Original Standards Implemented

6/12/2019

- Completely updated standards

# OHSU Style Guidelines

These guidelines adhere to AP style as a first reference and Webster's dictionary as a secondary source. The below categories touch upon common questions and issues but do not represent a full list. For more information, visit [apstylebook.com](http://apstylebook.com).

## A, b, c, d, Ph.D.

Periods are always used when abbreviating academic degrees and certifications: *B.S., F.A.A.N., M.S., M.D., Ph.D., R.N., D.D.S.*, etc. Even when an acronym/degree is long or unwieldy, the punctuation is still retained: *P.A.-C.* (AP Style makes an exception for MBA where periods are not used. These style guidelines do not follow that exception for consistency and to avoid confusion.)

These guidelines do not apply when titles are included in databases where space is constrained, or for vinyl signage applications, as vinyl punctuation is easily vandalized.

## Location, location, location

When directing to a location: First give context as to which part of town the visitor will need to navigate. Identify the campus first, followed by the parking garage, building name, elevator location, floor number and final destination.

When using postal delivery:

*OHSU  
Vein Clinic  
Mail code: L492  
3181 S.W. Sam Jackson Park Road  
Portland, OR 97239-3098*

When directing to a website: Use a link rather than giving a URL, as in *Read more about deep brain stimulation at OHSU*, with the link directing to the appropriate site. It is preferred that websites referenced in printed materials do not include <http://> at the beginning of the URL except in those instances where navigation to a site requires it. *Visit us at [www.ohsu.edu](http://www.ohsu.edu)*. Always test URLs before use to be sure they are valid.

## And and &

Use an ampersand when it is part of a company's formal name or composition title: *House & Garden, Procter & Gamble, Wheeling & Lake Erie Railway*. The ampersand should not otherwise be used in place of and.

For certain circumstances OHSU units may be granted approval to use their unit name along with the OHSU master logo. In those instances where the name is very long an ampersand can be used to replace and. However, uses in text always require spelling out and.

## Making a list and getting it right

### Bulleted lists:

- Include periods after bulleted items if those items are clauses or long phrases, or if they are short phrases that complete the statement introducing them. Do not use periods if the items resemble a shopping list, regardless of whether they complete the introductory statement.
- Capitalize the first letter of each item in a bulleted list.
- Do not use semi-colons after each bulleted item.

**Commas:** Do not use an Oxford comma in a simple series but do include it in a complex series. *He ate peas, carrots and celery. Not peas, carrots, and celery. The meal consisted of a roasted turkey that was stuffed with feta cheese and pine nuts, baked sweet potatoes with thyme, and a Brussels sprouts side dish.*

### Upper or lower: Take it case by case

**Colons:** Capitalize the first word after a colon if the word starts a complete sentence: *Then he made a promise: The research results will be available to scientists worldwide within 12 months.*

**Departments** are capitalized when referring to their proper names, but not in faculty titles referencing the specialty: *It's the Department of Pediatrics but Elisha DuBois, M.D., chairman of pediatrics.*

**Professional title:** Capitalize when a formal title directly precedes a name: *OHSU President Joe Robertson, M.D.* Do not capitalize when set off from the name by punctuation: *OHSU's president, Joe Robertson, M.D., and Joe Robertson, M.D., president of OHSU.* And don't capitalize an informal title: *ICU nurse Jane Smith.* Capitalize chairman, chairwoman as a formal title before a name: *department Chairman, Henry Ford, committee Chairwoman Margaret Chase Smith.*

Do not capitalize a casual, temporary position: *meeting chairman Robert Jones.* Use chairperson, chair or co-chair as preferred by your program or department.

A title with a signature on letterhead is the exception to the above guidelines: *Joe Robertson, M.D., President.*

Capitalize book titles and the names of newspapers and magazines. Include magazine, journal, etc. lowercase and without italics unless it's part of the publication's formal name: *Harper's Magazine, Time magazine, the journal Nature.* See the composition titles section of the AP Stylebook for further clarification.

**Headings and subheadings:** Wondering where to use capitals in a document? The table below provides some answers.

<p><b>This Heading Is in Title Case.</b> Capitalize the principal words, including verbs, prepositions and conjunctions of four letters or more.</p>	<p><b>This heading is in sentence case.</b> Only the first word is capitalized.</p>
<p>Title of a document or website: <i>NICU Services at Doernbecher, The Economic Impact of OHSU</i></p>	<p>Subhead within a document, website, publication such as brochure, poster or newsletter: <i>Find a provider, Infants younger than six months, OHSU community service</i></p>
<p>Titles in publications, such as a brochure, poster, newsletter or magazine titles: <i>You and Your Baby at Doernbecher, Community Connections, OHSU At a Glance</i></p>	<p>Headlines in press releases: <i>OHSU cures cancer once and for all.</i></p>
<p>Lecture titles: <i>The 24-Hour Clock in Human Health, The Promise of Gene Therapy</i></p>	<p>All sentences within body copy, regardless of whether they are online or printed.</p>

Although AP Stylebook does not stipulate within its guidelines where title or sentence case is used, the guidelines above represent the examples AP provides in the layout of its printed and online guides.

## Make a date to check the time

There's more to know than how many days are in each month. Capitalize every month in all uses. When a month is used with a specific date, abbreviate only Jan., Feb., Aug., Sept., Oct., Nov. and Dec. Spell out months when using alone, or with a year alone: *The lectures will be held Feb. 16 and March 22 this year.*

**When listing time of day:** *11:30 a.m., 11 a.m. (not 11:00), 12 p.m. or noon, (never 12 noon).* AP Stylebook encourages noon over 12 p.m.

## Don't carry the abbrevs. too far

In general, avoid alphabet soup. Do not use abbreviations or acronyms that the reader would not quickly recognize and do not use abbreviations or acronyms in headings and titles.

Do not follow the name of a program or other formal nouns with an abbreviation or acronym in parentheses or set off by dashes. If an abbreviation or acronym would not be clear on second reference without this arrangement, do not use it. Names not commonly before the public should not be reduced to acronyms solely to save a few words.

**Correct:** *The Center for Typed Words was formed to enlighten the public about printed communications. The center has many members.*

**Incorrect:** *The Center for Typed Words (CTW) was formed to enlighten the public about printed communications. The CTW has many members.*

Do not abbreviate department and specialty names. For example, use: *Hematology and Medical Oncology* not *Hem Onc.* Use *Obstetrics and Gynecology* not *OB GYN.*

When composing posts for social media, adhere to the style guidelines with the exception of posting to twitter. Due to the character limit set by the platform, it's acceptable to use abbreviations, use figures for numbers below 10 and use an ampersand instead of and. If your post requires more than one tweet to communicate the message, end each tweet with 1/3, 2/3, 3/3, etc. This will show readers each tweet is a part of a longer message.

## Do you take one or two words with your health care?

Two words, except in the use of a formal noun, as in *Tuality Healthcare* or *OHSU Healthcare*.

**Make your numerals count**

Spell out whole numbers below 10. *The Yankees finished second. He had nine months to go.*

Use figures for 10 or above and whenever preceding a unit of measure or referring to ages of people, animals, events or things, and also, in all tabular matter, and in statistical and sequential forms. *The law is 8 years old; the 101-year-old house.*

**Some exceptions to the below-10 rule:** Ages, weights, millions and billions (except casual uses), percentages and currency: *My 8-year-old daughter, who weighs 9 pounds, just inherited \$3 million from her aunt. A week ago she had about 5 cents to her name. I asked her to lend me a thousand at 6 percent, and she said she'd think about it.*

**At the start of a sentence:** *Forty years was a long time to wait. Fifteen to 20 cars were involved in the accident. The only exception is years: 1992 was a very good year.*

**Calling all hyphens**

Phone listings: Use hyphens after area code and prefix. Do not use parentheses around area code. For example: *503-494-8311*.

An em dash ( — ) with a space on either side is used to indicate an abrupt change in thought or an emphatic pause in a sentence.

A hyphen ( - ) is a word joiner. Use it to avoid ambiguity or to form a single idea from two or more words.

---

Questions? Contact Brand Strategy in Marketing and Communications at [branding@ohsu.edu](mailto:branding@ohsu.edu)

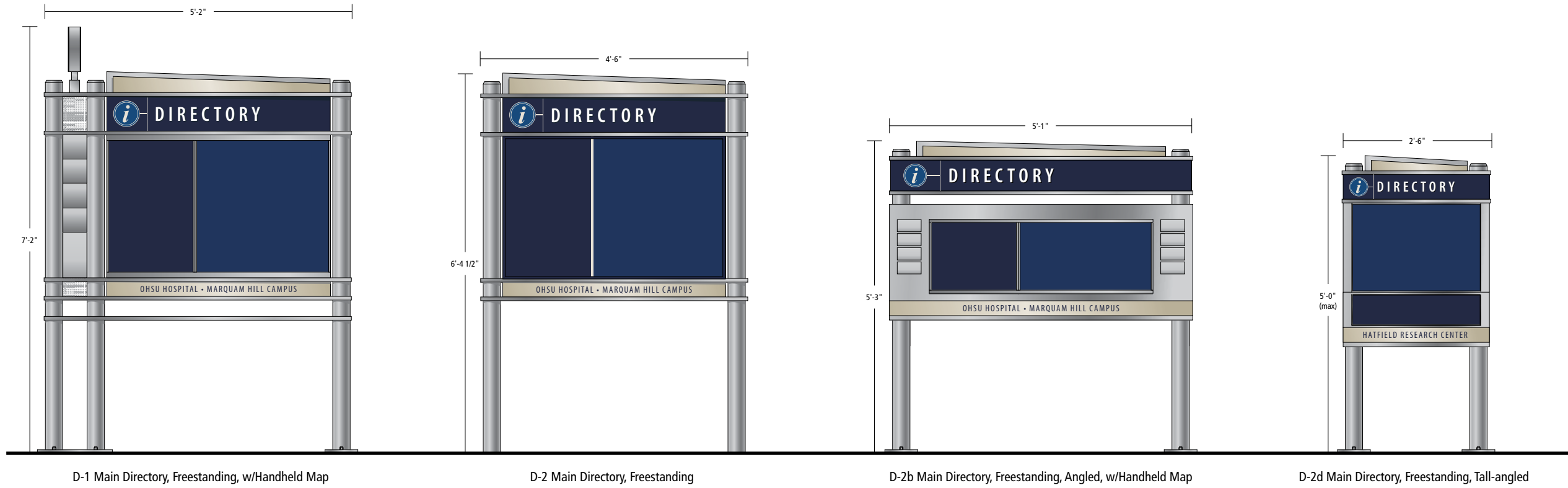

D-1 Main Directory, Freestanding, w/Handheld Map

D-2 Main Directory, Freestanding

D-2b Main Directory, Freestanding, Angled, w/Handheld Map

D-2d Main Directory, Freestanding, Tall-angled

**D-1, D-1a, D-2, D-2a-f**

Located near building entrances or at transition points between connecting buildings, these freestanding or wall-mounted directories provide the "universe of information" available to patients and visitors. The directory includes a listing of destinations accessible within that building, organized alphabetically into two sections, first destinations and then patient units. When connected to other buildings, there is a third section that includes instructions on how to access those other buildings. The directory also includes a map of the current floor showing public pathways and elevators.



The following signs are installed 70" from the top of the sign window frame to the floor. This places important wayfinding information at a standard reading level for all visitors.

D-1a Main Directory, Wall-mounted, w/Handheld Map

D-2a Main Directory, Wall-mounted

D-2c Main Directory, Wall-mounted, Simplified

D-2f Main Directory, Wall-mounted, Simplified

The following signs are installed 70" from the top of the sign window frame to the floor. This places important wayfinding information at a standard reading level for all visitors.

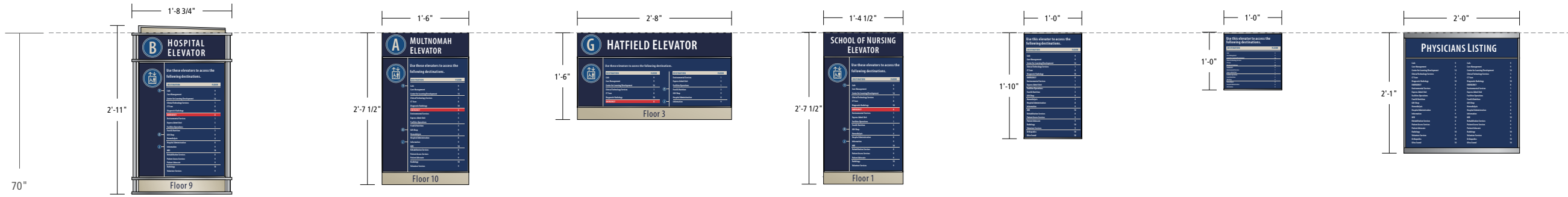

**D-3, D-3a, D-3f, D-3g**

This wall mounted sign type is located at every public elevator bank and lists the public destinations that are accessible via that elevator, along with the floor where the destination is located. The directory should be located on the same wall as the elevator doors and call buttons. Destinations are separated between public destinations and patient units, and listed alphabetically within each group.

The more decorative version of the D-3 is for use on the ninth floor of the Hospital, Kohler and Hatfield buildings only. The D-3a, D-3f and D-3g are to be used in all other locations.

**D-3b, D-3c**

These inside cab elevator directories are the same as the D-3a directories, but are located inside of the elevator cab rather than in the elevator lobby. Destination listings and organization should match the elevator directory in the lobbies.

**D-3e**

The physician directory listing is an alphabetical by last name listing of physicians. The directory can be used at a suite entrance, or at a building entrance.

D-3 Elevator Directory Decorative

D-3a Elevator Directory

D-3f Custom Elevator Directory

D-3g Elevator Directory

D-3b Elevator Directory, Inside Cab

D-3c Elevator Directory, Inside Cab

D-3e Physician Directory

The following signs are installed 70" from the top of the sign window frame to the floor. This places important wayfinding information at a standard reading level for all visitors.

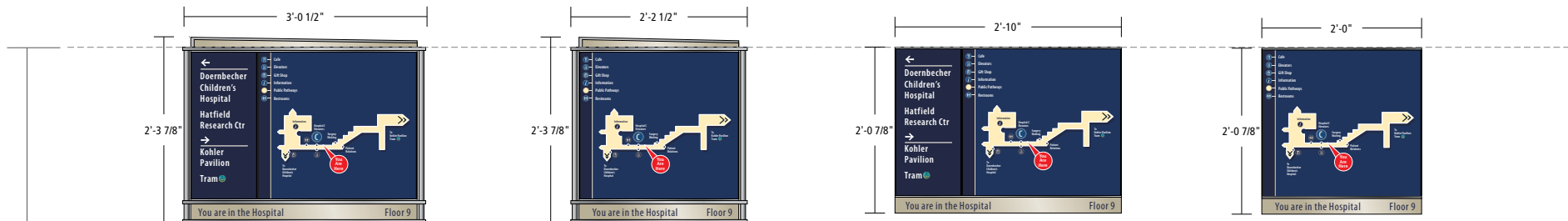

**D-4, D-4a, D-4b, D-4c**

These wall-mounted sign types indicate the current floor and depicts a simplified version of the floor plan, showing symbols and destinations that are nearby. The user's location is marked with a "You Are Here" arrow. The map should be correctly oriented to the viewer, so that the top of the map shows the direction that the viewer is facing. The D-4 and D-4b signs also contain a second insert with at-a-glance directional information for nearby buildings and the tram only. This sign type is to be used within long corridors to reinforce one's location and direction, or at complex decision points.

The more decorative version of the D-4 and D-4a are for use on the ninth floor of the Hospital, Kohler and Hatfield buildings only. The D-4b and D-4c are to be used in all other locations.

D-4 Strip Map w/Guide Info, Decorative

D-4a Strip Map, Decorative

D-4b Strip Map w/Guide Info

D-4c Strip Map

**HATFIELD RESEARCH CENTER**

Installation height and size of this sign varies depending on location. The sign cannot hang over a pathway lower than 80".

**D-5**

This custom overhead is to be used to mark when a visitor transitions from one building to another. When the building transition includes a change in floor, include the new floor information as well.

D-5 Building/Floor Transition Sign, Wall-mounted

The following signs are installed 70" from the top of the sign window frame to the floor. This places important wayfinding information at a standard reading level for all visitors.

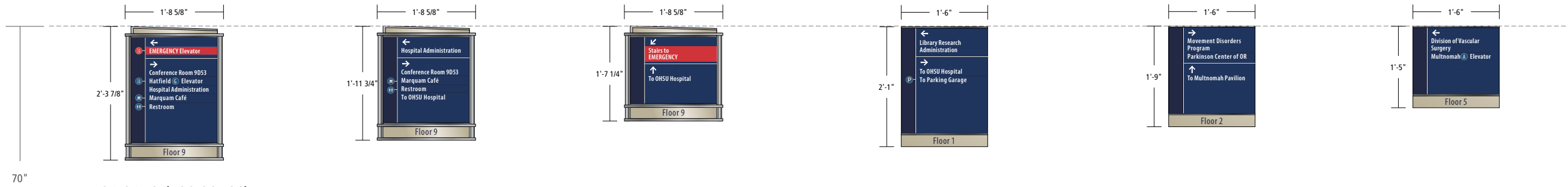

**G-1, G-1a, G-1b, G-2, G-2a, G-2b**

These sign types are used to direct to elevators and nearby primary and secondary public destinations. Guide signs are located at key decision points or within long corridors where confirmation of direction is needed. The large version of this sign frame has space for up to 11 arrow and destination lines, the medium has space for up to 9 arrow and destination lines, and the small frame can display up to 7 arrows and destination lines. Destinations shall be listed in the following order - left, right, then straight ahead. Destinations within each arrow group are listed alphabetically. If an arrow grouping includes Emergency, then that arrow group is listed first, and Emergency is the first destination.

The more decorative version of the G-1, G-1a, and G-1b are for use on the ninth floor of the Hospital, Kohler and Hatfield buildings only. The G-2, G-2a, and G-2b are to be used in all other locations.

G-1 Guide Sign, Large, Decorative

G-1a Guide Sign, Medium, Decorative

G-1b Guide Sign, Small, Decorative

G-2 Guide Sign, Large

G-2a Guide Sign, Medium

G-2b Guide Sign, Small

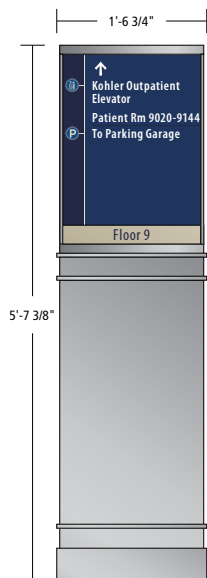

**G-3**

The G-3 sign type can be used on any floor, and is to be used in locations where a visitor needs guide information, but there is no wall space available for a wall-mounted sign.

G-3 Guide Sign, Freestanding



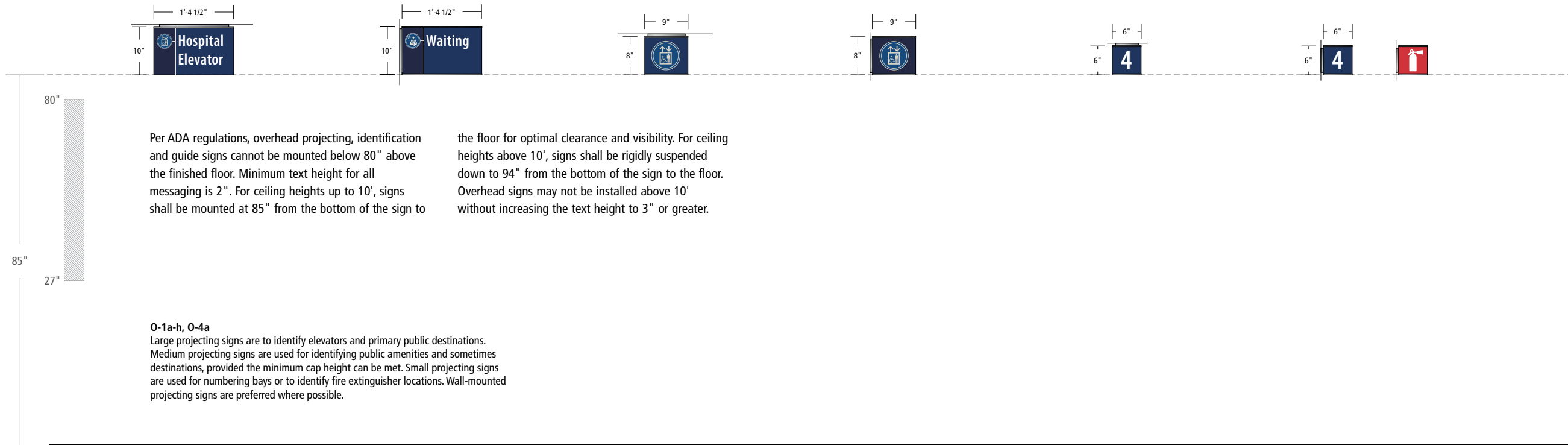

O-1a Projecting Identifier, Large, Ceiling Mount

O-1b Projecting Identifier, Large, Wall Mount

O-1c Projecting Identifier, Medium, Ceiling Mount

O-1d Projecting Identifier, Medium, Wall Mount

O-1e Projecting Identifier, Small, Ceiling Mount

O-1f Projecting Identifier, Small, Wall Mount

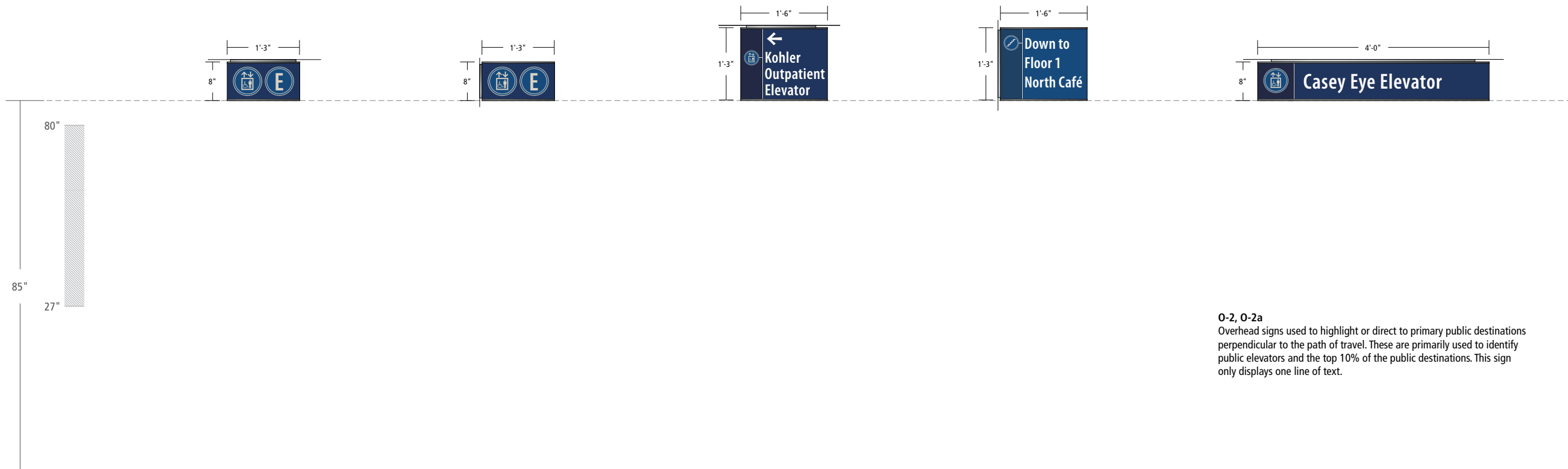

O-1g Projecting Identifier, Ceiling Mount

O-1h Projecting Identifier, Wall Mount

O-4a Projecting Identifier/Guide, Ceiling Mount

O-4b Projecting Identifier/Guide, Wall Mount

O-2 Overhead Identifier/Guide, Double-sided, Ceiling Mount  
 O-2a Overhead Identifier/Guide, Single-sided, Wall Mount

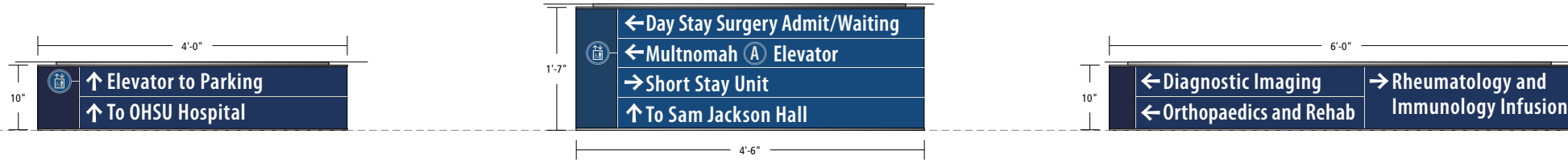

Per ADA regulations, overhead projecting, identification and guide signs cannot be mounted below 80" above the finished floor. Minimum text height for all messaging is 2". For ceiling heights up to 10', signs shall be mounted at 85" from the bottom of the sign to

the floor for optimal clearance and visibility. For ceiling heights above 10', signs shall be rigidly suspended down to 94" from the bottom of the sign to the floor. Overhead signs may not be installed above 10' without increasing the text height to 3" or greater.

**NOTE: The Mounting Guidelines included on these pages are provided as a reference only. The guidelines are an interpretation of the 2010 ADA Standards for Accessible Design, and are not to be construed as legal advice concerning compliance with any law or regulation.**



**O-3, O-3a, O-5, O-5b, O-5c, O-6, O-6a**

These overhead signs are used to direct to high-level destinations at key decision-making points where adequate sight lines are available and a wall guide at standard height cannot be used to provide the direction. Their use should be minimized as people, particularly the elderly, tend to avoid looking up for directions. The O-3 sign face can display up to two destinations, whereas the O-5 and O-5b signs can hold up to four destinations per sign face. Destinations should be listed left, then right, then straight-ahead. If both destinations are in the same direction, they should be listed alphabetically.

O-3 Overhead Guide, Large, Double-sided, Ceiling Mounted, O-3a Overhead Guide, Large, Single-sided, Wall Mounted

O-5 Overhead Guide, Double-sided, Ceiling Mounted

O-5b Overhead Guide, Double-sided, Ceiling Mount

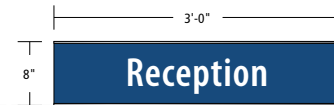
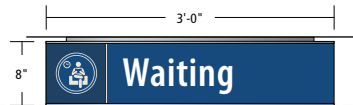
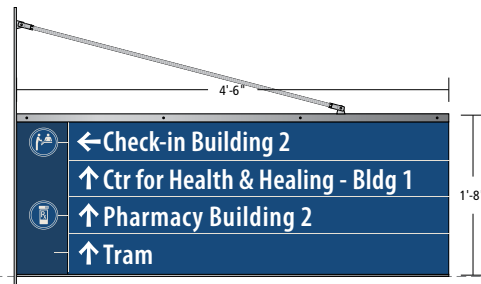

O-5c Overhead Guide, Double-sided, Projection Mounted

O-6 Overhead Identifier/Guide, Ceiling Mount

O-6a Overhead Identifier/Guide, Wall Mount

**NOTE: The Mounting Guidelines included on these pages are provided as a reference only. The guidelines are an interpretation of the 2010 ADA Standards for Accessible Design, and are not to be construed as legal advice concerning compliance with any law or regulation.**

ADA states that tactile room identification signs shall be installed on the latch side of the door (Illustration 1A). In the case of a double door, the sign shall be installed on the inactive leaf of the door (Illustration 1B). If both doors are active, then the sign is installed to the right of the right hand door (Illustration 1C). If there is no space on the latch side of the door, or to the right side of the double doors, then the sign is to be installed on the nearest adjacent wall space.

Signs with tactile characters may be installed on the push side of a door (doors that open into the room, not into the circulation space), so long as the door has a closer and is not on a hold-open device. For example, restroom doors that push open into the restroom, and the door automatically closes, may have the tactile identification sign installed on the door. This is not preferred if space is available on the latch side of the door. (Illustration 2)

Note that tactile signs must be installed such that a clear floor space of 18 inches by 18 inches, centered on the tactile copy, is provided outside of the swing of a door. (Illustration 3A and 3B)

ILLUSTRATION 1A

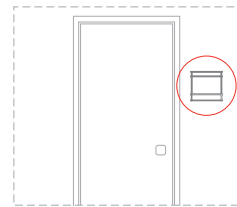

ILLUSTRATION 1B

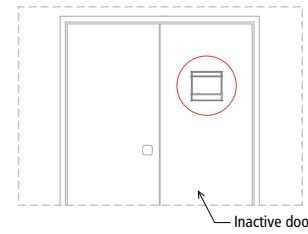

ILLUSTRATION 1C

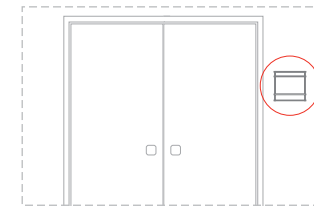

ILLUSTRATION 2

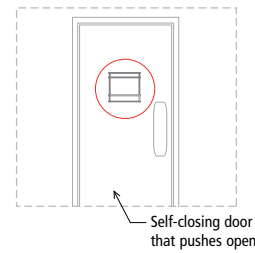

ILLUSTRATION 3A

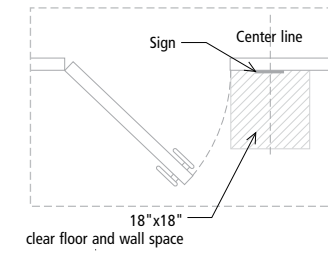
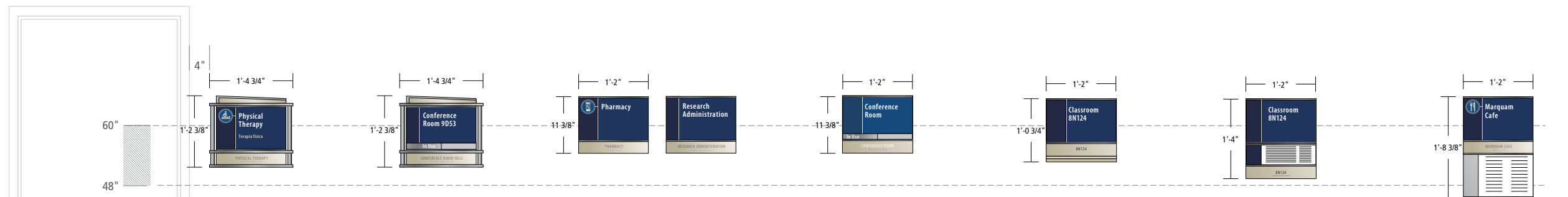
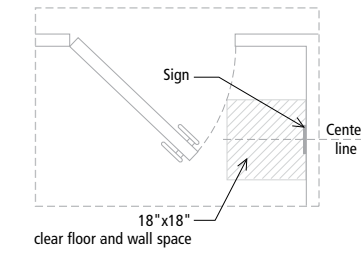

ILLUSTRATION 3B



**I-1, I-1a, I-1b, I-1ca, I-1c, I-1d, I-1e**  
 This wall-mounted sign type displays the name of a primary public destination and repeats the name in tactile and Braille lettering. Only the top 10-15% of destinations will receive this high-level sign type. This sign is to be placed at the entrance to the destination and mounted in accordance with ADA requirements. International symbols from the graphic standards page are used where appropriate.

The decorative I-1 and I-1a sign types are to be used on floor 9 of the Hospital, Kohler and Hatfield buildings only. The remaining options are for use everywhere else.

**I-1d and I-1e**  
 The I-1d includes a half-letter sized insert holder within the sign frame to allow for added messaging, such as classroom notices, hours of operations, or other special instructions. The I-1e includes a letter-sized insert holder and is similarly used for additional information that is pertinent to the patient or visitor.

I-1 Primary Identifier, Decorative    I-1a Primary Identifier, w/Slider, Decorative    I-1b Primary Identifier    I-1ca Primary Identifier w/Slider    I-1c Classroom/Lab Identifier w/Notifier Bar    I-1d Classroom/Lab Identifier w/Insert    I-1e Primary Identifier w/Letter-sized Insert Holder

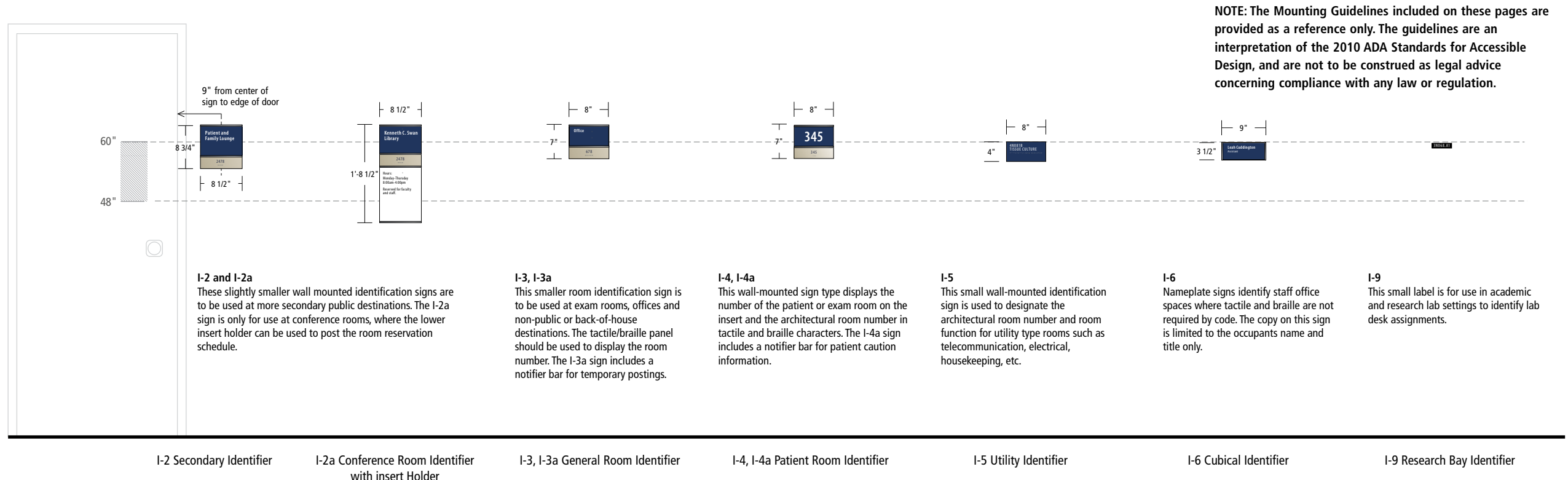

## INFORMATION AND ADMITTING



Installation height and size of these signs vary depending on location.

**I-7 and I-7c**  
The I-7 is for use at information and/or admitting desks only. The I-7c is for use at check-in desks or waiting rooms.

I-7 Individual Letters



**I-8**  
Use of this sign type must be approved by the Chief Marketing Officer.

I-8 Logo

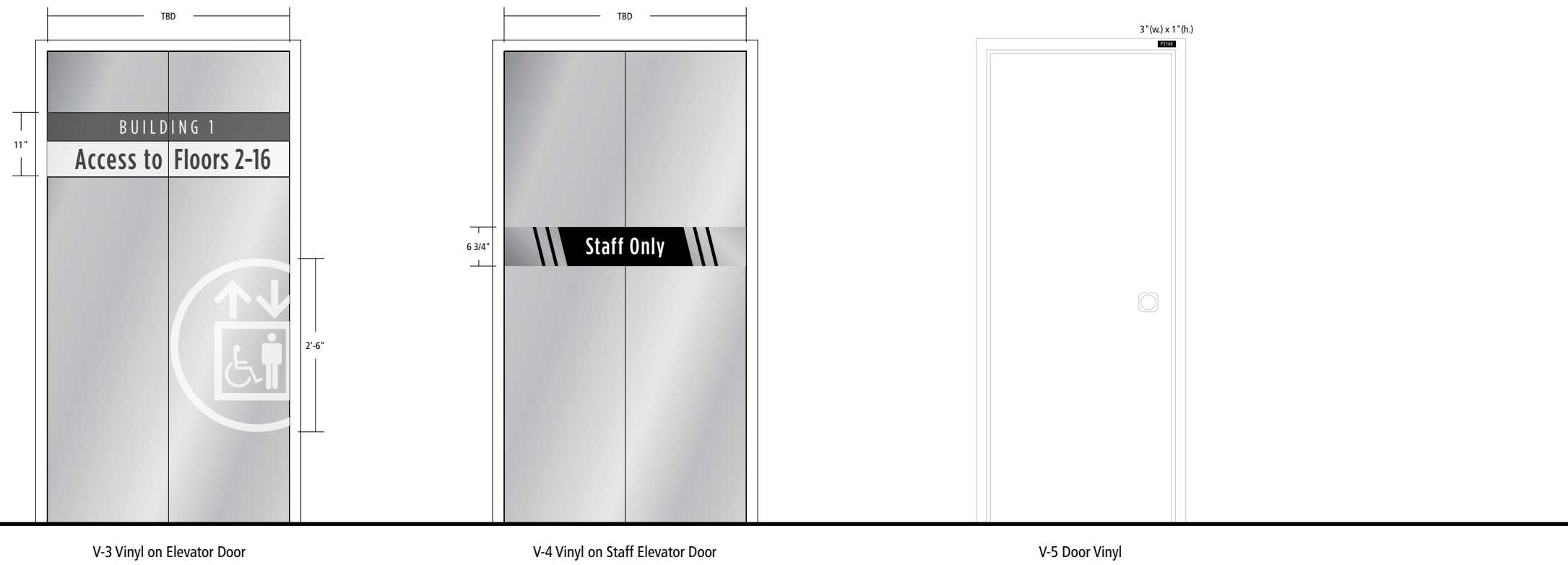

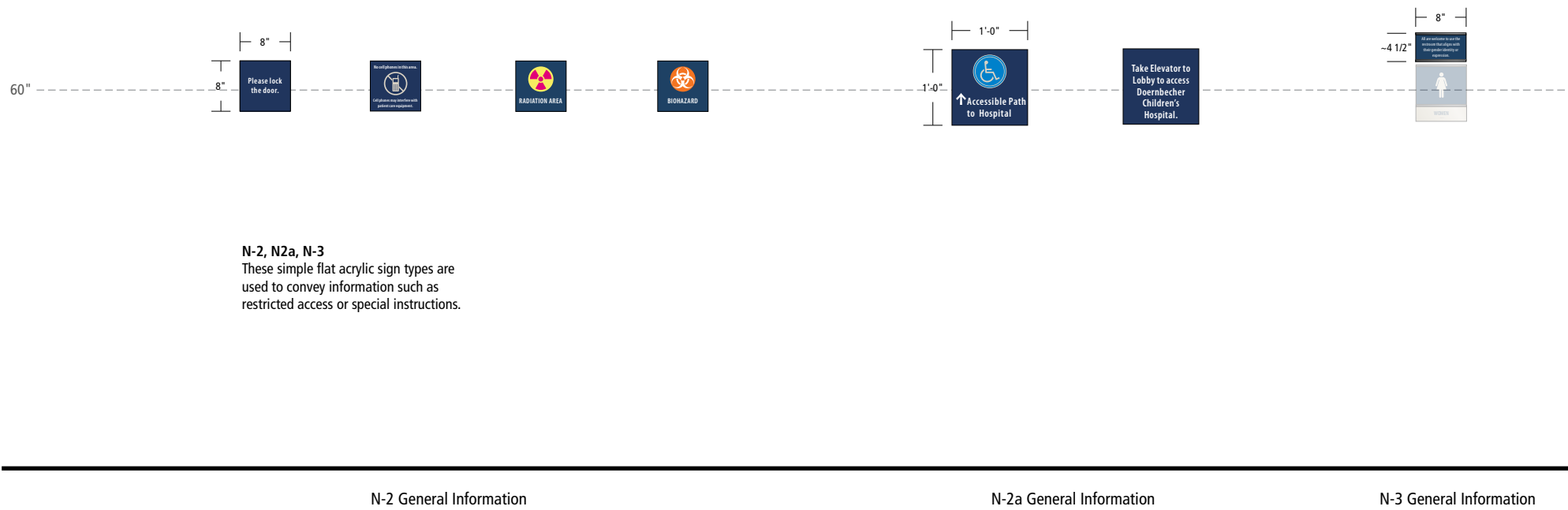
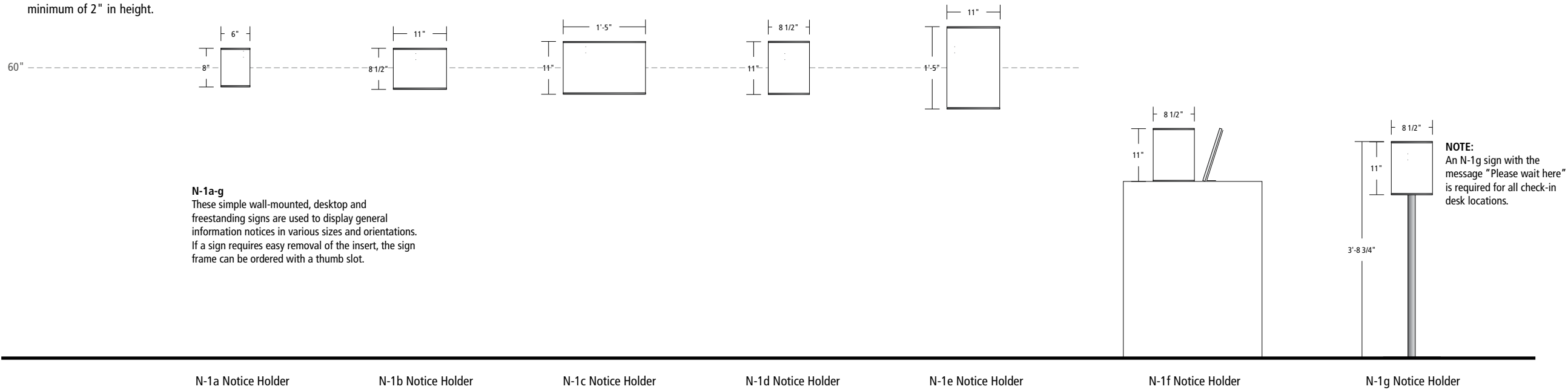

Although no mounting height is specified by ADA guidelines for a sign without tactile and braille it's recommended this sign be mounted 60" to center from the floor so that its height is consistent with other signs.  
 NOTE: Any text above 70" from the floor must be a minimum of 2" in height.

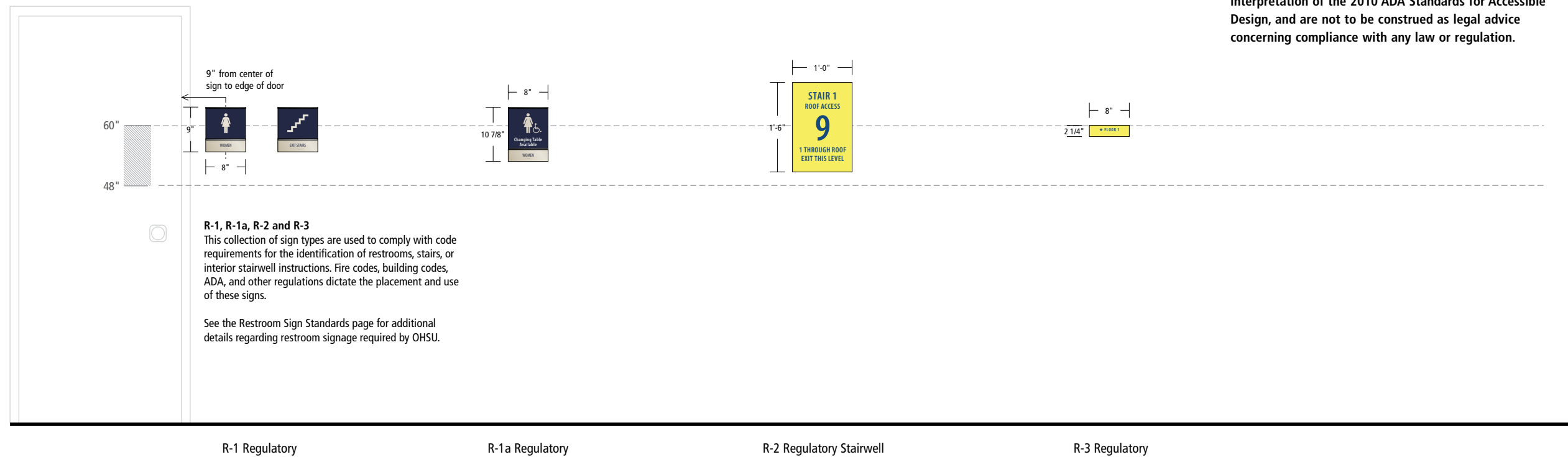



**NOTE:** The Mounting Guidelines included on these pages are provided as a reference only. The guidelines are an interpretation of the 2010 ADA Standards for Accessible Design, and are not to be construed as legal advice concerning compliance with any law or regulation.

**P1**   
**SILVER:**  
 MP18099 PLATINUM SPARKLE METALLIC  
 VINYL: 3M SATIN ALUMINUM

**P12**   
**BIOHAZARD ORANGE:**  
 PANTONE 1665

**M1**   
**CLEAR MATTE ACRYLIC**

**P2**   
**CHAMPAGNE:**  
 MP20051 SANDALWOOD  
 METALLIC

**P13**   
**RADIATION YELLOW:**  
 PANTONE 394

**M2**   
**ALUMINUM MESH SCREEN**

**P3**   
**DARK BLUE:**  
 PANTONE 533

**P14**   
**RADIATION PINK:**  
 PANTONE RUBINE RED

**M3**   
**3M DUSTED CRYSTAL ACRYLIC**

**P4**   
**LIGHT BLUE:**  
 PANTONE 534

**P15**   
**RED:**  
 PANTONE 1797



**P5**   
**BEIGE:**  
 PANTONE 7527

**P16**   
**PARKING & BARRIER FREE BLUE:**  
 PANTONE MEDIUM BLUE

**P6**   
**WHITE**  
 VINYL: 3M WHITE 7725-10  
 VINYL: 3M MATTE WHITE 7725-20

**P17**   
**DARK GREY:**  
 PANTONE COOL GRAY 11

**NOTE:**  
 Selected fabricator will need to match insert ink with APCO Cool Gray 11 ink swatch for consistent match.

**OHSU symbol**      **RLSB symbol**  
 NOTE: The colors for OHSU and RLSB symbols and sign backgrounds are different. Above are examples of how color is applied to symbols depending on the building of installation. Color should be applied to all signs within a building consistently.

○ MYRIAD PRO FAMILY:

MYRIAD PRO SEMIBOLD CONDENSED

Aa Bb Cc Dd Ee Ff Gg Hh Ii Jj Kk Ll Mm Nn  
 Oo Pp Qq Rr Ss Tt Uu Vv Ww Xx Yy Zz  
 1234567890

MYRIAD PRO CONDENSED

Aa Bb Cc Dd Ee Ff Gg Hh Ii Jj Kk Ll Mm Nn  
 Oo Pp Qq Rr Ss Tt Uu Vv Ww Xx Yy Zz  
 1234567890

Typesetting Example: Apostrophe

Typesetting Example: Ligatures

Visitor's - correct

Staff - correct

Visitor's - incorrect

Staff - incorrect

○ Fabricator is responsible for matching all colors and materials as specified and is required to provide color and material samples for approval. **CONSISTENT AND ACCURATE COLOR REPRODUCTION IN THIS DOCUMENT CANNOT BE ASSURED DUE TO THE LIMITATIONS OF COLOR PRINTING TECHNOLOGY.**

The Coated Pantone Matching System® and Matthews Paint system are used for specifying signage color matches. (In the absence of actual sign material color chip reference sets, actual specified product color swatches should be referenced for color matching.)

Shown here are approximations of the signage background colors and supporting accent colors. Actual color finishes on signage are to be matte or low luster (not shiny or glossy) and exclusively a premium acrylic polyurethane.

The font used for this project was selected specifically for this project by the Designer and Owner.

It is the responsibility of the fabricator to purchase the fonts. Purchasing information can be obtained at the following websites: <http://www.adobe.com/>

No substitution of any other typefaces may be made. Under no circumstances are typefaces to be electronically distorted ("squeezed" or "extended") for purposes of fitting to the specified sign or general alteration of the sign face composition unless noted in the drawings. This includes (but is not limited to) stretching, squeezing, tilting, outlining or shadowing.



<b>I</b> INFORMATION 	<b>UNC</b> UNISEX RESTROOM R-1/1a Signs Only 	<b>V</b> VENDING 	<b>PTRL</b> PATIENT RELATIONS 	<b>REHAB</b> PHYSICAL THERAPY 
<b>E</b> ELEVATOR 	<b>M</b> MEN'S RESTROOM 	<b>T</b> PHONE 	<b>LR</b> LACTATION ROOM 	<b>RAD</b> RADIOLOGY 
<b>B</b> ELEVATOR LETTER 	<b>BFM</b> BARRIER-FREE MEN'S RESTROOM 	<b>CAFE</b> CAFE 	<b>LD</b> LABOR & DELIVERY 	<b>CASH</b> BILLING 
<b>F</b> FOOD AND BEVERAGE 	<b>BFMNC</b> BARRIER-FREE MEN'S RESTROOM R-1/1a Signs Only 	<b>GS</b> GIFT SHOP 	<b>SURG</b> SURGERY 	<b>REG</b> REGISTRATION 
<b>S</b> STAIRS 	<b>MNC</b> MEN'S RESTROOM R-1/1a Signs Only 	<b>ATM</b> ATM 	<b>EYE</b> OPHTHALMOLOGY 	<b>MR</b> MEDICAL RECORDS 
<b>ARROW</b> ARROW 	<b>W</b> WOMEN'S RESTROOM 	<b>CHAP</b> CHAPEL 	<b>LAB</b> LABORATORY 	<b>FP</b> FAMILY PRACTICE 
<b>U</b> UNISEX RESTROOM 	<b>BFW</b> BARRIER-FREE WOMEN'S RESTROOM 	<b>IS</b> INTERPRETIVE SERVICES 	<b>AMB</b> AMBULANCE 	<b>OTPT</b> OUTPATIENT 
<b>BFU</b> BARRIER-FREE UNISEX RESTROOM 	<b>BFWNC</b> BARRIER-FREE WOMEN'S RESTROOM R-1/1a Signs Only 	<b>CARD</b> CARDIOLOGY 	<b>RX</b> PHARMACY 	<b>ICU</b> INTENSIVE CARE 
<b>BFUNC</b> BARRIER-FREE UNISEX RESTROOM R-1/1a Signs Only 	<b>WNC</b> WOMEN'S RESTROOM R-1/1a Signs Only 	<b>WAIT</b> WAITING 	<b>IM</b> INTERNAL MEDICINE 	

○ All arrows, symbols or graphics shall be produced either by photographic or computer-generated means. Hand-cut characters are not acceptable.

No substitution or creation of any new symbols may be made without prior approval. Under no circumstances are symbols to be electronically distorted ("squeezed" or "extended") for purposes of fitting to the specified sign or general alteration of the sign face composition unless noted in the drawings. This includes (but is not limited to) stretching, squeezing, tilting, outlining or shadowing.

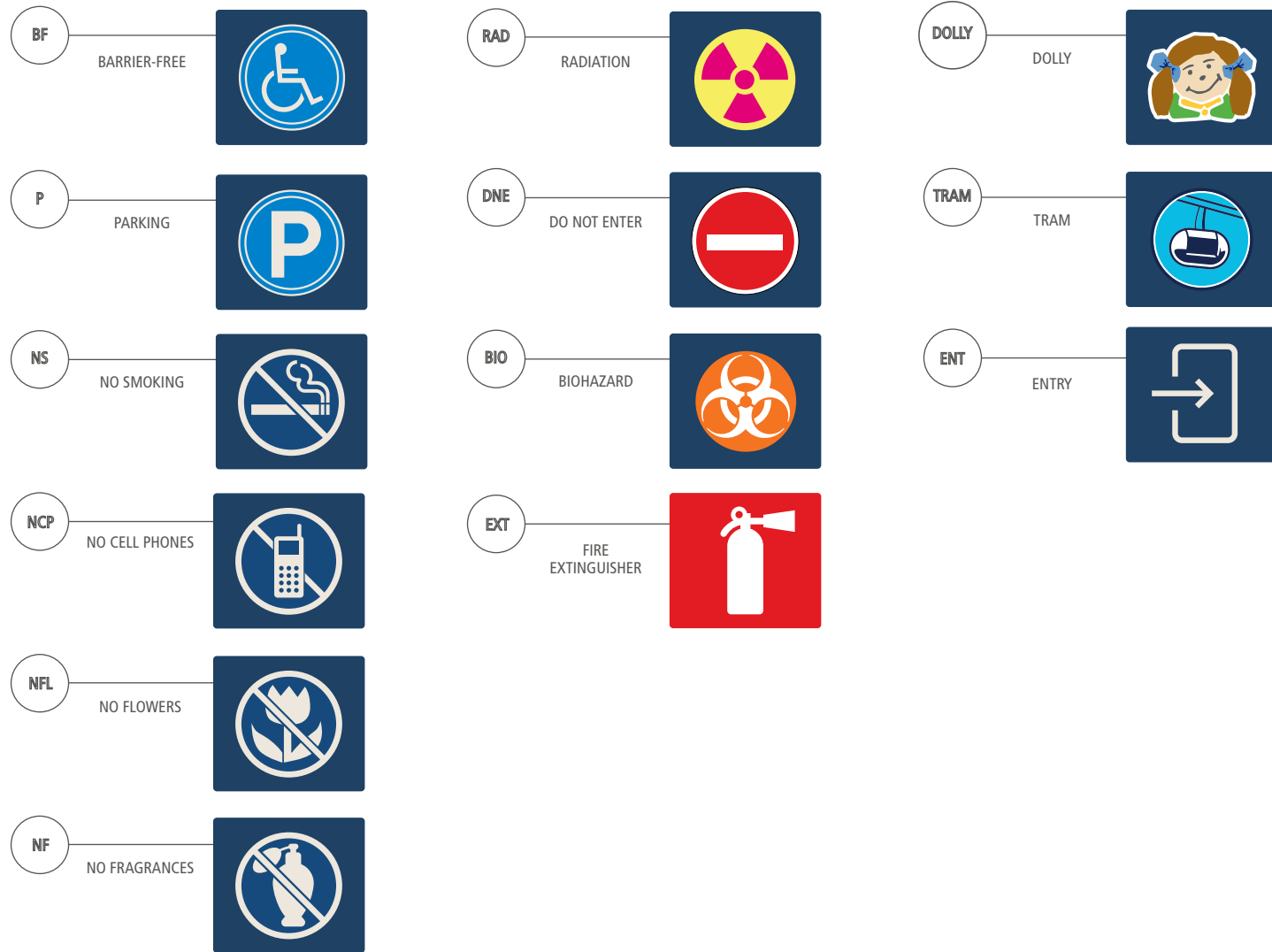

○ All arrows, symbols or graphics shall be produced either by photographic or computer-generated means. Hand-cut characters are not acceptable.

No substitution or creation of any new symbols may be made without prior approval. Under no circumstances are symbols to be electronically distorted ("squeezed" or "extended") for purposes of fitting to the specified sign or general alteration of the sign face composition unless noted in the drawings. This includes (but is not limited to) stretching, squeezing, tilting, outlining or shadowing.

**SECTION 10 14 01 – INTERIOR SIGNAGE**

**PART 1 - GENERAL**

**1.1 SUMMARY**

- A. Section includes specifications related to fabrication and installation of interior project signage.
  - 1. Sign type details are listed in the Design Intent Drawings. Design drawings are provided to the Fabricator in PDF format, or in the current version of Adobe Illustrator.
  - 2. Sign Location Plans are general in nature and not to scale. They reflect locations deemed desirable for the effectiveness of the overall wayfinding plan. Sign location plans are provided to the Fabricator in PDF format.
  - 3. The Sign Message Schedule includes sign type, exact messaging, layout details, and provides additional installation or graphic layout information specific to each sign location. Sign message schedules are prepared in FileMaker. Fabricator will be provided information in PDF format sorted by sign type and by sign number. Data is also available exported into an Excel file upon request. A link to the FileMaker database can also be supplied.
  - 4. The materials, products, equipment and performance specifications within these documents describe the standard of required function, dimension, appearance, performance and quality to be met by the Fabricator.
- B. Fabricator’s responsibilities:
  - 1. Engineer, fabricate and install all signage and graphics per the final documents provided at contract award.
  - 2. Be knowledgeable of relevant federal, state and local code requirements, and be responsible for ensuring that all signs meet current local, state and federal codes, especially, but not limited to, ADA and Fire/Life Safety codes.
  - 3. Perform complete structural design and engineering of the signs and to incorporate all the safety features necessary to adequately support the sign for its intended use and purpose, as required for approvals and permits, and to protect the Owner. All signs shall meet local, state and federal codes. Engineered shop drawings for suspended project signage and signage weighing more than 20 lbs shall be reviewed, stamped and signed by a registered engineer. Shop drawings are to be provided for all sign elements.
  - 4. Signs listed in the sign message schedule should match those on the sign location plan. Fabricator to notify the Designer and Owner’s Representative of any discrepancies before manufacturing the signage

- 5. Generate graphic layouts for all sign messages, including necessary tactile and Grade 2 Braille (conforming to the 2010 ADA Standards for Accessible Design) from the sign message schedule meeting the Design Intent Drawing specifications.
- 6. Visit the site to observe existing conditions, verify mounting conditions and space availability, take field measurements and verify all signage locations with Owner’s Representative prior to starting fabrication.
- 7. Notify the Owner’s Representative immediately if any discrepancies exist within the Construction Documents or field conditions.
- 8. Provide all submittals outlined in the specifications in a timely fashion and according to the agreed upon contract schedule.
- 9. Work with the Owner’s Representative to coordinate with other trades performing work on site.
- 10. Maintain all project related files such that the Owner may reorder additional signs for a minimum of 10 years after the completion of the work.

**1.2 WARRANTY**

- A. Extend in writing all manufacturers’ warranties.
- B. Obtain a minimum five (5) year extended warranty on all paint and powder coat applications.
- C. Obtain a minimum eight (8) year warranty on all custom color vinyl or flood-coated vinyl applications. Vinyl shall not fade excessively, discolor, crack, peel, or blister.
- D. Obtain a minimum five (5) year warranty on all applied vinyl applications. Vinyl shall not fade, discolor, delaminate, crack or curl.
- E. Provide a written full replacement warranty for five (5) years starting from the completion of installation that all signs will be free of defects due to craft work and materials including, but not limited to:
  - 1. Bubbling, chalking, rusting or other disintegration of the sign panel, graphics or of the edges.
  - 2. Corrosion appearing beneath paint surfaces of panels, brackets, posts or other support assemblies (except as an obvious result of vandalism or other external damage).
  - 3. Corrosion of fasteners.
  - 4. The assemblies not remaining true and plumb on their supports.
  - 5. Fading, chalking and discoloration of the colors and finishes within the vinyl and paint manufacturer’s stated warranty period.
  - 6. Peeling, delamination or warping (“oil canning”).
  - 7. Repair and reinstallation of signage due to failed mountings.

- F. Repair or replace, including installation, any defective signs or hardware, which develop during the warranty period and repair any damage to other work due to such imperfections at no charge to the Owner and to the Owner’s satisfaction.
- G. The Fabricator will be required to fully replace all signs that are in error relative to the working documents (sign message schedule and sign type drawings) that were submitted to the Fabricator upon award of contract.
- H. Correct any installation misalignments at no charge.

**1.3 DESIGN RIGHTS**

- A. The Fabricator is hereby granted limited right to the designs as shown and specified herein for the sole purpose of completing contractual obligations to fabricate and install project signage. Fabricator may not manufacture, reproduce or exhibit these designs, or modify them for any other purpose without prior written consent from both the Owner/ Owner’s Representative and the Designer.

**1.4 SUBMITTALS**

- A. Pre-Fabrication Submittals: Submit the following to the Owner’s Representatives and Designer for review and approval prior to commencing with signage fabrication.
  - 1. Shop Drawings: Detailed engineered shop drawings for each sign type are to be submitted as electronic PDF no larger than 11" x 17". Final Shop Drawings are to be stamped by a licensed engineer to ensure structural integrity and safety. The shop drawings for each sign type shall illustrate/describe the following:
    - a. Elevations and cross sections – front, sides, top and back; side sections; internal structure section/details; enlarged details such as of extrusions, push-through letter mounting, mounting plate; and access panel, etc.; with all final dimensions and call-outs for:
      - 1) Components – construction details/information related to individual elements
      - 2) Materials – color, type, gauge, and thickness (including substrates and overlays)
      - 3) Finishes – color, type of product, manufacturer, and sheen
      - 4) Fonts, graphics specifications and message fields
    - b. Exploded view, unless otherwise indicated – isometric view with components, materials, and finishes.
    - c. Cross-section of corners – one illustration for each corner condition. Items to be illustrated: seams, joints, layers, internal support and fasteners.

- d. Mounting/installation details – provide foundation cross-sections (including hardware), bracket/post details, elevations, materials, finishes and fasteners.
  - e. Removable panels (where applicable)
  - f. Identify any dimensional or other changes in the overall sign required by virtue of the fabrication materials, techniques and/or engineering.
- 2. Samples: Submit three (3) samples of each material listed in the design intent material specifications using actual substrate materials for review and approval. One will be returned, one kept by the Owner’s Representative and one kept in the Designer’s records.
    - a. All material samples to be 3" x 3".
    - b. Insert artwork samples to be 12" x 12", and are to be at 100% scaled segments of the final insert artwork for interior guide signs, directories and maps
    - c. Label the back of every sample with the project name, sample designation and fabricator name.
    - d. The Owner’s Representative and Designer reserve the right to reject any sample and require additional samples as necessary to obtain final approval.
  - 3. Keystroke Proofs: Provide a proofing document of final production keystroke output for all sign messages to verify line breaks, character and word spacing, and interline spacing.
    - a. The proofs are to be scaled production art files, not full sized.
    - b. Layouts are to be organized by sign type and by sign number within each sign type group.
    - c. Each layout is to be identified with the corresponding sign number.
  - 4. Schedule: Provide a detailed fabrication and installation schedule.
    - a. Include all pertinent dates and milestones such as submittal delivery dates, required approval dates, fabrication dates and installation dates.
    - b. Include all lead times for materials and third-party supplied items.
    - c. Allow a minimum of 15 business days for Owner Representative and Designer review with one round of revisions built in unless otherwise noted within the bid schedule.
    - d. Include submittal delivery dates.
- B. During Fabrication Submittals:
    - 1. Fabricator is required to maintain the detailed fabrication and installation schedule, submitting weekly updates as changes occur.

2. Upon request, Fabricator is to submit photo documentation of signage at various stages of fabrication and installation. Review of these photos does not rule out rejection of the sign during the punch list if they do not meet fabrication requirements.
- C. Post-Fabrication Submittals: Upon completion of the initial installation, the following are to be submitted to the Owner's Representatives.
  1. Maintenance instructions and manuals for all sign components (paint, etc.), along with final amended shop drawings, as-installed sign location plans and approved keystroke documents.
  2. Templates for all insert based signs, utilizing standard software for the Owner's use in printing replacement inserts.
  3. One (1) pint of each finish paint color for touch-up purposes.
  4. Labeled, spare keys to master keyed locks on directory or kiosk signage.
  5. Warranty documentation, as outlined above.

**1.5 QUALITY ASSURANCE**

- A. The materials, products, equipment and performance specifications described within, establish a high quality standard of required function, dimension, appearance, performance and quality to be met by the Fabricator.
- B. Materials used for this project shall be new materials, not reconditioned.
- C. Fabricator shall only use workforce skilled and experienced with the products, fabrication methods, and installation requirements outlined for this project.
- D. Fabrication and installation is to withstand severe abuse and souvenir theft vandalism, but not less than the equivalent of resisting simple hand implements and tools (screwdrivers, knives, coins, keys, and similar items), and adult physical force. It is the fabricator's responsibility to suggest alternate fabrication or installation methods, should they be deemed necessary to hinder theft or vandalism.
- E. Regulatory Requirements: Signage shall meet or exceed requirements of all current applicable local, state and federal codes, including, but not limited to:
  1. 2010 Americans with Disabilities Act Standards for Accessible Design, including local modifications and amendments; and
  2. Local and State Building and Fire Codes.

**1.6 DELIVERIES, STORAGE AND MATERIAL HANDLING**

- A. Pack, wrap, crate, bundle, box, bag, or otherwise package, handle, transport, and store all fabricated work as necessary to provide protection from damage by every cause.
- B. Provide clear and legible identifying information on all product packaging to ensure proper on-site identification and installation.
- C. Coordinate the delivery and secure storage of signs with the Owner's Representative to meet deadlines.

**PART 2 - PRODUCTS**

**2.1 MANUFACTURERS**

- A. Substitution:
  1. No substitution will be considered unless the Owner's Representative and Designer have received written request for approval.
  2. Equal or better equipment or method may be recommended, but will be required to provide full documentation establishing such a substitution's equality or superiority as measured in: compliance with the visual design intent, cost, ease of maintenance, and performance.
  3. The Owner's Representative and Designer's decision of approval or disapproval of a proposed substitution shall be final.
- B. Approved manufacturers include:
  1. Acrylic Polyurethane Paint: Matthews Paint Company or Akzo Nobel
  2. Interior Vinyl: 3M or Oracal
  3. Non-glare front lens: Calsak Acrycast LX or equal
  4. Acrylic Sheets: Rohm and Hass Co, Acrylite or equal.
  5. Interior Extrusions: SignComp, Charleston Industries or equivalent
  6. Adhesive Silicone: Dow Corning or equivalent
  7. Adhesive Tape: Polyfoam or "Isotac" by 3M or equivalent

**2.2 Materials**

- A. Aluminum: suitable for ornamental work. Finish to be smooth and free of imperfections. Alloy based upon structural requirements of the signage design.
- B. Aluminum sheet: .125" minimum thickness unless otherwise specified.
- C. Aluminum plate: .25" minimum thickness unless otherwise specified.

- D. Structural Steel: galvanized rolled steel or equal as required to meet structural requirements.
- E. Acrylic sheet: varying colors and thicknesses as noted on design intent drawings.
- F. Adhesive vinyl: solid color, reflective color, and transparent color.
- G. Interior grade paint: acrylic polyurethane paint in solid and metallic colors with primer and satin clearcoat finish, unless otherwise noted.
- H. Miscellaneous mounting hardware: including but not limited to, screws, bolts, steel cable, hinges, and adhesives.
- I. Fonts: purchase fonts associated with the project. See typography standards within the design package.
- J. Labels: Only labels required by law are permitted on the exterior of the sign face.
  1. Labels shall not be on the primary messaging faces of the sign, unless dictated so by the local ordinance.
  2. Labels shall be located in a position as discreet as possible.
  3. No other labels are permitted on the signs.
  4. Fabricator contact information may be placed inside the sign on the access panel.
- K. All printed graphics shall be printed at a minimum of 1200 DPI using interior grade UV inks.

**2.3 FABRICATION**

- A. Details on design drawings indicate a design approach for sign structure but do not necessarily include all fabrication details required for the complete structural integrity of the signs, including consideration for static, dynamic and erection loads during handling, erecting, and service at the installed locations.
- B. Site-verify all locations to determine special installation requirements. Field verify measurements for ceiling suspended, wall mounted and glass mounted signage, etc. prior to fabrication.
- C. Fabricate signage such that major components of the sign can be removed and replaced with similar components. Incorporate this changeability such that it does not promote vandalism, but can be done by a qualified maintenance crew.
- D. Within fabrication tolerances, allow for expansion and contraction of materials due to temperature changes as appropriate to the project location.
- E. Construction Methodology:

1. The drawings call for a variety of fabrication techniques.
2. Sign faces requiring aluminum plate of varying thicknesses, as specified on design drawings, with a minimum thickness of .125 inches unless otherwise noted.
3. Conceal all fasteners except for access panels or where approved otherwise by Owner's Representative and Designer. Access panel fasteners are to be stainless steel, tamper resistant, counter-sunk flush screws, painted to match adjacent finish.
4. All hardware and fasteners within reach shall be vandal resistant.
5. To prevent electrolysis, separate all ferrous and non-ferrous materials with a non-conductive gasket or barrier and utilize stainless steel fasteners as required.
6. Welded joints:
  - a. Exposed welded joints must be filled and ground smooth so that there is no seam visible when painted.
  - b. Dimensional and structural welding defects will not be accepted, including but not limited to: poor weld contours, including excessive bead convexity and reinforcement, and considerable concavity or undersized welds; cracks; undercutting; porosity; incomplete fusion; inadequate penetration; spatter; and non-metallic inclusions.
  - c. Welding is to be performed by AWS (or similar) certified personnel, following AWS Standard Welding Procedure Specifications (SWPSs) for steel, aluminum, and stainless steel as appropriate.
7. Non-welded joints between various portions of signs must have a tight, hairline-type appearance, without gaps. Provide sufficient fastenings to preclude looseness, racking, or similar movement.
8. Exposed acrylic edges are to be finished such that no saw marks are visible.
9. Visible metal joints must adhere to a fit tolerance of .01".
10. Sign panels shall be appropriately pre-drilled/pre-cut before priming and painting or coating.
- F. Painting:
  1. Metal surfaces are to be painted per the most recent Matthews Paint or Akzo Nobel product bulletins.
  2. Paint preparation of all metal surfaces of the sign to include removal of all scratches and imperfections, sanding and chemical etching.
  3. Substrate cleaning, preparation, paint application and paint thickness to be in strict compliance with Matthews Paint or Akzo Nobel published recommendations.
  4. Aluminum and Steel surfaces to be properly covered with a primer.
  5. Acceleration of the drying process is not allowed.

6. All paint finishes to be a satin finish unless otherwise noted in the design drawings.
7. All painted surfaces to have a clearcoat finish to add UV protection and protection from cleaning chemicals.

G. Fonts/Typefaces:

1. Fonts used within the Designer's programs were purchased by and are licensed to the Designer. It is the responsibility of the fabricator to purchase the specified licensed fonts for use within this program. See the design intent typography page for the specific fonts.
2. The fabricator is responsible for spacing the letters (Kerning) to meet ADA code requirements.
3. Letter height/cap height is based upon the height of the capital letter "E" or any capital character that has a flat top and base.
4. Under no circumstances are typefaces to be electronically distorted ("squeezed" or "extended") for purposes of fitting to the specified sign or general alteration of the sign face composition unless noted in the drawings. This includes (but is not limited to) stretching, squeezing, tilting, outlining or shadowing.
5. Ligatures are to be turned off.
6. Apostrophes and quotation marks are to be used, not footmarks and inches. Note that there is a difference in most fonts.
7. Fabricator to reference spacing within the Design Intent Drawing package. Layout of copy is critical for the proper function of the wayfinding signage. Any typesetting concerns or issues are to be brought to the Designer for resolution recommendations.
8. Fabricator is responsible for correcting any typesetting errors that may be necessary.
9. All tactile and grade 2 Braille characters are to be created using the photopolymer or raster dot methods as dictated by code requirements.

H. Silk-screen, digital printing and vinyl copy:

1. All letterforms, symbols or graphics shall be reproduced either by photographic or computer-generated means.
2. Cutting shall be done such that edges and corners of finished letterforms will be straight, sharp and true.
3. Letterforms with nicked, cut, ragged, rounded corners, and similar disfigurements will not be acceptable.
4. Copy is to match the sheen of the copy panel background (satin).
5. Surface of letters shall be uniform in color finish, and free from pinholes and other imperfections.
6. Silk-screened images shall be executed with photo-processed screens prepared from original electronic art.
7. Use only weather-resistant coating materials that are compatible with substrates.

8. Silk-screening shall be highest quality, with sharp lines and no sawtooths or uneven ink coverage.
9. Images shall be uniform in color and ink thickness.
10. Images shall be free from squeegee marks and lines resulting from improper print stroke or screen off contact height.

**PART 3 - EXECUTION**

**3.1 DEMOLITION**

- A. It is required that the fabricator remove existing signs as identified in the bidding documents.
- B. Fabricator is responsible for repairing and repainting all surfaces damaged through the removal of the existing signage. Owner's Representative will provide material specifications for matching existing surfaces.
- C. If there are electrical connections, they must be properly terminated.
- D. Fabricator is responsible for disposal of existing signage. Recycling is recommended. Open dumping is prohibited. Coordinate with the Owner's Representative.

**3.2 INSTALLATION**

- A. Review all sign locations with the Owner's Representative and ensure that every location has the necessary blocking for safe and secure mounting. Where additional blocking is needed, recommend changes and additional associated costs, and receive approval prior to beginning installation.
- B. The final Sign Message Schedule and Sign Location Plan shall be consulted together and shall be approved by the Owner to determine the precise location for each sign. Any necessary adjustments will be made with the approval of the Owner.
- C. If installation subcontractors are utilized, the Fabricator must provide a company representative to act as on-site supervisor through the duration of the installation process to oversee any subcontracted installation work.
- D. Fabricator to maintain current signage and directional information during installation in order to continue to provide proper wayfinding. This can be done through the use of temporary signs or temporary mounting of existing signs while walls are repaired.
- E. Fabricator to coordinate delivery of signage with the Owner's Representative.
- F. Fabricator to provide a site logistics plan indicating the work areas, proposed equipment and power sources, and schedule time/dates of the respective sign installations. This schedule

is to be updated on a weekly basis if changes occur.

G. Mounting:

1. All signs to be mounted level and true, and within the guidelines of applicable local, state and federal codes including, but not limited to, the 2010 Standards for Accessible Design (ADA) and fire/life safety codes, where applicable.
2. For all bolts, nuts, washers and other fasteners, Fabricator to use same basic metal or alloy as the metal being fastened and finished to match. When fastening dissimilar materials, use stainless steel 300 series.
3. Fabricator is required to specify mounting hardware and anchoring per the engineering of the signage. The visual appearance of the sign is not to be compromised from that shown in the design drawings.
4. Install all signage products such that there are no misalignments between visible components. Sign elements intended to be removable or changeable after installation must function as intended without binding, sticking or blocking.
5. OHSU will not allow substitutions pertaining to VHB tape. OHSU has specifically requested that when VHB tape is used, the fabricator will be required to use 3M VHB Grey tape based on its performance and past experiences with this product.

H. Locating Signs:

1. Fabricator's installers must have applicable understanding of the 2010 Standards for Accessible Design (ADA) mounting guidelines, city zoning and other applicable federal, state and local codes, general sign locating practices, and any particular unique installations.
2. Installers are to follow the regulations, noted guidelines, comments within the Sign Message Schedule and architectural details around an installation location for the best visual placement.
3. Keep a reasonable distance from protruding objects.
4. Any signage that is improperly located is to be moved to the proper location, and all repairs to wall surfaces and signage are to be handled by the Fabricator.
5. If the installers are unable to make a decision about any sign locations, they can contact the Designer, providing a graphic representation of the questionable area, or contact the Owner's Representative for on-site options. If there is a code requirement regarding the sign location, the installer must notify the Owner's Representative of the requirement.

- I. Upon completion of installation prior to final punch list, Fabricator is to remove any protective covering, tape, or installation hardware. Fabricator is then to clean the sign per the manufacturer recommendations, ensuring that sign is clean from dirt, stains, fingerprints, tape residue, etc.

- J. All exposed hardware is to be touch-up painted on site as required immediately following installation prior to punch list.
- K. All minor blemishes or marring are to be repaired such that the repairs are imperceptible. Components having permanent, non-removable scratches or defects are to be replaced completely.
- L. Site Safety and Restoration:
  1. Fabricators are responsible for their own safety during the installation period.
  2. Maintain a safe environment for pedestrians during the installation period, following OSHA safety standards as necessary.
  3. Keep the Owner's premises and the adjoining premises, driveways and streets clean and clear.
  4. Job site shall be left safe, neat and clean at the completion of each day's operation.
  5. In addition to maintaining old or temporary signs for their directional or informational purposes, Fabricator is to maintain signage that meets or exceeds local standards during the installation period.
  6. At the completion of work, remove all rubbish, tools, equipment, tape and surplus materials, from and about the premises, and leave the site as originally found.
  7. Repair or correct damage to other contractors' work resulting from signage installation work.

**3.2 PUNCH LIST**

- A. The Fabricator's onsite representative is to complete a walk through with the Owner's Representative immediately following installation to identify any errors, such as construction or installation issues. Such errors are to be corrected in a timely manner, and to the satisfaction of the Owner's Representative.
- B. Fully replace all signs that are in error relative to the working documents (final sign message schedule and design drawings).
- C. Correct any installation misalignments at no charge.
- D. If the Fabricator agrees to a timeline for the Designer's punch list trip, and then does not complete their scope of work in time for the site visit, requiring the trip to be delayed, the Fabricator will be responsible for associated charges in rescheduling.

**END OF SECTION**

## DIRECTORIES

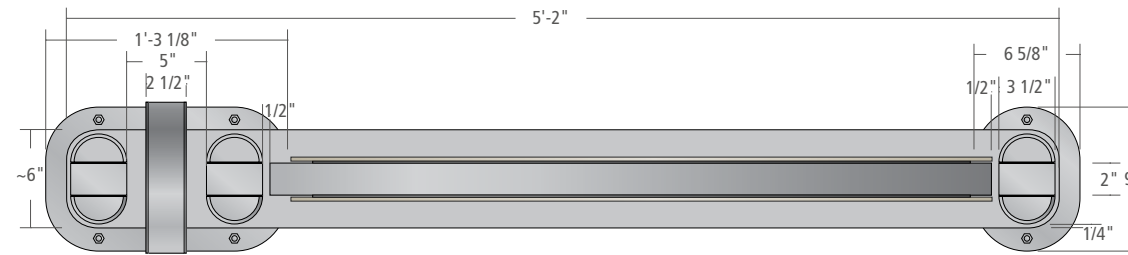

TOP VIEW

Custom fabricated, double-sided cabinet with painted custom radius aluminum support poles.

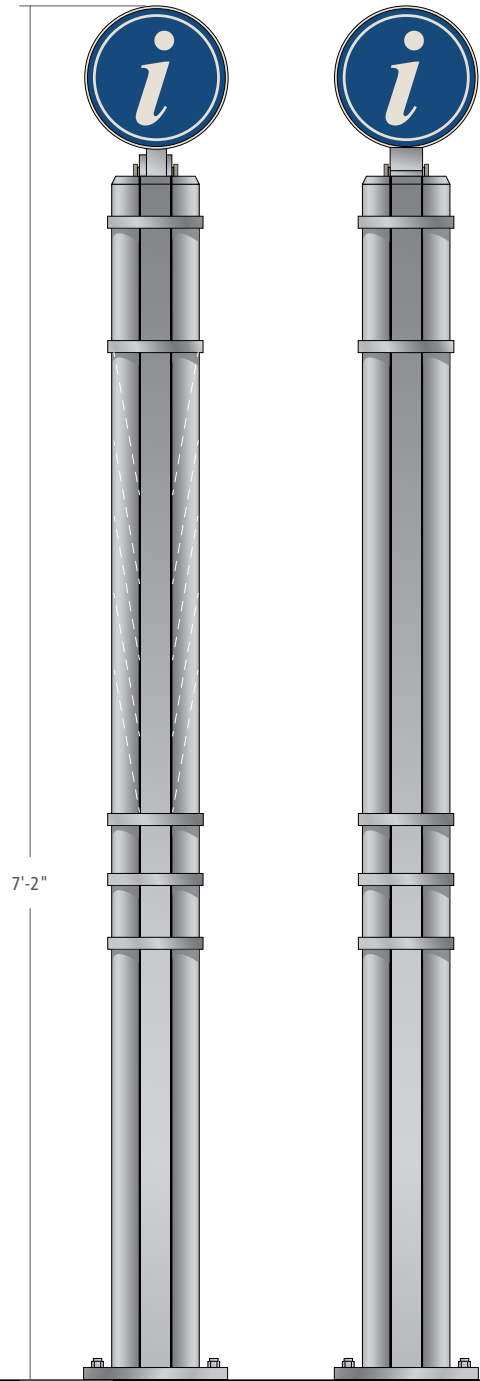

Custom fabricated cabinet with vinyl symbol. Cabinet is double-sided.

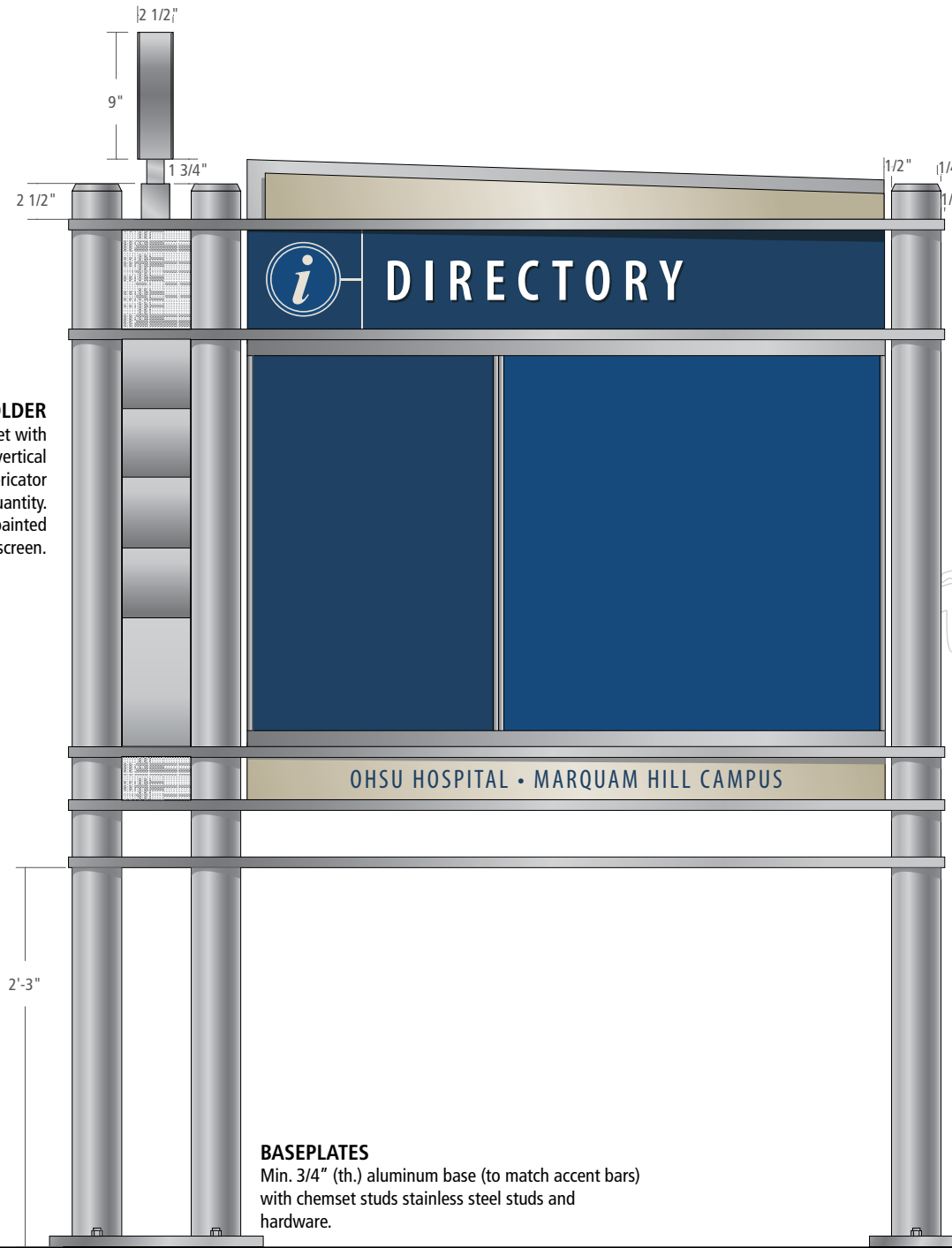

**HANDHELD MAP HOLDER**

Custom fabricated cabinet with angled slots to hold folded vertical 8.5" x 11" brochure inserts. Fabricator to engineer insert slots and quantity. Background of cabinet is a painted mesh screen.

**DECORATIVE HEADER**

Custom fabricated cabinet with painted acrylic panels. Acrylic panels are mounted 1/8" off cabinet. 1/8" spacer should not be visible.

**DIRECTORY HEADER**

Custom fabricated cabinet with a silk-screened header. Header should surface align with with angled metallic silver decorative header above.

**ACCENT BARS**

3/4" (th.) painted aluminum accent bars welded to support poles.

**DIRECTORY CABINET**

APCO FullView Large Assembly sign - horizontal configuration with vertical divider bar. Mounted to central support, signs should be flush with Header above. Large format printed inserts sit behind matte acrylic lens. Inserts should fit tight against acrylic window for optimal appearance. Window is removed from frame with a suction cup tool using a lift/pull technique. 3'-9" w x 2'-5" h

**DECORATIVE FOOTER**

Custom fabricated cabinet with painted acrylic panels. Panels should align with insert windows above.

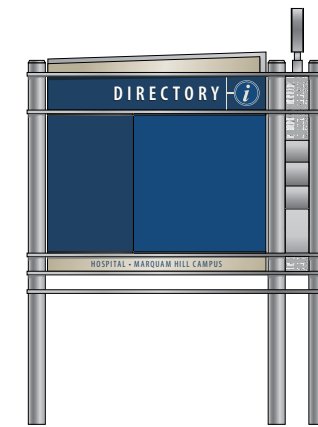

OPPOSITE FACE

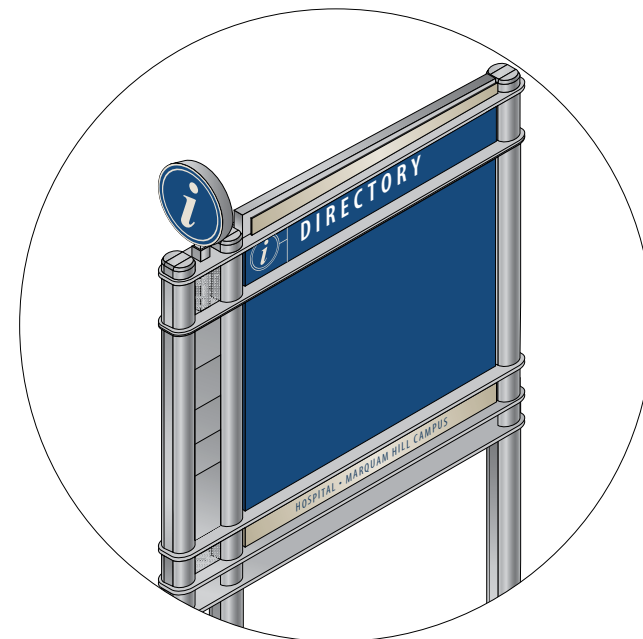

**BASEPLATES**

Min. 3/4" (th.) aluminum base (to match accent bars) with chemset studs stainless steel studs and hardware.

**D-1 MAIN DIRECTORY, FREESTANDING, w/HANDHELD MAP**  
Scale: 1"=1'-0" on an 11" x 17" sheet

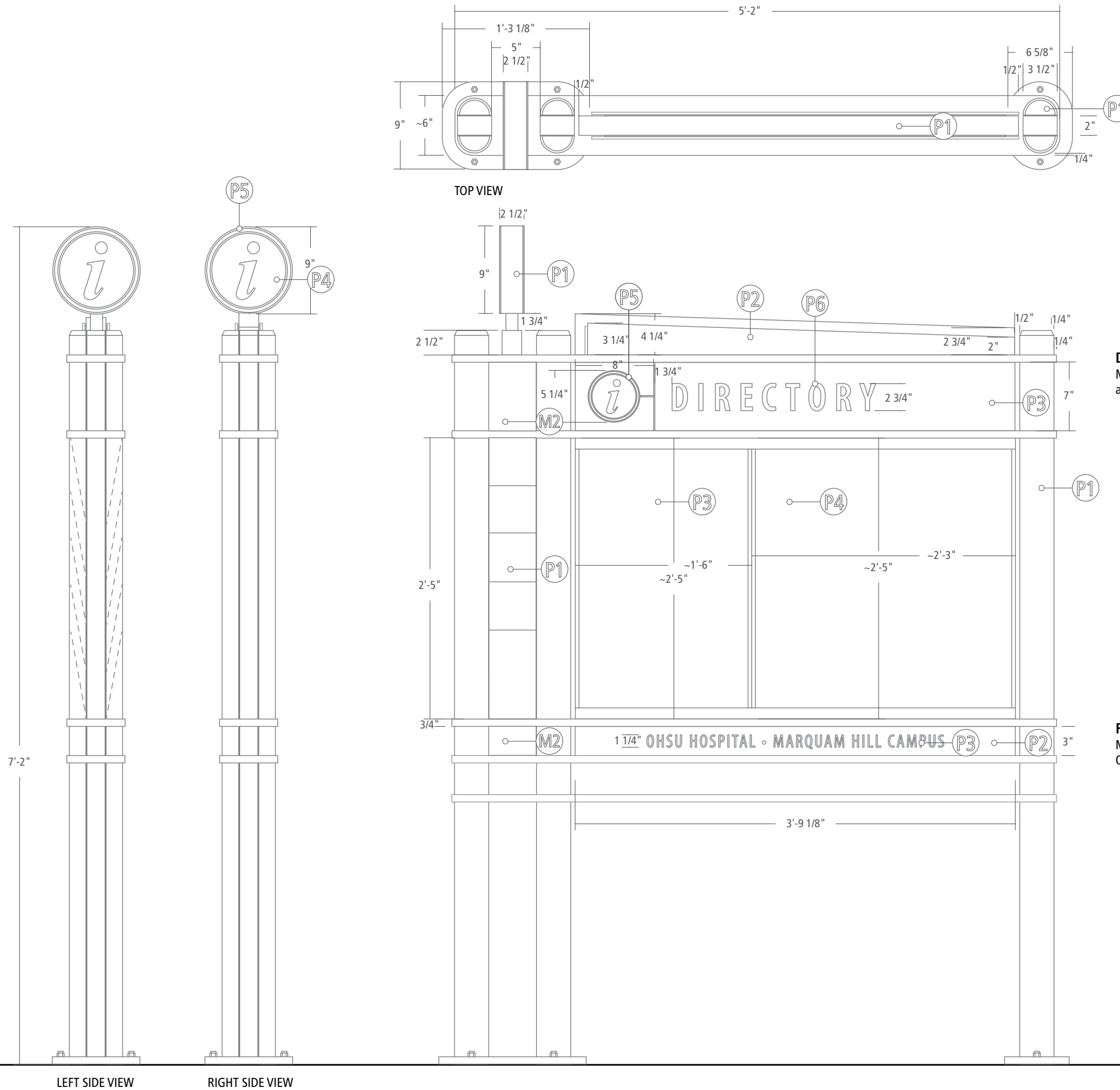

**DIRECTORY**  
Myriad Pro Semibold Condensed, kerning set for Optical at 200%

**FOOTER**  
Myriad Pro Condensed, all capital letters, kerning set for Optical at 100%

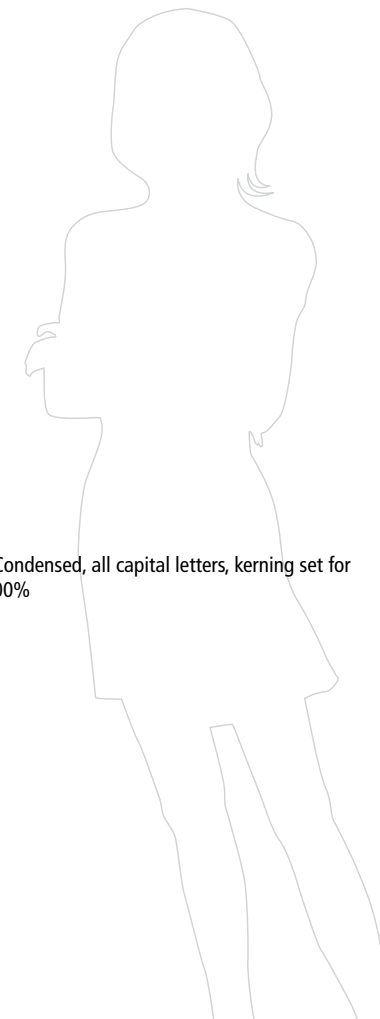

**D-1 MAIN DIRECTORY, FREESTANDING, w/HANDHELD MAP DETAIL**  
Scale: 1"=1'-0" on an 11" x 17" sheet



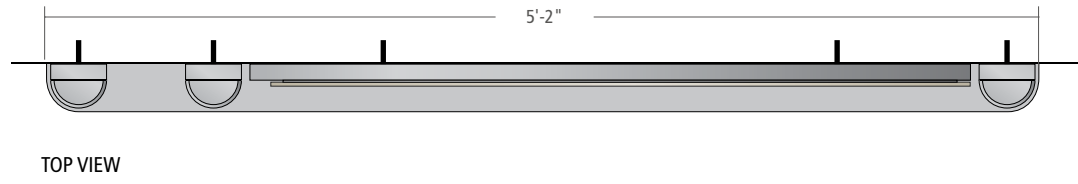

Custom fabricated cabinet with painted custom radius aluminum support poles.

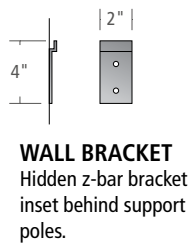
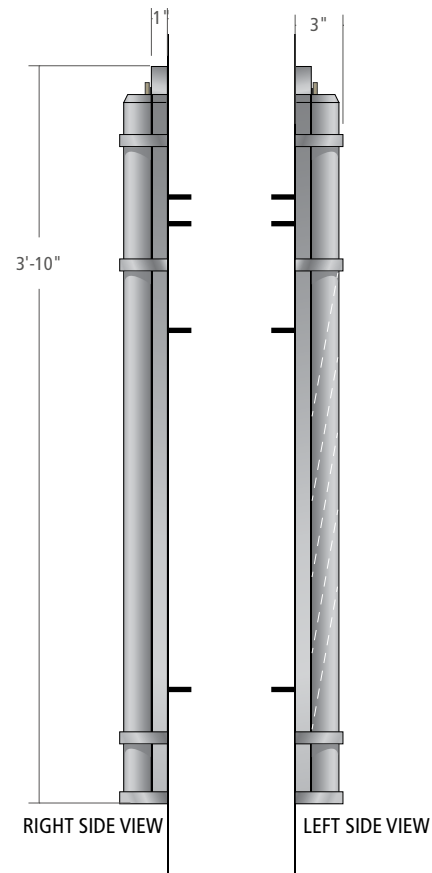

**WALL BRACKET**  
Hidden z-bar bracket inset behind support poles.

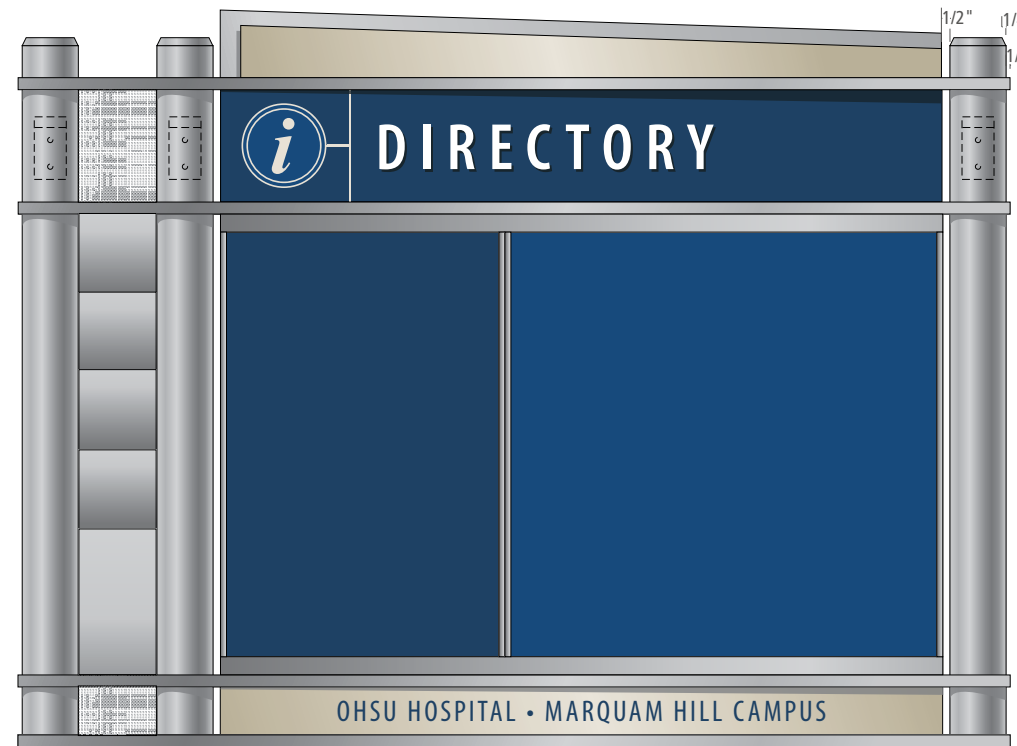

**DECORATIVE HEADER**

Custom fabricated cabinet with painted acrylic panels. Acrylic panels are mounted 1/8" off cabinet. 1/8" spacer should not be visible.

**DIRECTORY HEADER**

Custom fabricated cabinet with a silk-screened header. Header should surface align with with angled metallic silver decorative header above.

**ACCENT BARS**

3/4" (th.) painted aluminum accent bars welded to support poles.

**DIRECTORY CABINET**

APCO FullView Large Assembly sign - horizontal configuration with vertical divider bar. Mounted to backer plate, signs should be flush with Header above. Large format printed inserts sit behind matte acrylic lens. Inserts should fit tight against acrylic window for optimal appearance. Window is removed from frame with a suction cup tool using a lift/pull technique. 3'-9" w x 2'-5" h

**DECORATIVE FOOTER**

Custom fabricated cabinet with painted acrylic panels. Panels should align with insert windows above.

**INSTALLATION**

Sign to be mechanically fastened to wall. Depending on wall condition extra backing may be required to support weight of sign. Recommend using z-bar clips inset behind support poles and mechanical fasteners through APCO FullView Large mounting plate.

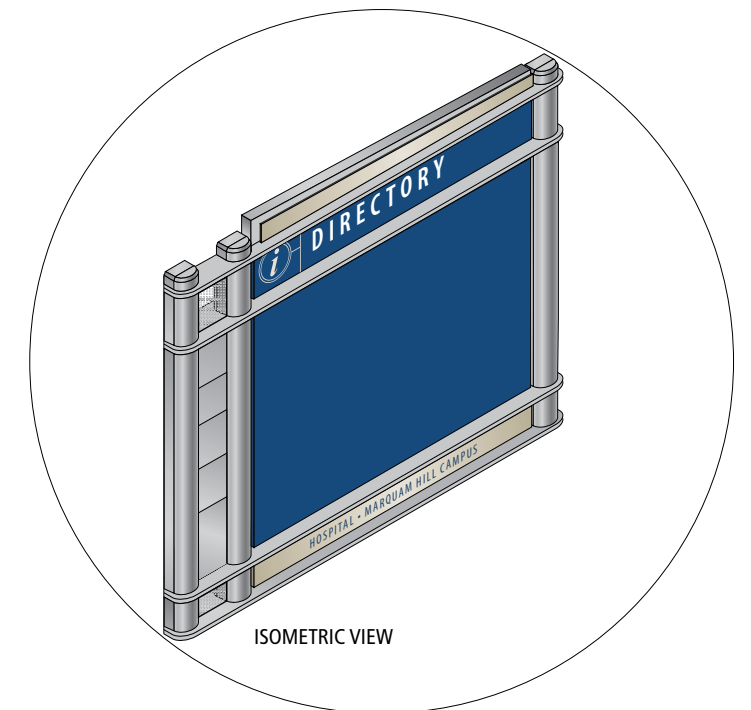

**HANDHELD MAP HOLDER**  
Custom fabricated cabinet with angled slots to hold folded vertical 8.5" x 11" brochure inserts. Fabricator to engineer insert slots and quantity. Background of cabinet is a painted mesh screen.

**D-1a MAIN DIRECTORY, WALL MOUNTED, w/HANDHELD MAP**  
Scale: 1" = 1'-0" on an 11" x 17" sheet

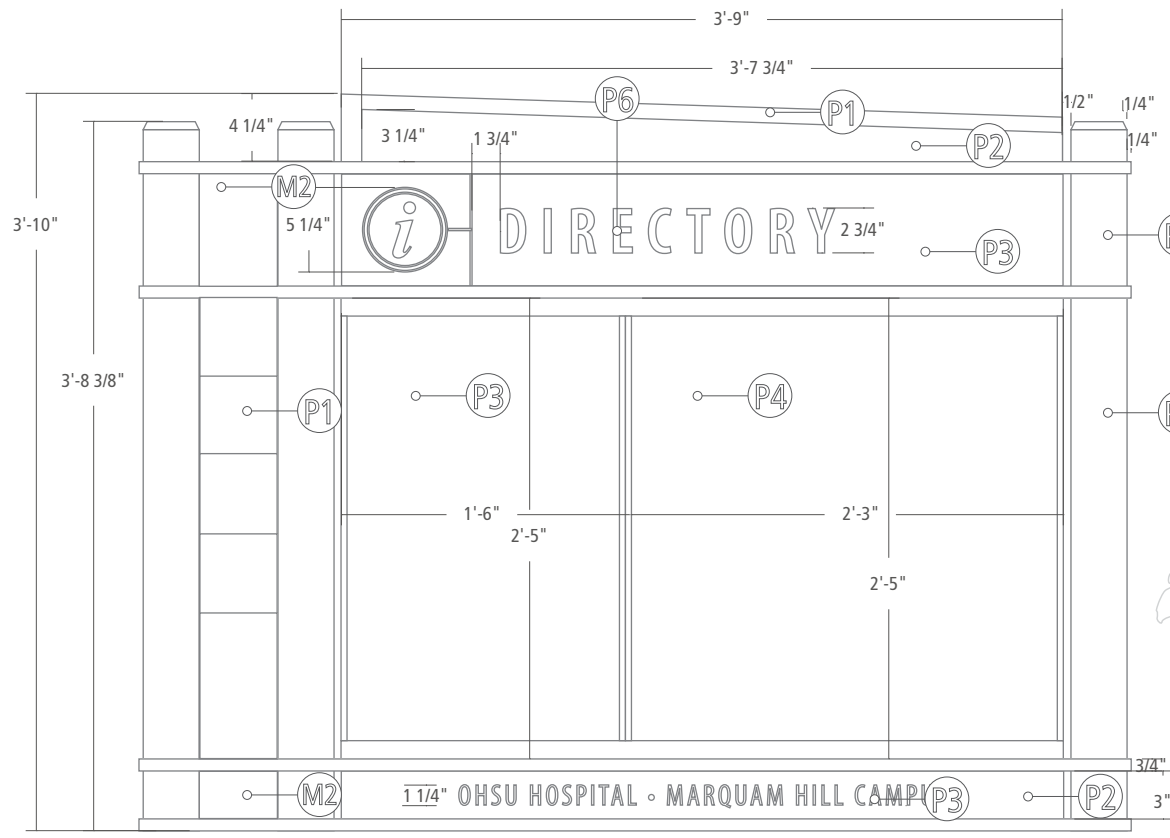
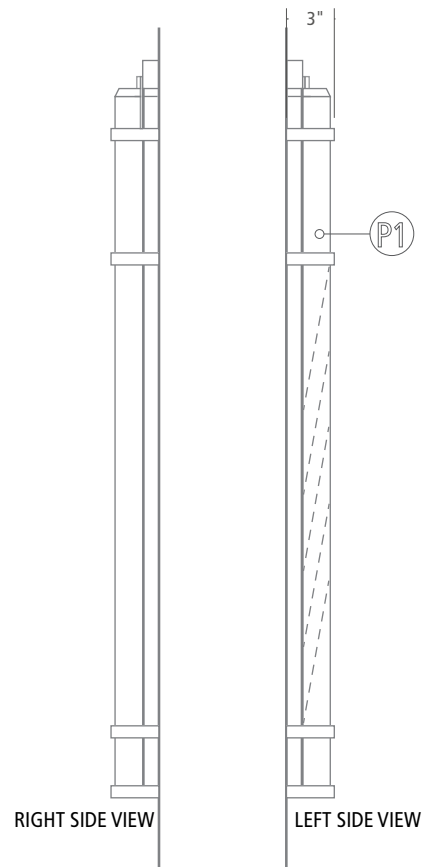
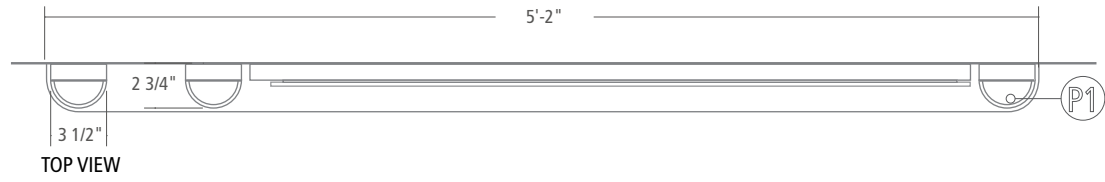

**DIRECTORY**  
Myriad Pro Semibold Condensed, kerning set for Optical at 200%

**FOOTER**  
Myriad Pro Condensed, all capital letters, kerning set for Optical at 100%

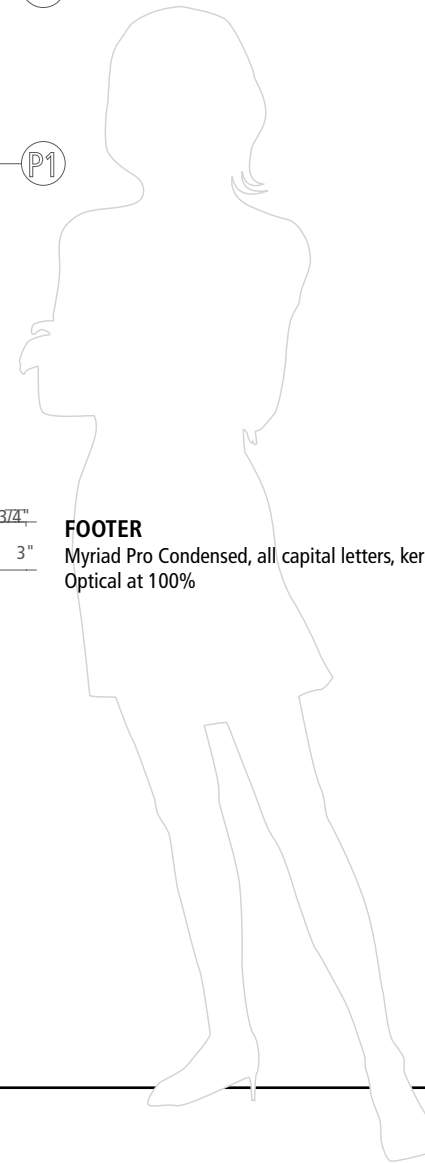

**D-1a MAIN DIRECTORY, WALL MOUNTED, w/HANDHELD MAP**  
Scale: 1"=1'-0" on an 11" x 17" sheet

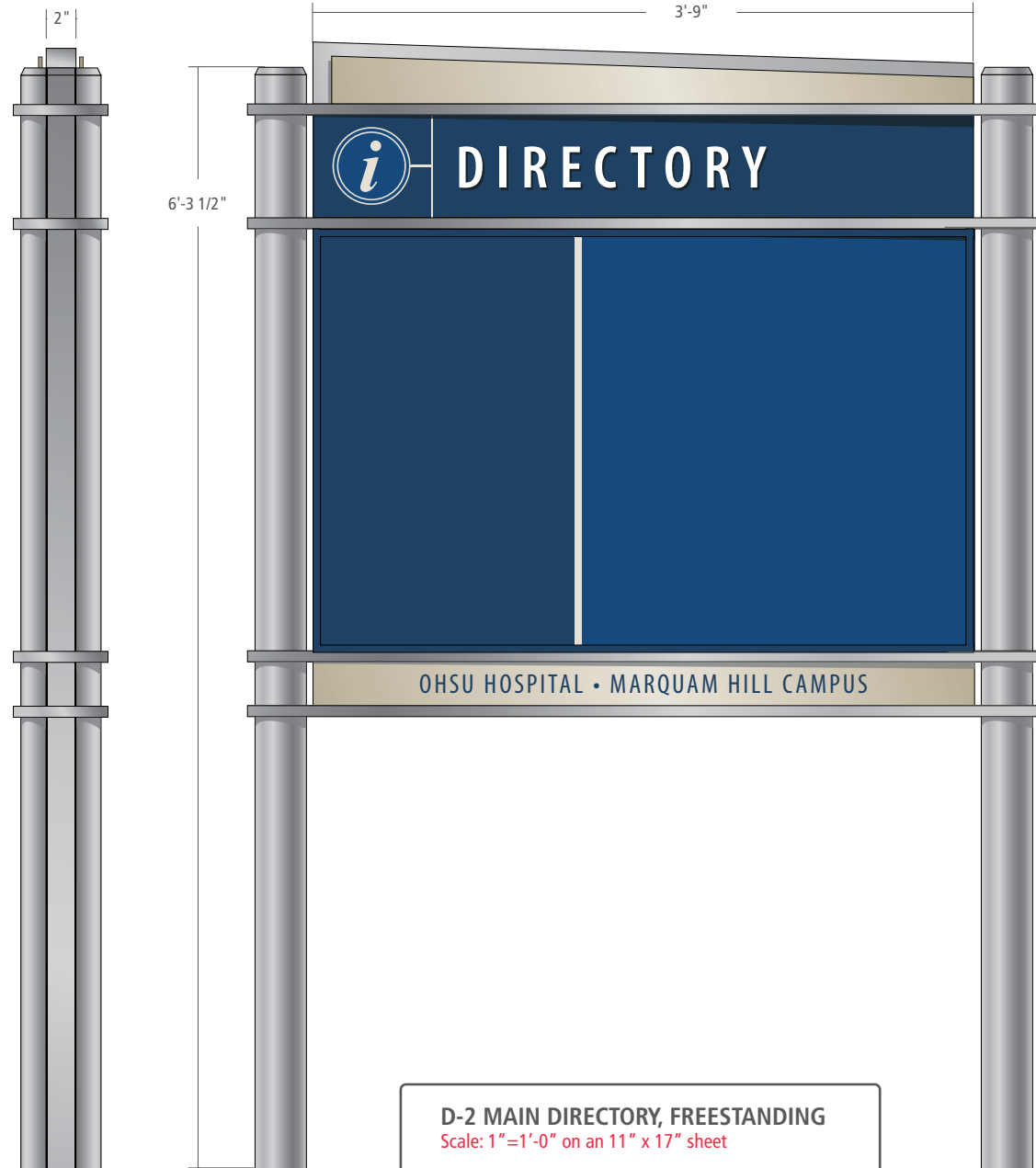
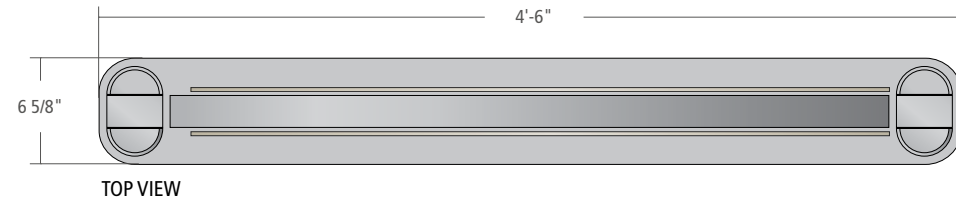

**D-2 MAIN DIRECTORY, FREE STANDING**  
 Custom fabricated cabinet with painted aluminum poles. Decorative angled fins painted silver metallic and champagne metallic. Header is painted with 1/4" thick acrylic white letters. Footer is an insert behind an acrylic window. Map and destination listings are contained within a cabinet with two acrylic window faces. Acrylic windows are removed by pushing up into reveals notched into the top of the cabinet. Physician directory has only one acrylic window.

**SPECIFICATIONS**  
 See D-1 Main Directory for additional fabrication specifications.

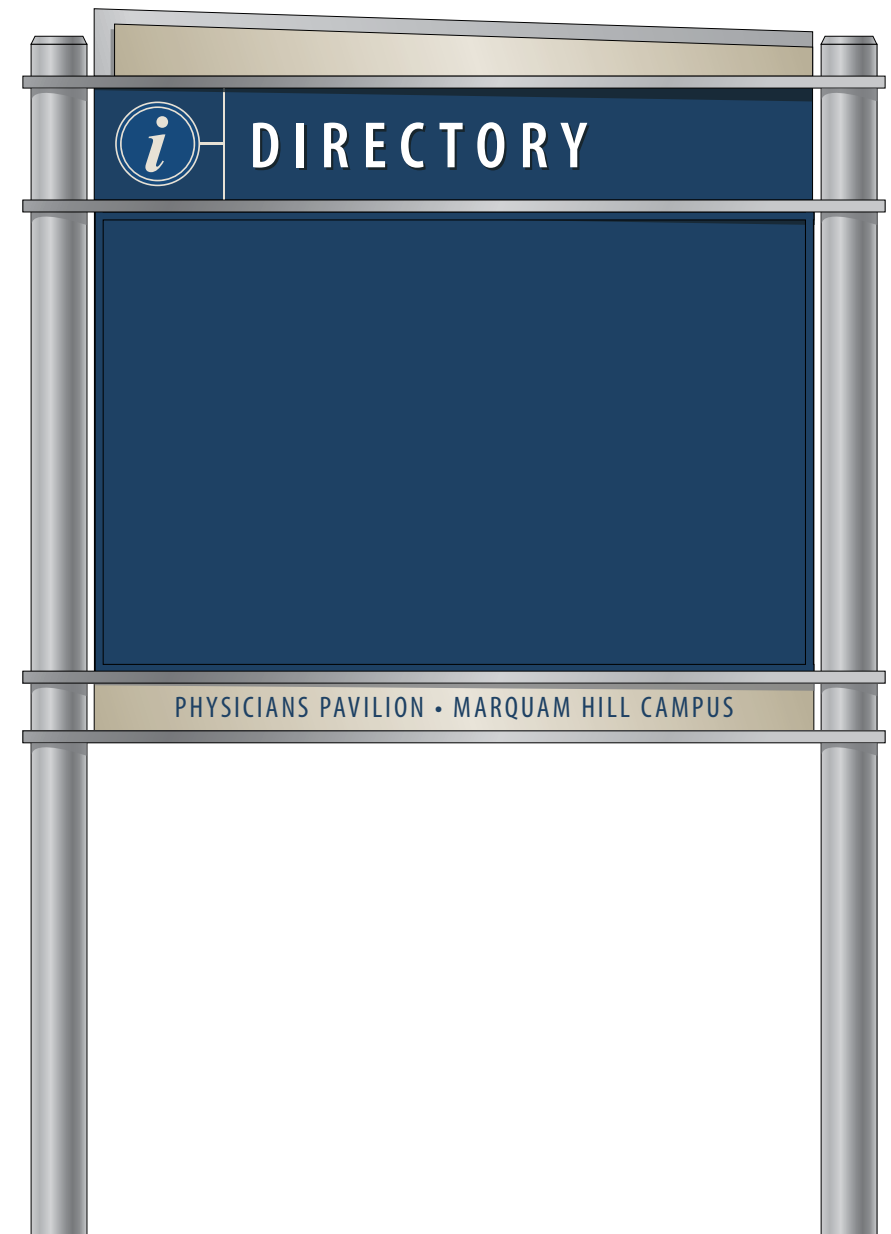
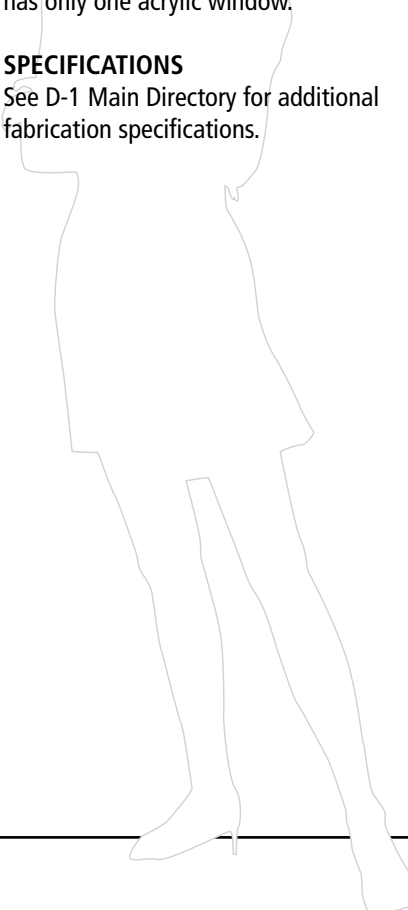

**D-2 MAIN DIRECTORY, FREESTANDING**  
 Scale: 1"=1'-0" on an 11" x 17" sheet

SIDE VIEW

SIDE VIEW

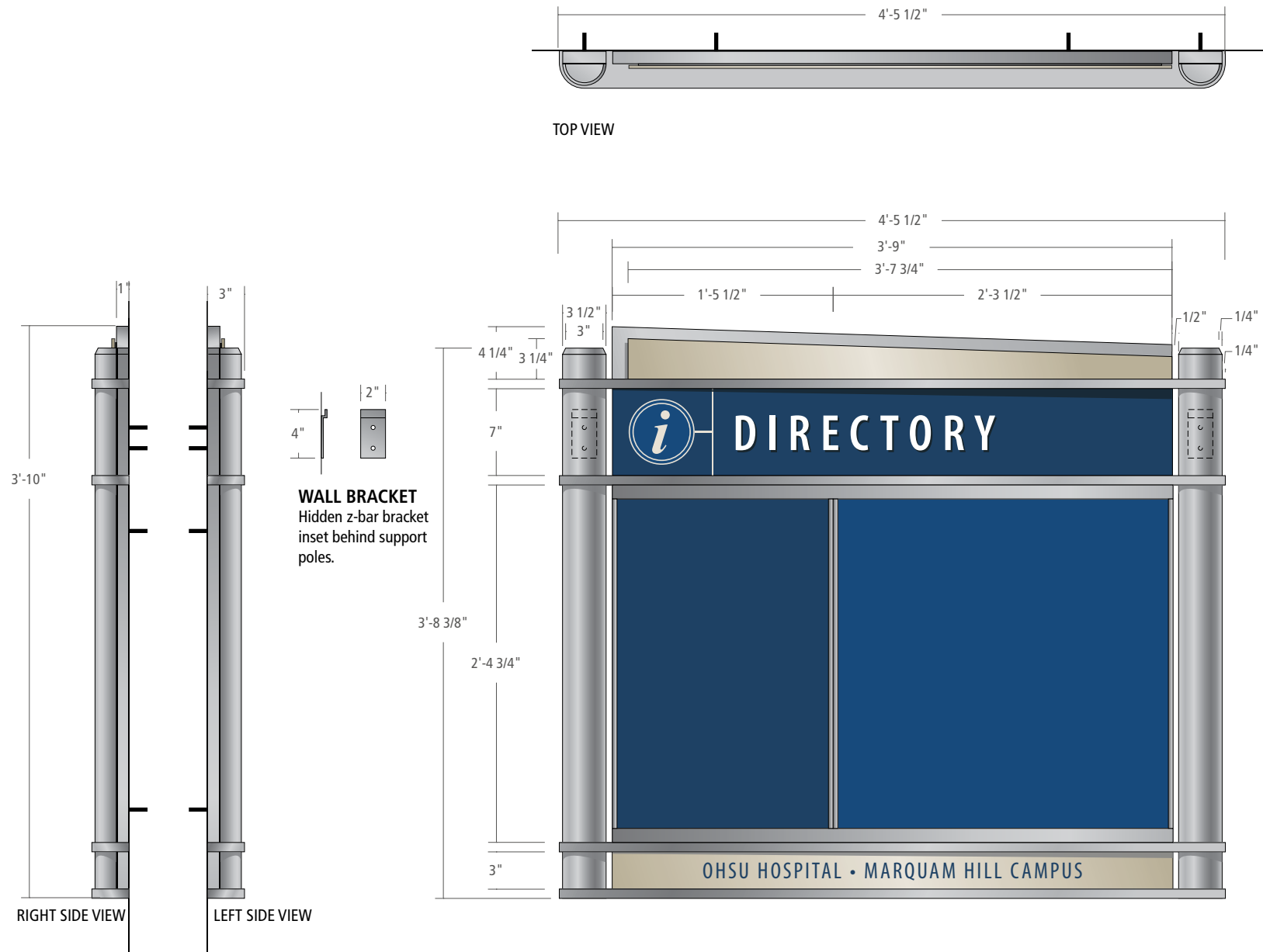

Custom fabricated cabinet with painted custom radius aluminum support poles.

**DECORATIVE HEADER**

Custom fabricated cabinet with painted acrylic panels. Acrylic panels are mounted 1/8" off cabinet. 1/8" spacer should not be visible.

**DIRECTORY HEADER**

Custom fabricated cabinet with a silk-screened header. Header should surface align with with angled metallic silver decorative header above.

**ACCENT BARS**

3/4" (th.) painted aluminum accent bars welded to support poles.

**DIRECTORY CABINET**

APCO FullView Large Assembly sign - horizontal configuration with vertical divider bar. Mounted to backer plate, signs should be flush with Header above. Large format printed inserts sit behind matte acrylic lens. Inserts should fit tight against acrylic window for optimal appearance. Window is removed from frame with a suction cup tool using a lift/pull technique. 3'-9"w x 2'-5"h

Non-illuminated inserts will minimally be printed at 1200 DPI using pigment-based UV inks on a white, satin finish UV-coated photo paper, with a matte UV over-laminate (unless otherwise noted in the design intent drawings). The thickness of the photo paper must be heavy enough such that no wrinkles or waves will occur once installed into the sign housings. If necessary, rigid backers may be used.

**DECORATIVE FOOTER**

Custom fabricated cabinet with painted acrylic panels. Panels should align with insert windows above.

**INSTALLATION**

Sign to be mechanically fastened to wall. Depending on wall condition extra backing may be required to support weight of sign. Recommend using z-bar clips inset behind support poles and mechanical fasteners through APCO FullView Large mounting plate.

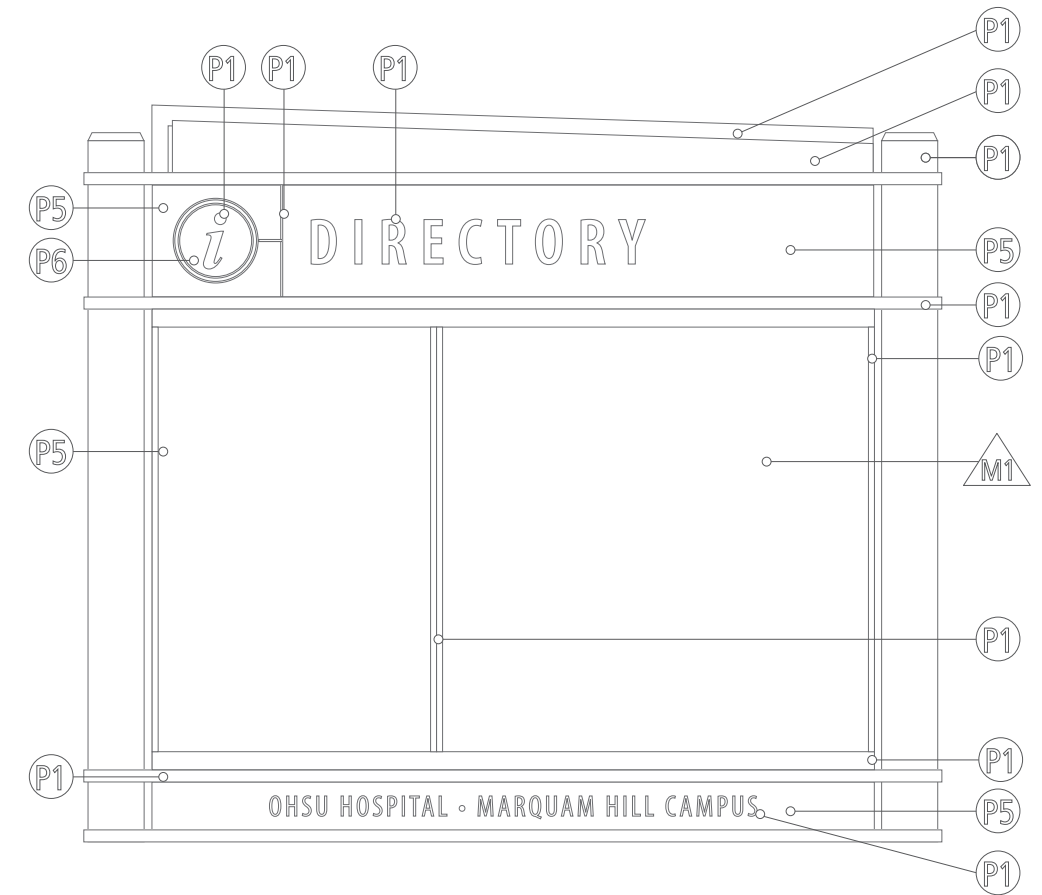

**D-2a MAIN DIRECTORY, WALL MOUNTED**  
 Scale: 1"=1'-0" on an 11" x 17" sheet

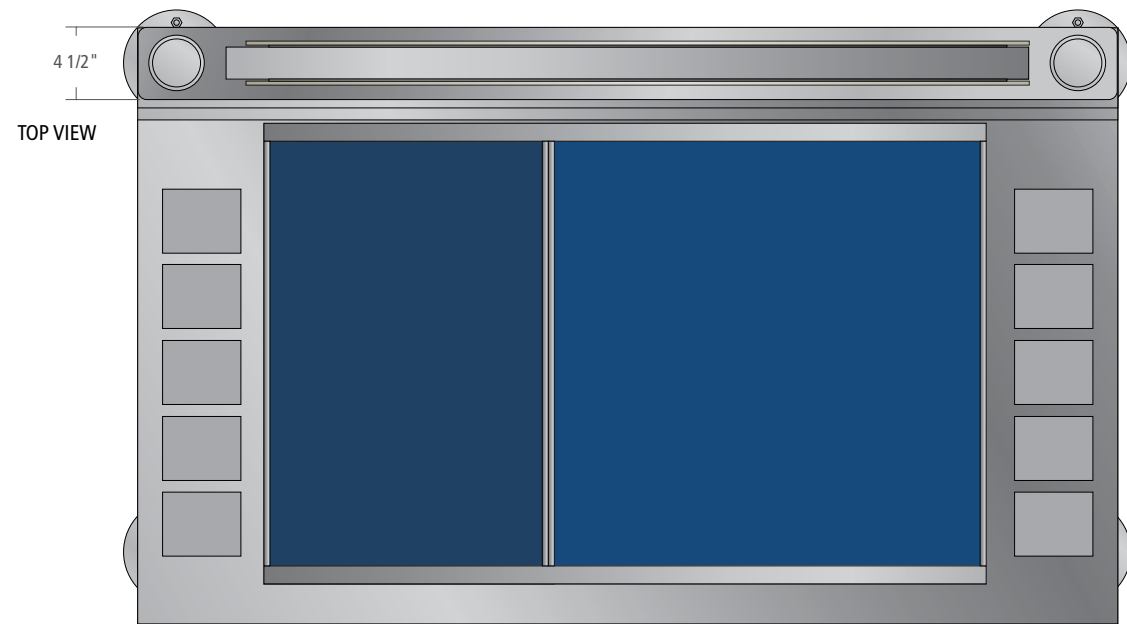

Custom cabinet fabricated out of 1/8" (th.) painted aluminum with painted 3 1/2" round support poles with beveled top edges.

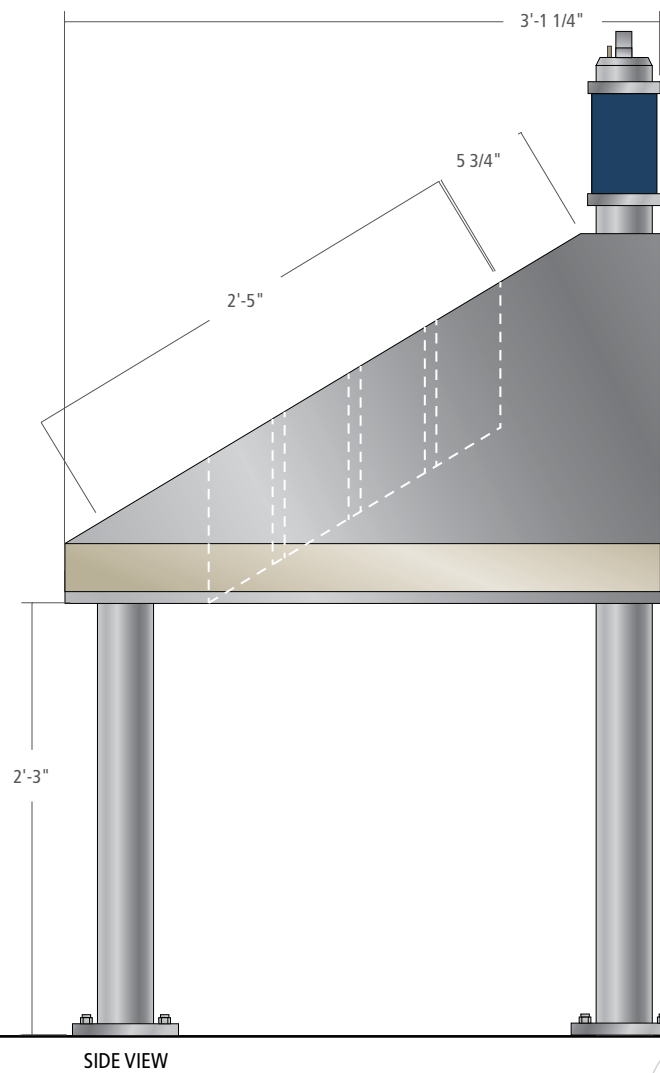

**HANDHELD MAP HOLDERS**  
 Custom fabricated cabinet with angled slots (flush to the surface of the cabinet) to hold folded vertical 8.5" x 11" brochure inserts. Fabricator to engineer insert slots and quantity.

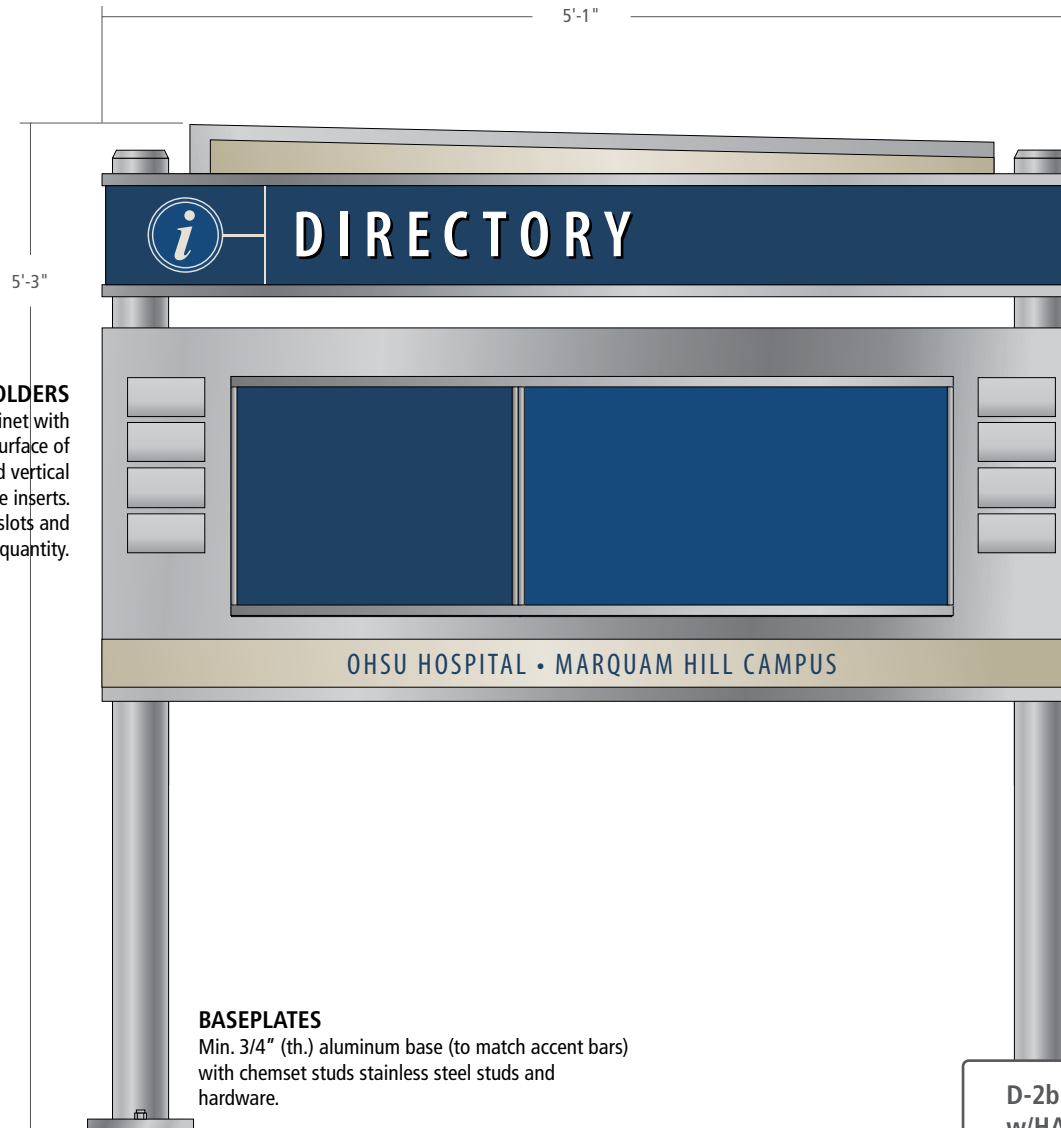

**BASEPLATES**  
 Min. 3/4" (th.) aluminum base (to match accent bars) with chemset studs stainless steel studs and hardware.

**DECORATIVE HEADER**

Custom fabricated cabinet with painted acrylic panels. Acrylic panels are mounted 1/8" off cabinet. 1/8" spacer should not be visible.

**DIRECTORY HEADER**

Header fabricated out of 1/8" (th.) aluminum silk-screened (or mask and spray) copy and graphics.

**DIRECTORY CABINET**

APCO FullView Large Assembly sign - horizontal configuration with vertical divider bar. Inset flush to the surface of the sign. Large format printed inserts sit behind matte acrylic lens. Inserts should fit tight against acrylic window for optimal appearance. Window is removed from frame with a suction cup tool using a lift/pull technique. Units are the same size as the D-1 and D-1a 3'-9"w x 2'-5"h

**DECORATIVE FOOTER**

Silk-screened footer and graphics.

**D-2b MAIN DIRECTORY, FREESTANDING, ANGLED, w/HANDHELD MAP**  
 Scale: 1"=1'-0" on an 11" x 17" sheet



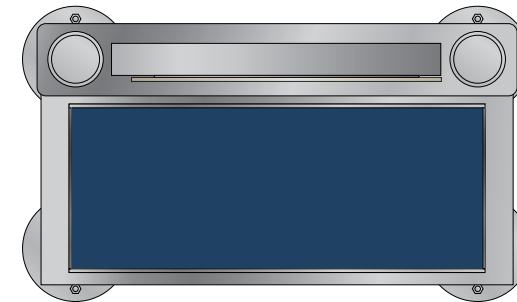

Top VIEW

Custom cabinet fabricated out of 1/8" (th.) painted aluminum with painted 3 1/2" round support poles with beveled top edges.

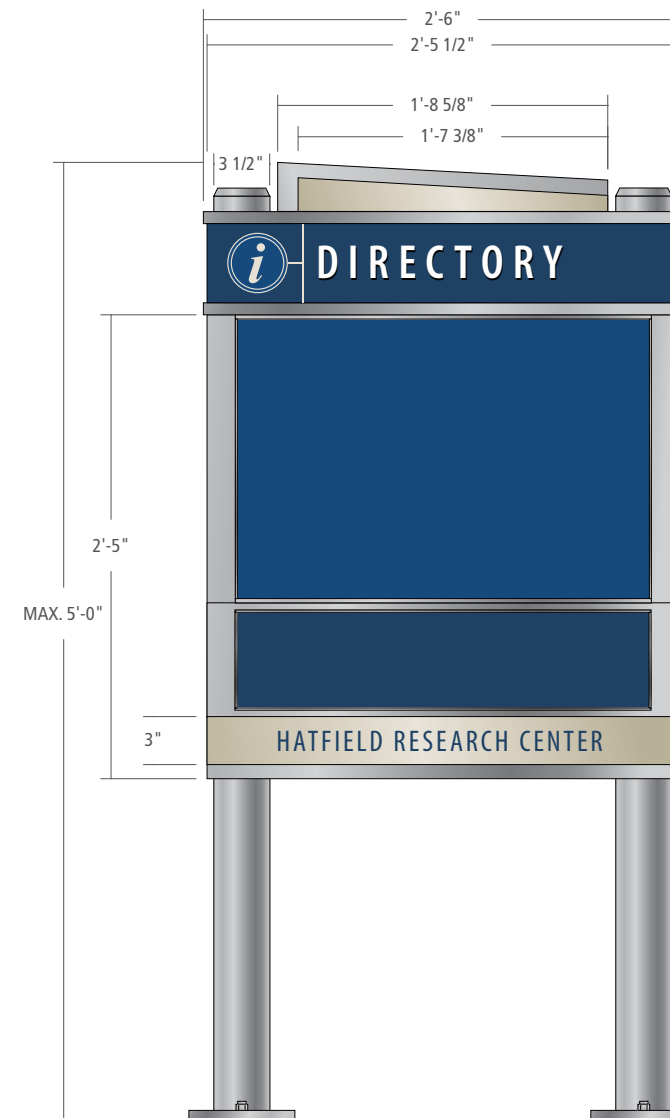
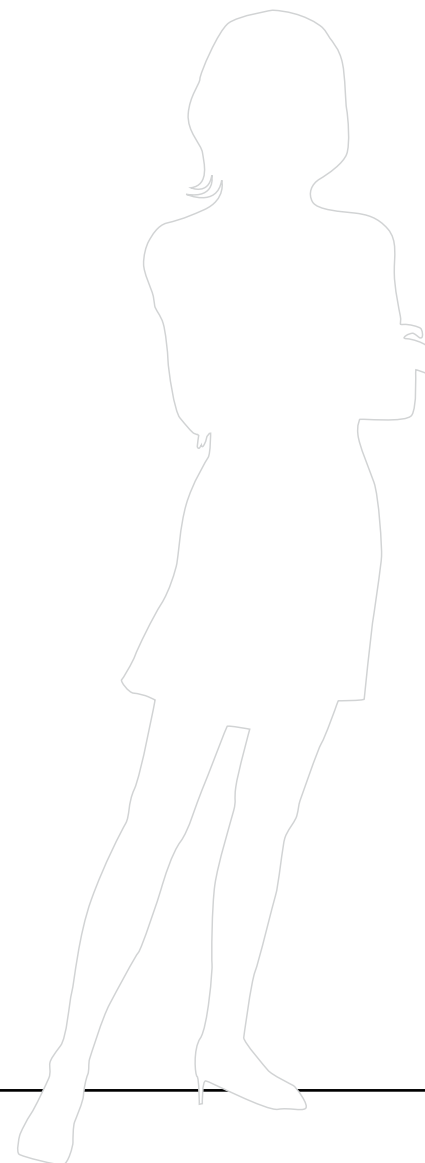
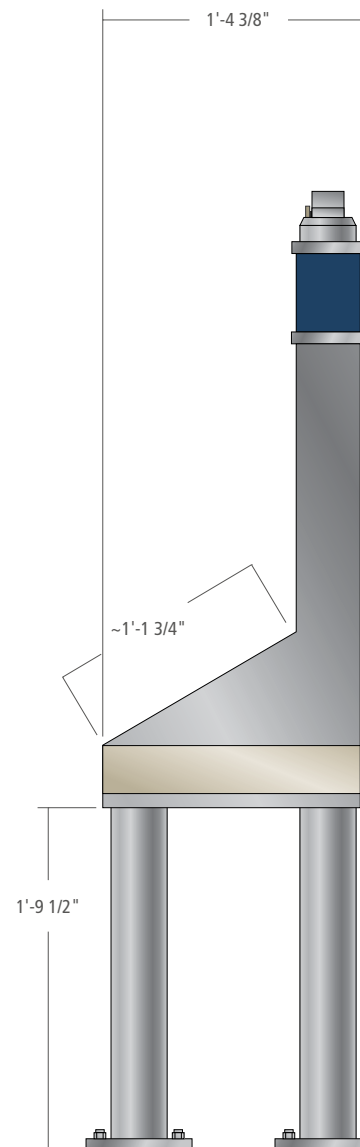

**DECORATIVE HEADER**

Custom fabricated cabinet with painted acrylic panels. Acrylic panels are mounted 1/8" off cabinet. 1/8" spacer should not be visible.

**DIRECTORY HEADER**

Header fabricated out of 1/8" (th.) aluminum silk-screened (or mask and spray) copy and graphics.

**DIRECTORY CABINET UPPER UNIT**

APCO FullView Standard Assembly signs - horizontal configuration, mounted in a painted aluminum cabinet, flush with surface. Large format printed inserts sit behind matte acrylic lens. Inserts should fit tight against acrylic window for optimal appearance. Window is removed from frame with a suction cup tool using a lift/pull technique. FVS1826(H)

**DIRECTORY CABINET LOWER UNIT**

Similar construction to upper unit FVS1226(H)

**DECORATIVE FOOTER**

Silk-screened footer and graphics.

**SUPPORT POLES**

3 1/2" round support poles with beveled top edges.

**BASEPLATES**

Min. 3/4" (th.) aluminum base (to match accent bars) with chemset studs stainless steel studs and hardware.

**D-2d MAIN DIRECTORY, FREESTANDING, TALL-ANGLED**  
Scale: 1" = 1'-0" on an 11" x 17" sheet

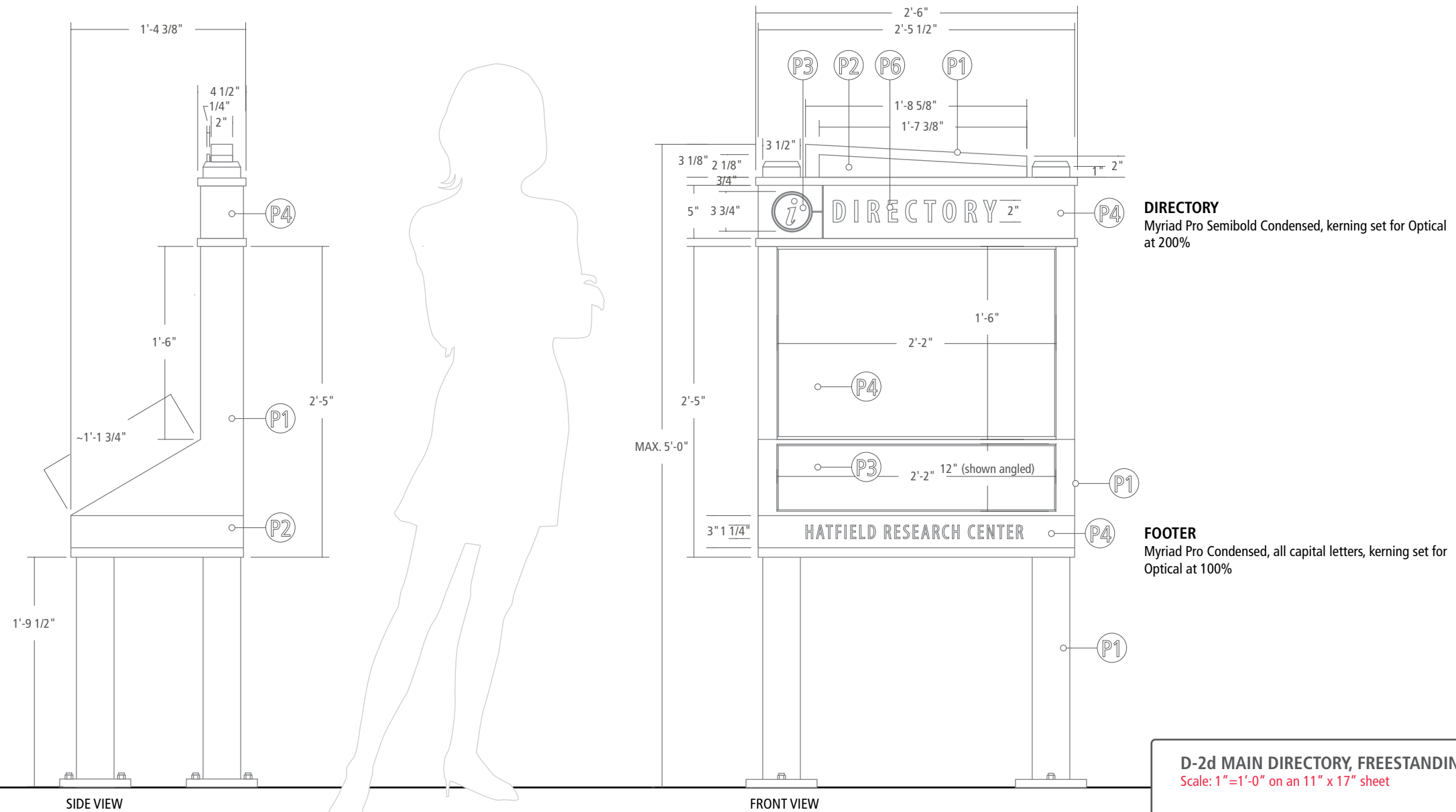



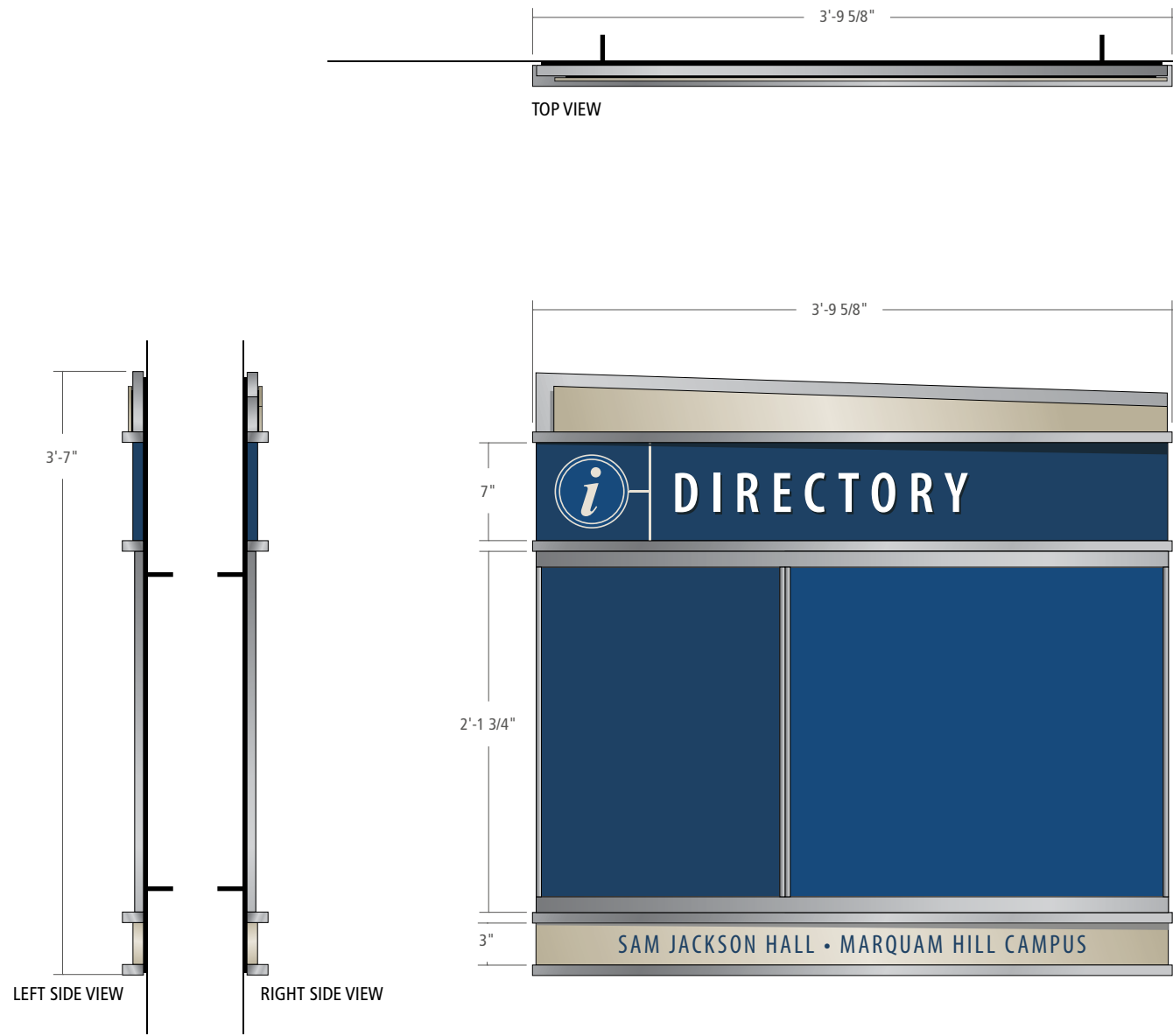

Custom fabricated cabinet, see details below.

**DECORATIVE HEADER**

Custom fabricated cabinet with painted acrylic panels. Acrylic panels are mounted 1/8" off cabinet. 1/8" spacer should not be visible.

**DIRECTORY HEADER**

3/4" (th.) painted acrylic header with silk-screened copy and graphics. Edges painted to match face. VHB taped to backer plate.

**ACCENT BARS**

3/4" (th.) painted aluminum accent bars mechanically fastened to backer plate.

**DIRECTORY CABINET**

APCO FullView Large Assembly sign - horizontal configuration with vertical divider bar. Mounted to backer plate, signs should be flush with Header above. Large format printed inserts sit behind matte acrylic lens. Inserts should fit tight against acrylic window for optimal appearance. Window is removed from frame with a suction cup tool using a lift/pull technique. 3'-9" w x 2'-13/4" h

**DECORATIVE FOOTER**

3/4" (th.) painted acrylic header with silk-screened copy and graphics. Edges painted to match face. VHB taped to backer plate.

**INSTALLATION**

Sign to be mechanically fastened to wall through APCO FullView Large mounting plate. Depending on wall condition extra backing may be required to support weight of sign.

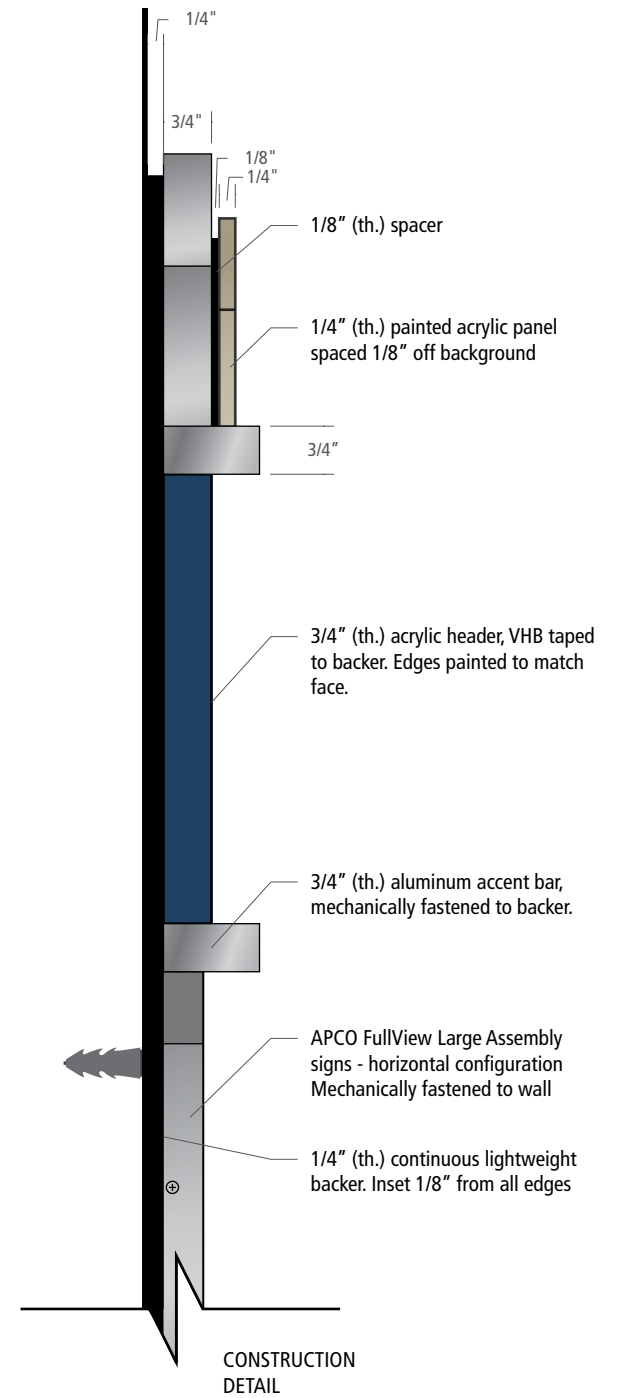

**D-2c MAIN DIRECTORY, WALL MOUNTED, SIMPLIFIED**  
Scale: 1" = 1'-0" on an 11" x 17" sheet

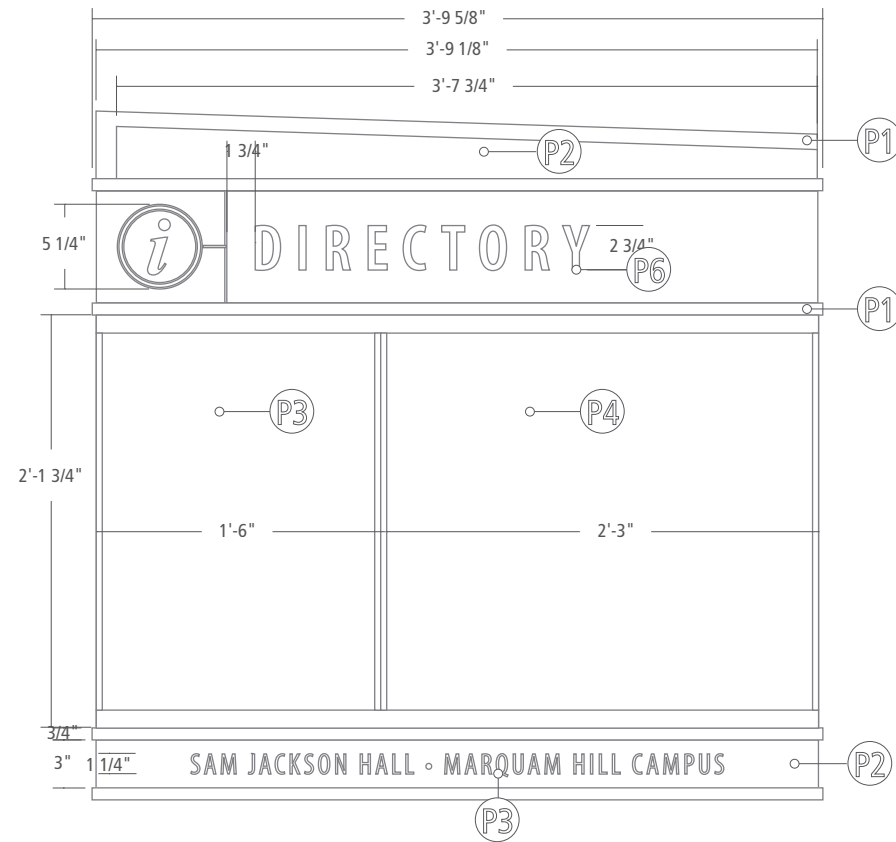
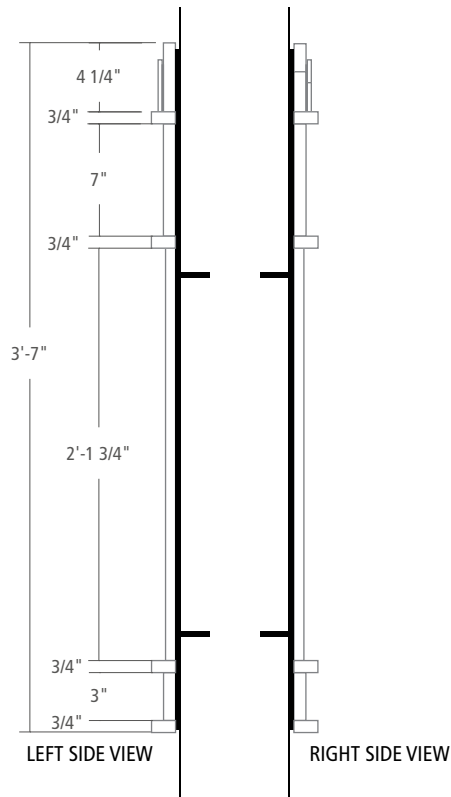
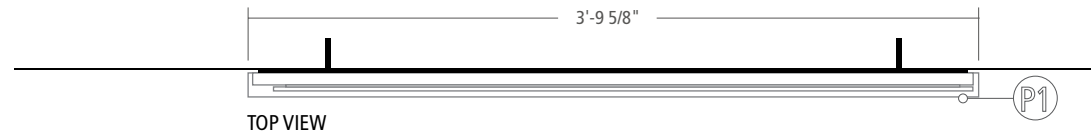

**DIRECTORY**  
Myriad Pro Semibold Condensed, kerning set for Optical at 200%

**FOOTER**  
Myriad Pro Condensed, all capital letters, kerning set for Optical at 100%

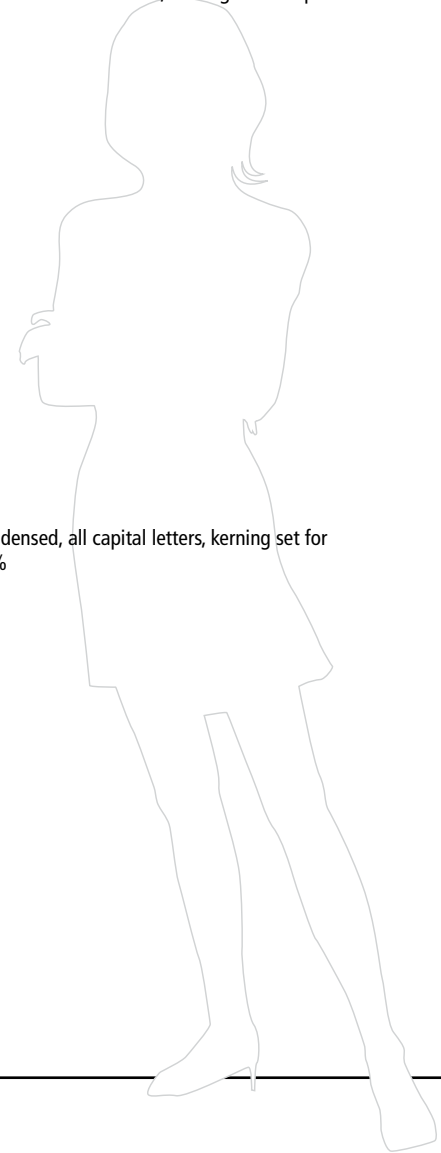

**D-2c MAIN DIRECTORY, WALL MOUNTED, SIMPLIFIED DETAIL**  
Scale: 1" = 1'-0" on an 11" x 17" sheet



**D-2f MAIN DIRECTORY, WALL MOUNTED, SIMPLIFIED**  
Scale: 1"=1'-0" on an 11" x 17" sheet

LAYOUT EXAMPLES

**PHYSICIANS PAVILION ELEVATOR**  
Floor 1

**SAM JACKSON ELEVATOR**  
Floor 1

**DOERNBECHER ELEVATOR**  
Floor 3

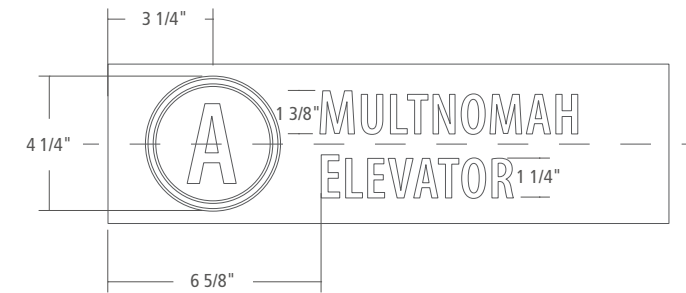

**HEADER FONT:**  
Myriad Pro Semibold  
Condensed @ 25%  
kerning. Set for Optical  
kerning. Text is in all  
capital letters.



**FOOTER FONT:**  
Myriad Pro Condensed  
@ 25% kerning. Set for  
Optical kerning.

HEADER AND FOOTER DETAILS  
Scale: 2"=1'-0" on an 11" x 17" sheet

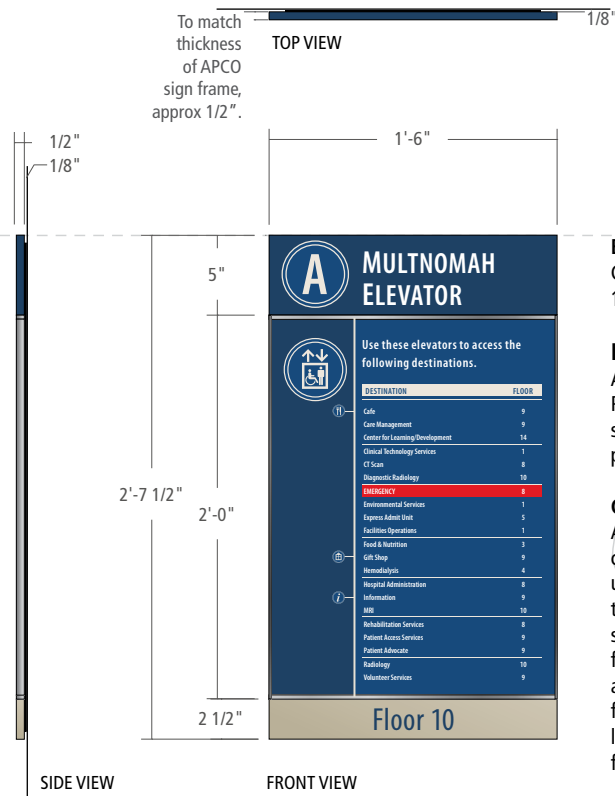

**BACKER PLATE:**  
Constructed from  
1/8" (th.) acrylic, inset 1/4" from edges

**HEADER:**  
Acrylic panel with silk-screened graphics.  
Panel thickness to equal thickness of APCO  
sign frame. Panel is mounted to backer  
panel.

**CABINET:**  
APCO FullView FVS2418(H)MF - horizontal  
configuration, pin to be installed in the  
upper left position (with no pin), mounted  
to acrylic panel. Large format printed insert  
sits behind matte acrylic lens. Insert should  
fit tight against acrylic window for optimal  
appearance. Window is removed from  
frame with a suction cup tool using a  
lift/pull technique. Cabinet to be surface  
flush with decorative header above.

**FOOTER:**  
Acrylic panel with silk-screened graphics.  
Panel thickness to equal thickness of APCO  
sign frame. Panel is mounted to backer  
panel.

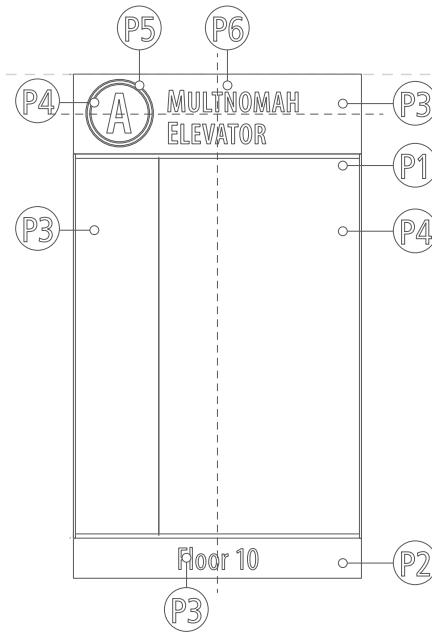

**D-3a ELEVATOR DIRECTORY**  
Scale: 1"=1'-0" on an 11" x 17" sheet

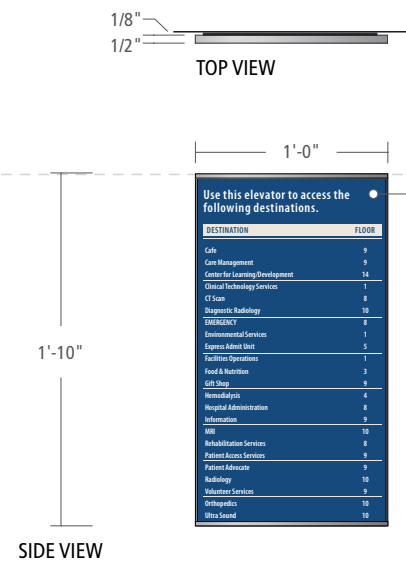

**D-3b ELEVATOR DIRECTORY, INSIDE CAB**

Scale: 1"=1'-0" on an 11" x 17" sheet

**BACKER PLATE:** Constructed from 1/8" (th.) acrylic, inset 1/4" from edges.

**SIGN FRAME:** APCO FullView FVS2212(H)MF - horizontal configuration, pin to be installed in the upper left position (with no pin), mounted to acrylic panel. Large format printed insert sits behind matte acrylic lens. Insert should fit tight against acrylic window for optimal appearance. Window is removed from frame with a suction cup tool using a lift/pull technique.

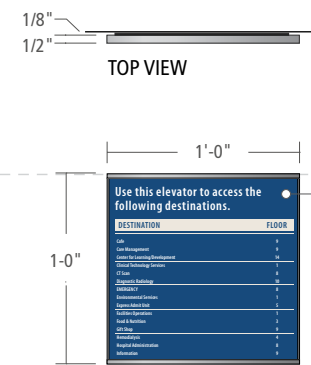

**D-3c ELEVATOR DIRECTORY, INSIDE CAB**

Scale: 1"=1'-0" on an 11" x 17" sheet

**BACKER PLATE:** Constructed from 1/8" (th.) acrylic, inset 1/4" from edges.

**SIGN FRAME:** APCO FullView FVS1212(H)MF - horizontal configuration, pin to be installed in the upper left position (with no pin), mounted to acrylic panel. Large format printed insert sits behind matte acrylic lens. Insert should fit tight against acrylic window for optimal appearance. Window is removed from frame with a suction cup tool using a lift/pull technique.

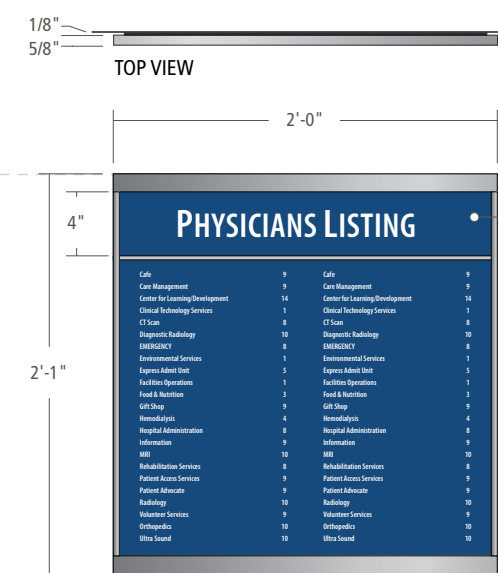

**D-3e PHYSICIAN DIRECTORY**

Scale: 1"=1'-0" on an 11" x 17" sheet

**BACKER PLATE:** Constructed from 1/8" (th.) acrylic, inset 1/4" from edges.

**SIGN FRAME:** APCO FullView FVL2524(H)MF - horizontal configuration, pin to be installed in the upper left position (with no pin), mounted to acrylic panel. Large format printed insert sits behind matte acrylic lens. Insert should fit tight against acrylic window for optimal appearance. Window is removed from frame with a suction cup tool using a lift/pull technique.



**D-3b ELEVATOR DIRECTORY, INSIDE CAB, DETAIL**  
Scale: 1"=1'-0" on an 11" x 17" sheet

**D-3c ELEVATOR DIRECTORY, INSIDE CAB DETAIL**  
Scale: 1"=1'-0" on an 11" x 17" sheet

**D-3e PHYSICIAN DIRECTORY DETAIL**  
Scale: 1"=1'-0" on an 11" x 17" sheet

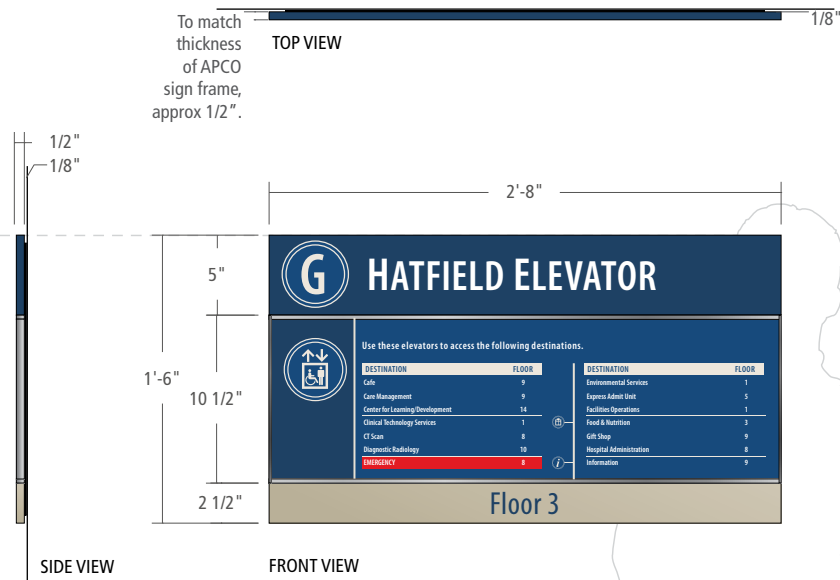

**BACKER PLATE:**  
Constructed from 1/8" (th.) acrylic, inset 1/4" from edges

**HEADER:**  
Acrylic panel with silk-screened graphics. Panel thickness to equal thickness of APCO sign frame. Panel is mounted to backer panel.

**CABINET:**  
Custom 32" x 10 1/2" APCO FullView sign frame with square edges - horizontal configuration, pin to be installed in the upper left position (with no pin), mounted to acrylic panel. Large format printed insert sits behind matte acrylic lens. Insert should fit tight against acrylic window for optimal appearance. Window is removed from frame with a suction cup tool using a lift/pull technique. Cabinet to be surface flush with decorative header above.

**FOOTER:**  
Acrylic panel with silk-screened graphics. Panel thickness to equal thickness of APCO sign frame. Panel is mounted to backer panel.

**D-3f CUSTOM ELEVATOR DIRECTORY**  
Scale: 1"=1'-0" on an 11" x 17" sheet

**APCO FULLVIEW**  
Large Assembly Sign - Horizontal Configuration

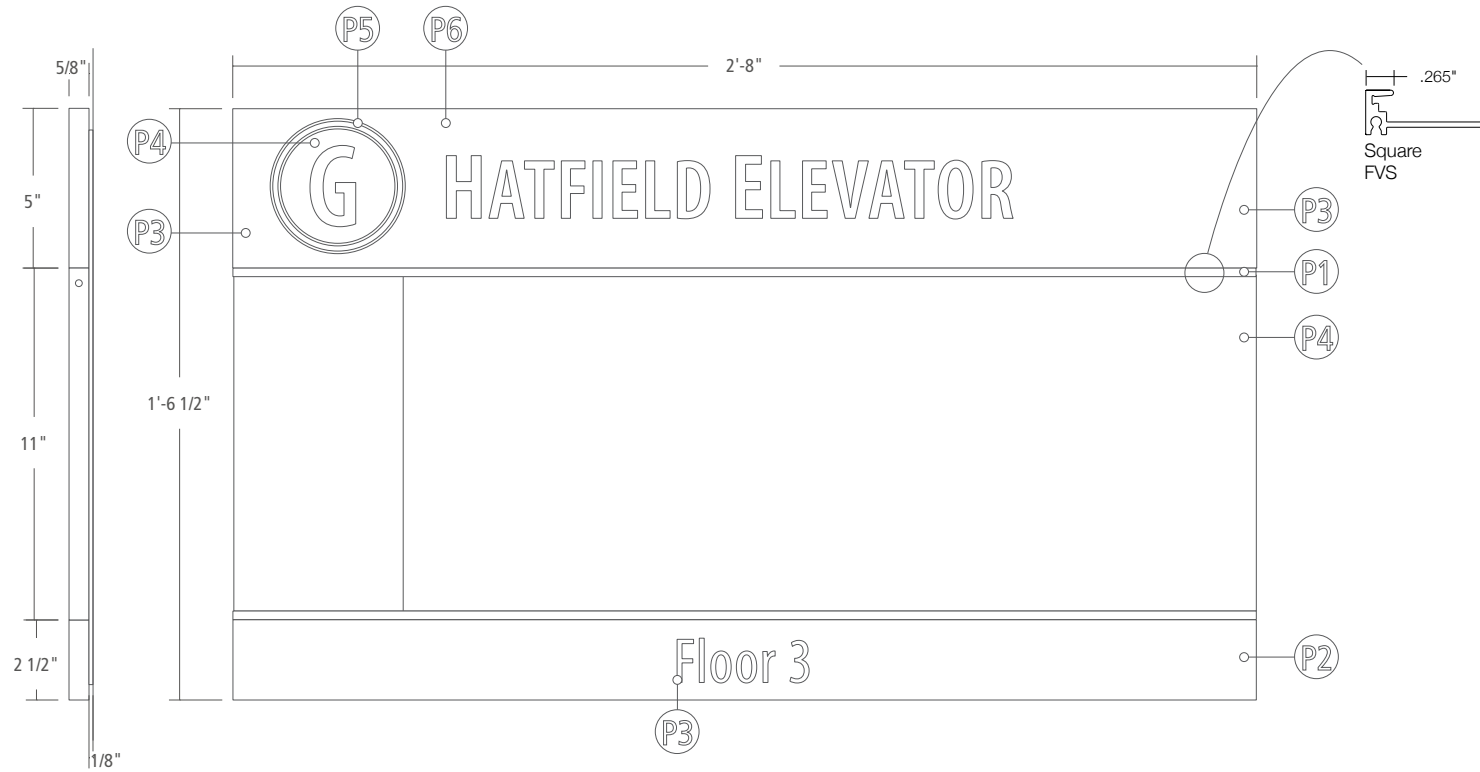

**HEADER FONT:**  
Myriad Pro Semibold  
Condensed @ 25%  
kerning. Set for Optical  
kerning. Text is in all  
capital letters.

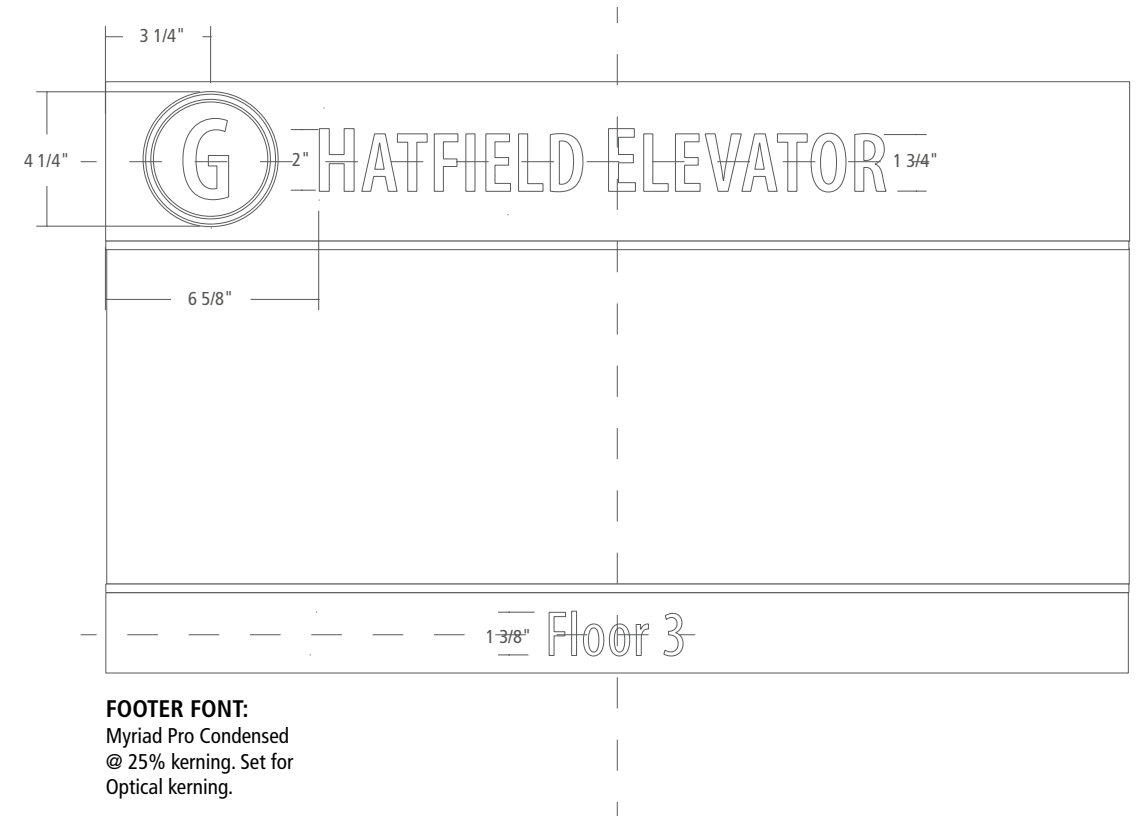

**FOOTER FONT:**  
Myriad Pro Condensed  
@ 25% kerning. Set for  
Optical kerning.

**D-3f CUSTOM ELEVATOR DIRECTORY DETAIL**  
SPECIFICATION DETAILS  
Scale: 2"=1'-0"



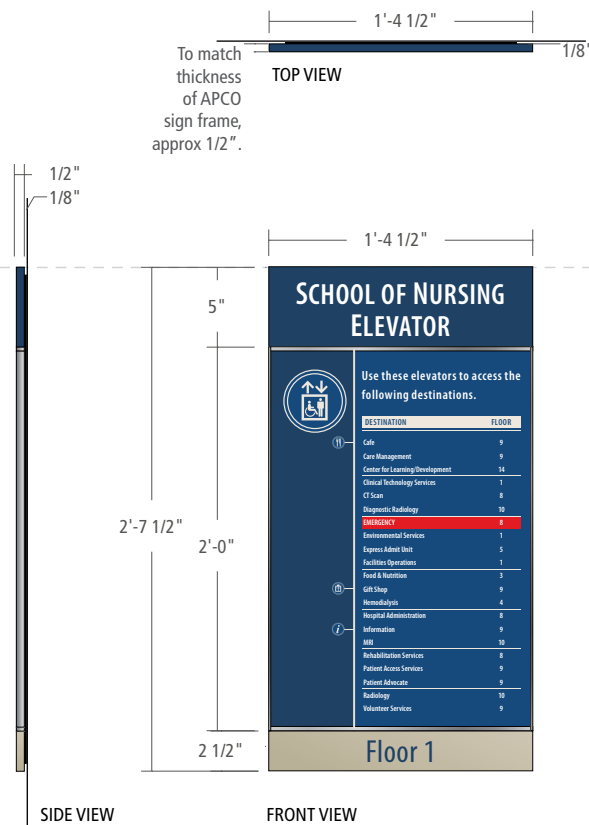

**BACKER PLATE:**  
Constructed from 1/8" (th.) acrylic, inset 1/4" from edges

**HEADER:**  
Acrylic panel with silk-screened graphics. Panel thickness to equal thickness of APCO sign frame. Panel is mounted to backer panel.

**CABINET:**  
APCO FullView FVS2416.5(H)MF - horizontal configuration, pin to be installed in the upper left position (with no pin), mounted to acrylic panel. Large format printed insert sits behind matte acrylic lens. Insert should fit tight against acrylic window for optimal appearance. Window is removed from frame with a suction cup tool using a lift/pull technique. Cabinet to be surface flush with decorative header above.

**FOOTER:**  
Acrylic panel with silk-screened graphics. Panel thickness to equal thickness of APCO sign frame. Panel is mounted to backer panel.

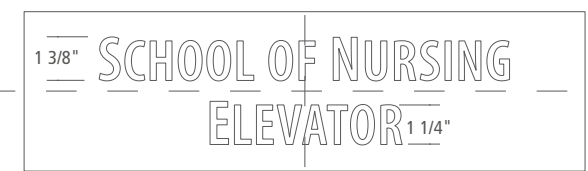
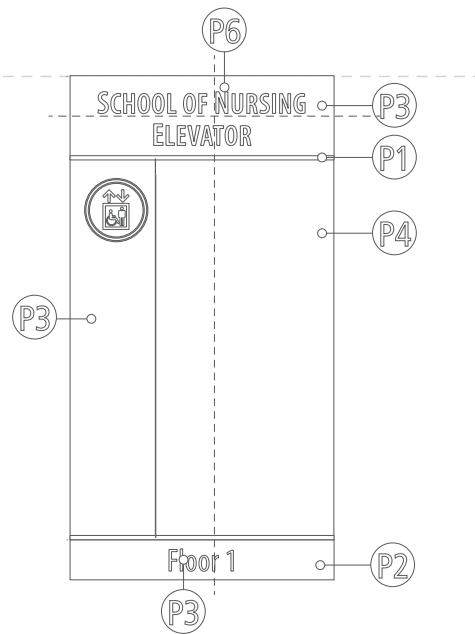

**HEADER FONT:**  
Myriad Pro Semibold Condensed @ 25% kerning. Set for Optical kerning. Text is in all capital letters.



**FOOTER FONT:**  
Myriad Pro Condensed @ 25% kerning. Set for Optical kerning.

**HEADER AND FOOTER DETAILS**  
Scale: 2"=1'-0" on an 11" x 17" sheet

**D-3g ELEVATOR DIRECTORY**  
Scale: 1"=1'-0" on an 11" x 17" sheet

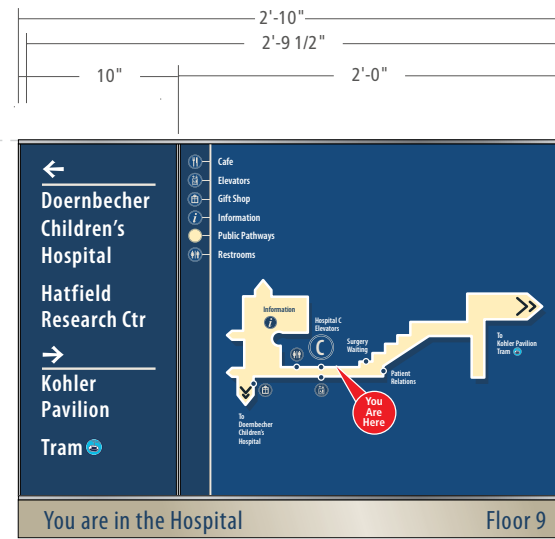
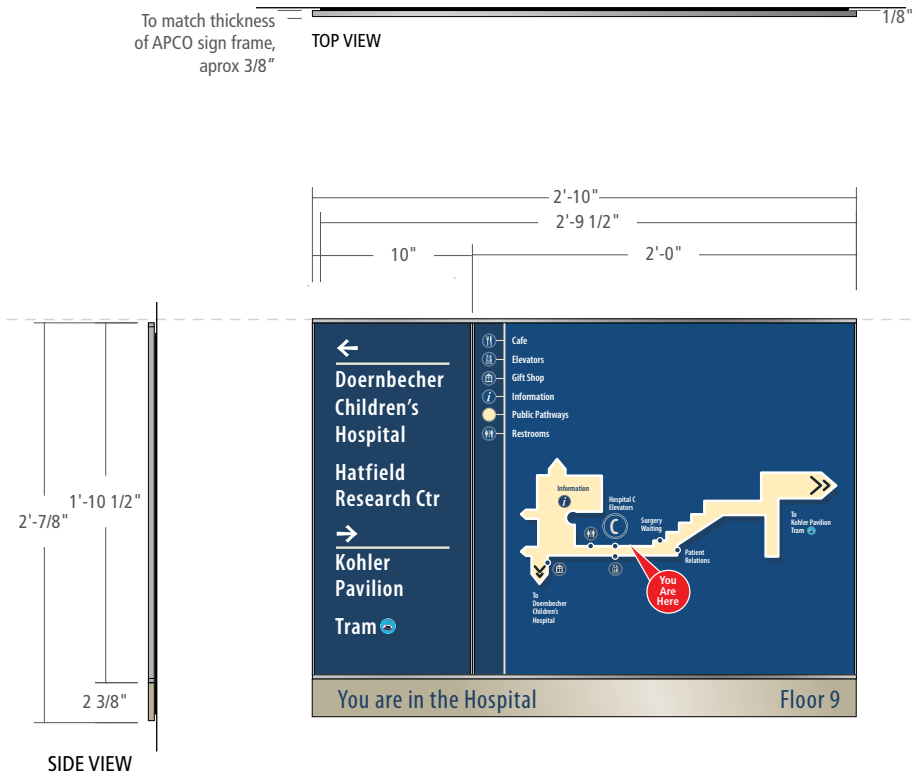

**BACKER PLATE:**

1/8" Acrylic panel mounted to the wall.

**SIGN FRAME:**

APCO FullView FVS2234(H)MF - horizontal configuration, pin to be installed in the upper left position (with no pin), mounted to acrylic panel. Large format printed insert sits behind matte acrylic lens. Insert should fit tight against acrylic window for optimal appearance. Window is removed from frame with a suction cup tool using a lift/pull technique. Cabinet to be surface flush with decorative header above.

**FOOTER:**

Acrylic panel with silk-screened graphics. Panel surface to be flush with decorative header and cabinet above.

See guide detail page for sections and specifications.

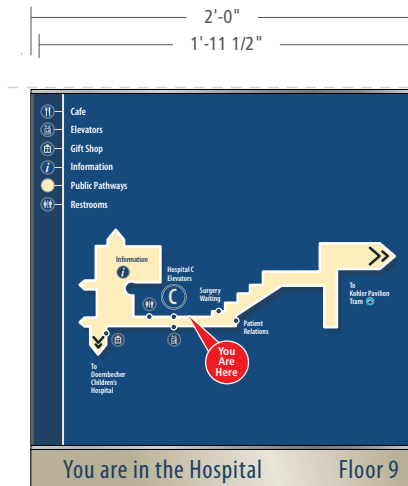
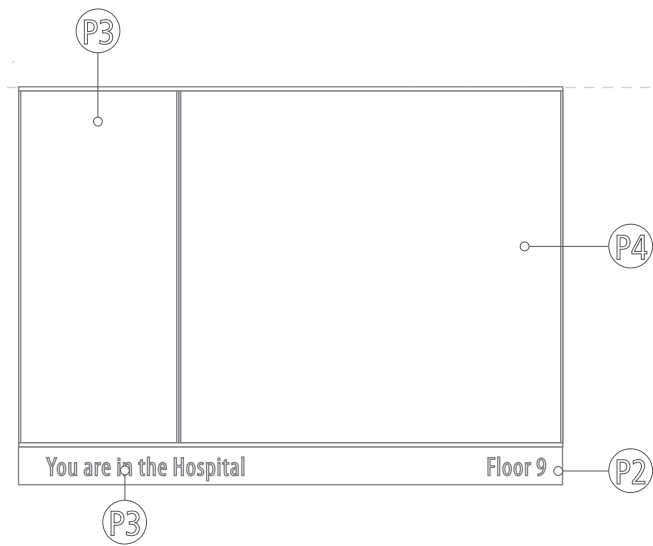

Similar construction to D-4b

**SIGN FRAME:**

APCO FullView FVS2224(H)MF - horizontal configuration, pin to be installed in the upper left position (with no pin), mounted to acrylic panel. Large format printed insert sits behind matte acrylic lens. Insert should fit tight against acrylic window for optimal appearance. Window is removed from frame with a suction cup tool using a lift/pull technique. Cabinet to be surface flush with decorative header above.

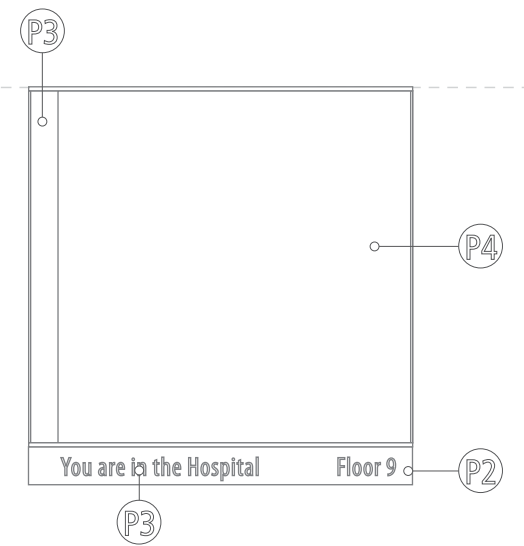

**D-4b STRIP MAP w/GUIDE INFO**  
Scale: 1"=1'-0" on an 11" x 17" sheet

**D-4c STRIP MAP**  
Scale: 1"=1'-0" on an 11" x 17" sheet

TOP VIEW

HATFIELD RESEARCH CENTER

SIDE VIEW

**CONSTRUCTION:**

Sign is fabricated from 1/4" (th.) painted Komacel panel with 1/4" (th.) painted acrylic accent bars. Letters are 1/4" (th.) acrylic painted white.

Size may vary from location to location. Corbin to provide an estimate for size. Fabricator to verify width on-site prior to fabrication.

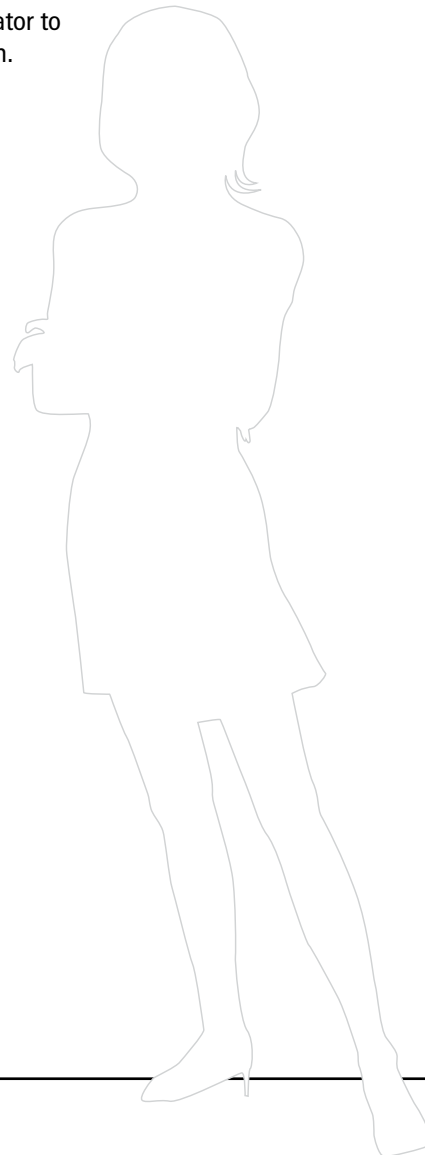

**EXAMPLE LAYOUTS**

MULTNOMAH PAVILION • FLOOR 3

DOERNBECHER CHILDREN'S HOSPITAL

MULTNOMAH PAVILION • FLOOR 3

DOERNBECHER CHILDREN'S HOSPITAL

**D-5 BUILDING/FLOOR TRANSITION SIGN, WALL-MOUNTED**

Scale: 1"=1'-0" on an 11" x 17" sheet

## GUIDES

To match thickness of APCO sign frame, approx 3/8" 1/8"

TOP VIEW

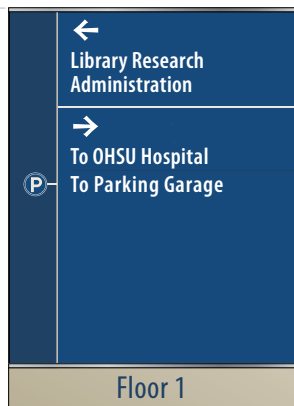
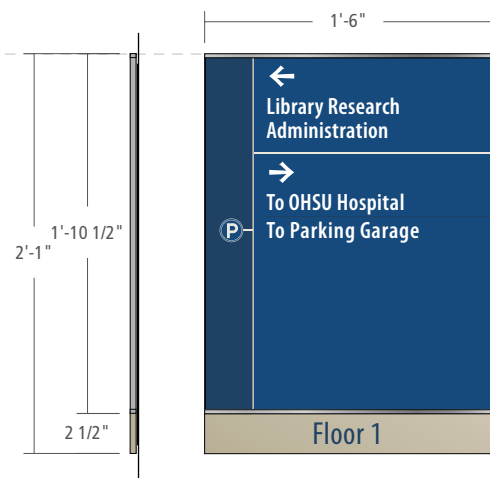

**BACKER PLATE:**

Constructed from 1/8" (th.) acrylic.

**SIGN FRAME:**

APCO FullView FVS2218(H)MF - horizontal configuration, pin to be installed in the upper left position, mounted to acrylic panel. Large format printed insert sits behind matte acrylic lens. Insert should fit tight against acrylic window for optimal appearance. Window is removed from frame with a suction cup tool using a lift/pull technique.

**FOOTER:**

Acrylic panel with silk-screened graphics. Panel thickness to equal thickness of APCO sign frame. Panel is mounted to backer panel.

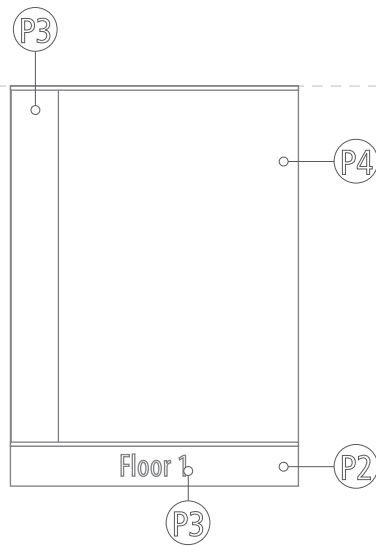

**EXAMPLE LAYOUTS**

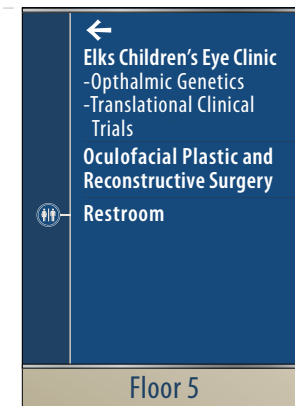
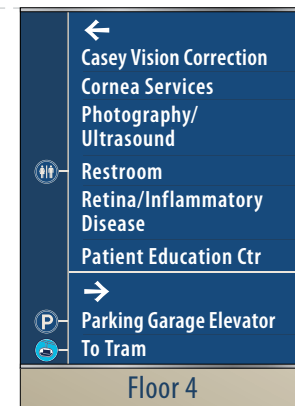
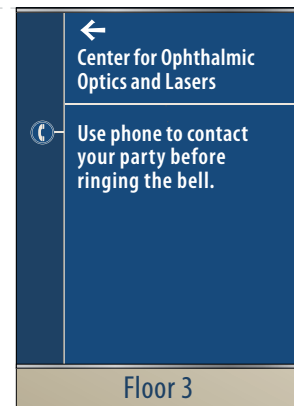

**G-2 GUIDE SIGN, LARGE**  
Scale: 1"=1'-0" on an 11" x 17" sheet

**APCO FULLVIEW**  
APCO FullView FVS2218(H)MF - horizontal configuration

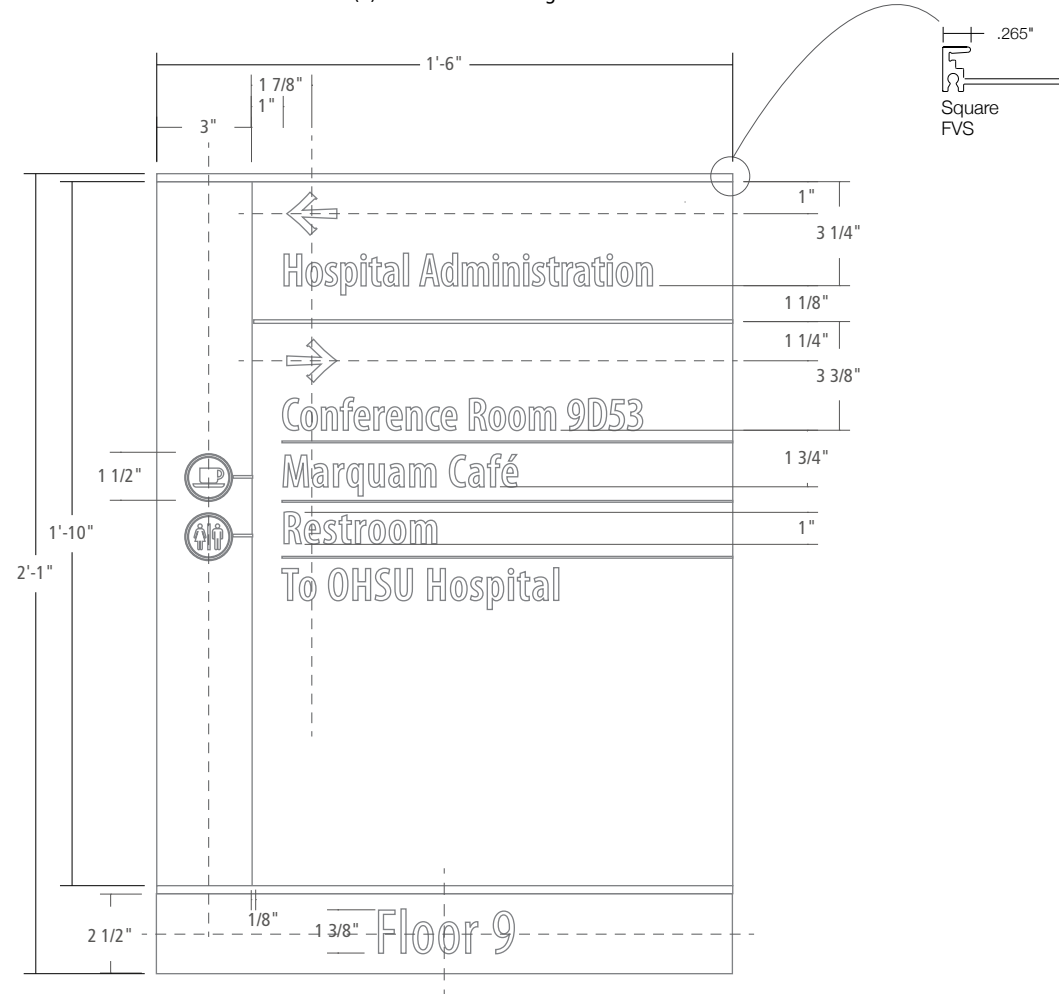

**TYPICAL DESTINATION TEXT:**  
Myriad Pro Semibold Condensed, 1" cap @ 25% kerning, set for optical display. Some destinations will require 5% or 10% kerning.

**CONFERENCE ROOM 9D53 TEXT:**  
Myriad Pro Semibold Condensed @ 10% kerning, set for optical display.

**HOSPITAL ADMINISTRATION TEXT:**  
Myriad Pro Semibold Condensed @ 5% kerning, set for optical display.

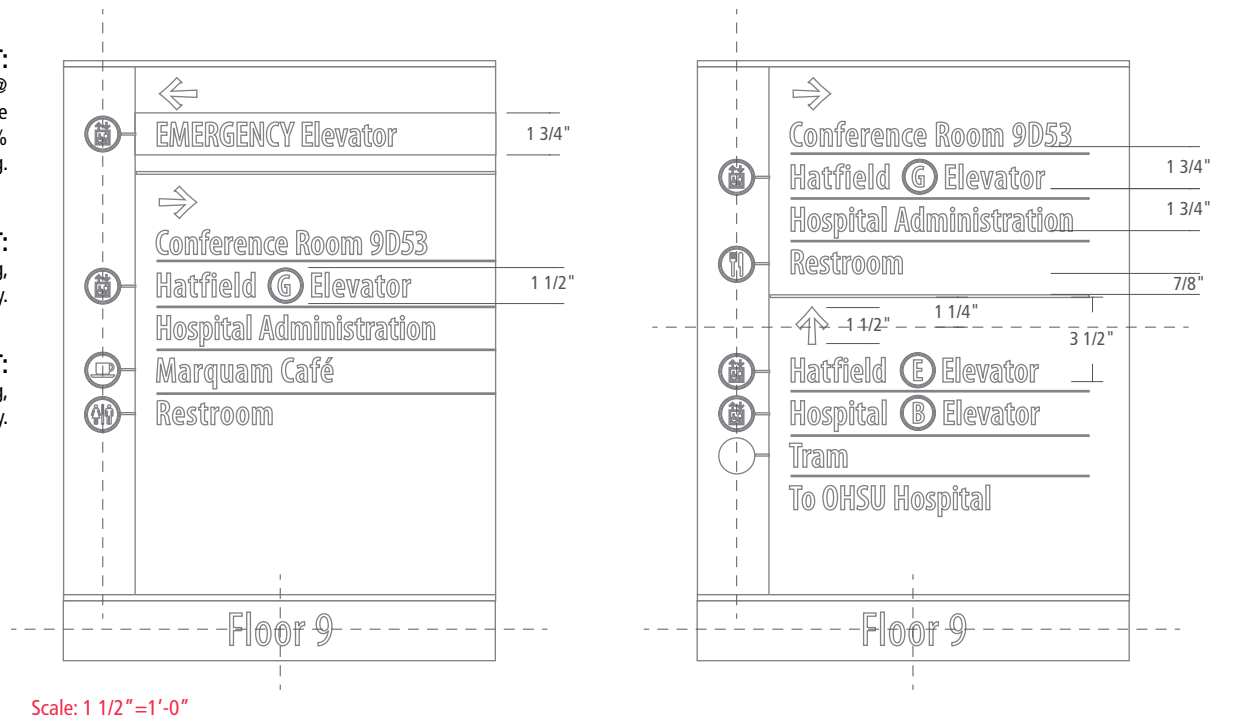

Scale: 1 1/2" = 1'-0"

**FOOTER TEXT:**  
Myriad Pro Condensed @ 25% kerning, set for optical display.

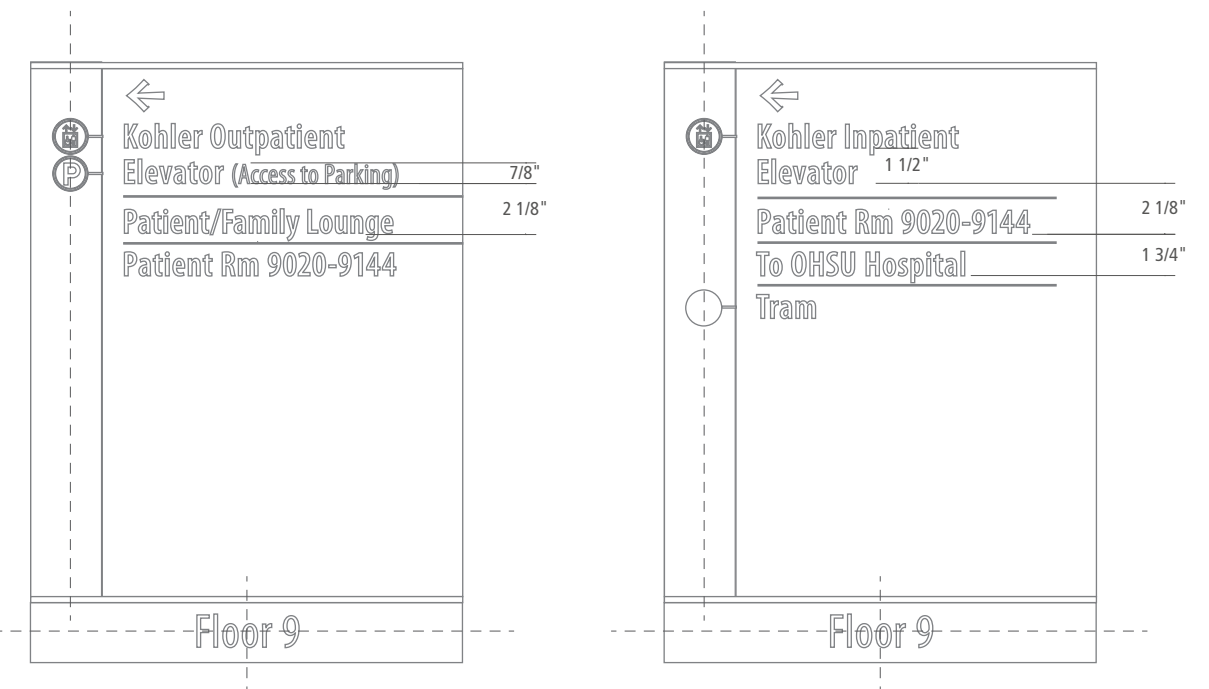

**G-2 GUIDE SIGN, LARGE, DETAIL**  
SPECIFICATION DETAILS  
Scale: 2" = 1'-0"

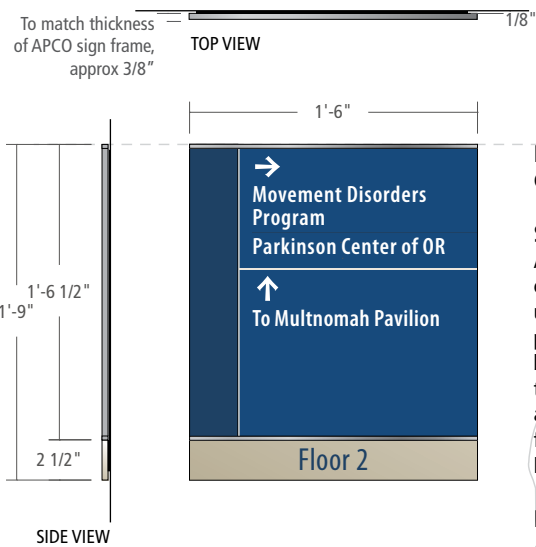

**BACKER PLATE:**

Constructed from 1/8" (th.) acrylic.

**SIGN FRAME:**

APCO FullView FVS1818(H)MF - horizontal configuration, pin to be installed in the upper left position, mounted to acrylic panel. Large format printed insert sits behind matte acrylic lens. Insert should fit tight against acrylic window for optimal appearance. Window is removed from frame with a suction cup tool using a lift/pull technique.

**FOOTER:**

Acrylic panel with silk-screened graphics. Panel thickness to equal thickness of APCO sign frame. Panel is mounted to backer panel.

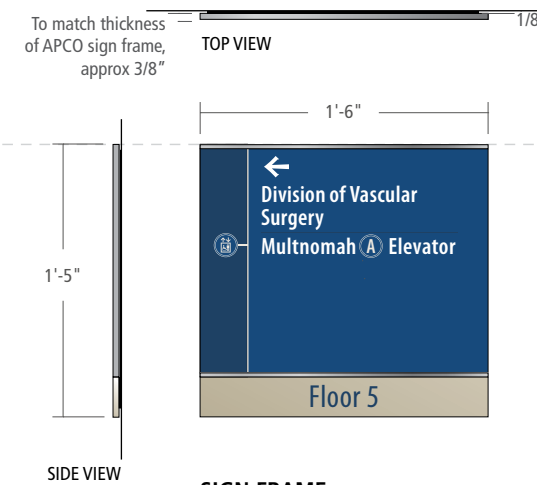
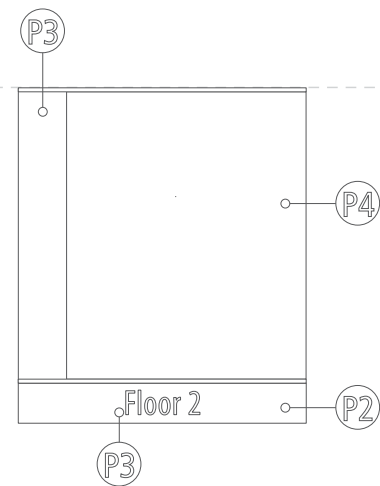

**SIGN FRAME:**

APCO FullView FVS1418(H)MF - horizontal configuration, pin to be installed in the upper left position, mounted to acrylic panel. Large format printed insert sits behind matte acrylic lens. Insert should fit tight against acrylic window for optimal appearance. Window is removed from frame with a suction cup tool using a lift/pull technique.

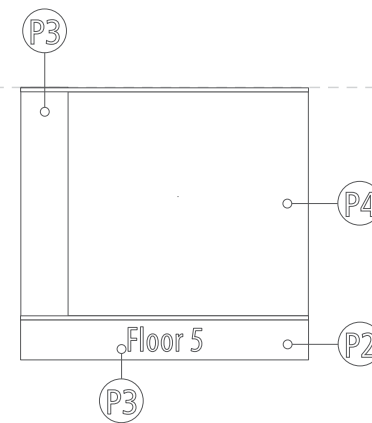

**EXAMPLE LAYOUT**

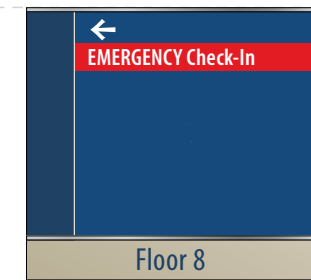

**G-2a GUIDE SIGN, MEDIUM**

Scale: 1"=1'-0" on an 11" x 17" sheet

**G-2b GUIDE SIGN, SMALL**

Scale: 1"=1'-0" on an 11" x 17" sheet

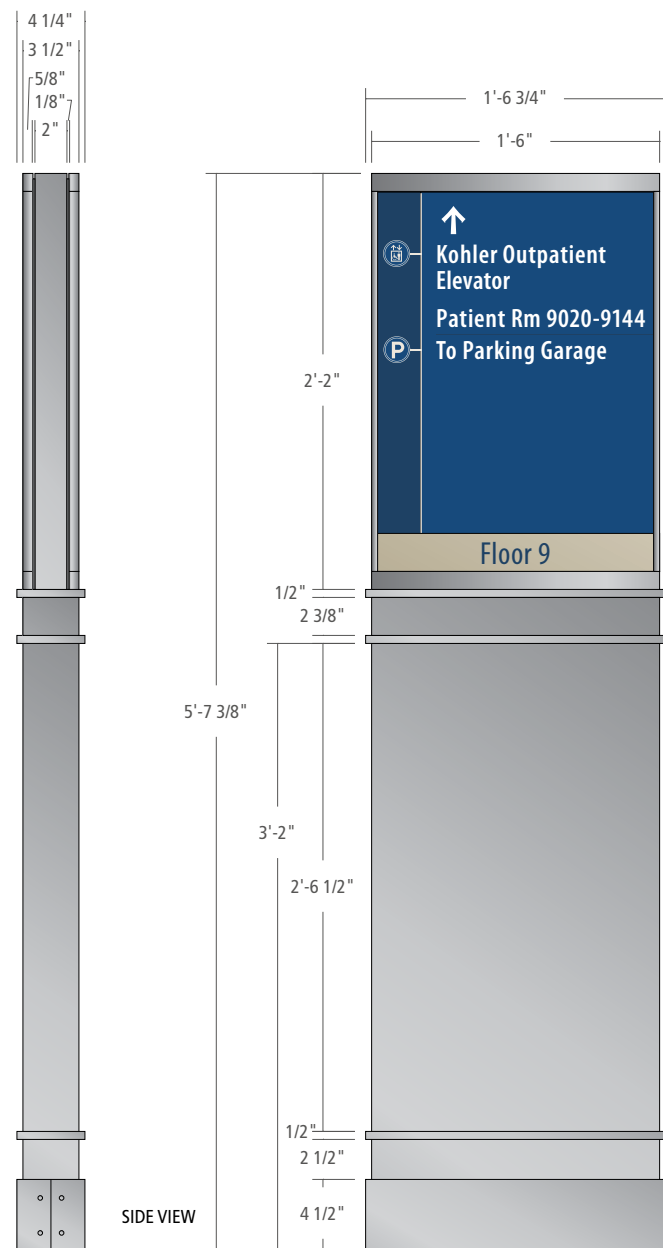

**FREESTANDING GUIDE:**

Double-sided freestanding guide sign fabricated out of 1/8" (th.) painted aluminum.

**DIRECTORY CABINET:**

APCO FullView Large Assembly sign - horizontal configuration with vertical divider bar. Mounted to central support, signs should be flush with Header above. Large format printed inserts sit behind matte acrylic lens. Inserts should fit tight against acrylic window for optimal appearance. Window is removed from frame with a suction cup tool using a lift/pull technique. 1'-6" w x 2'-2" h

**ACCENT BARS:**

1/2" (th.) aluminum bars mechanically fastened (or welded) to the cabinet.

**REMOVABLE BASE:**

Lower kickplate is removable (by counter-sunk screws on the side of the kiosk) to reveal mounting hardware. Fabricator to engineer sign mounting (must be secured to the floor).

**G-3 GUIDE SIGN, FREESTANDING**

Scale: 1"=1'-0" on an 11" x 17" sheet

**BACK OF CABINET w/o INSERT**

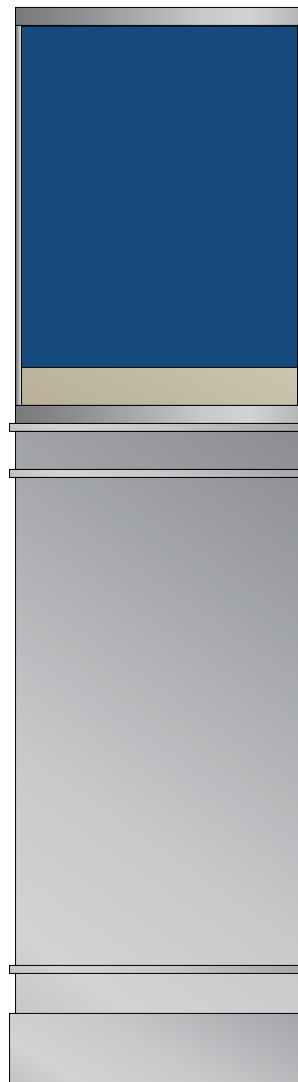

**TYPICAL DESTINATION TEXT:**

Myriad Pro Semibold Condensed @ 25% kerning, set for optical display. Some destinations will require 0% to 10% kerning.

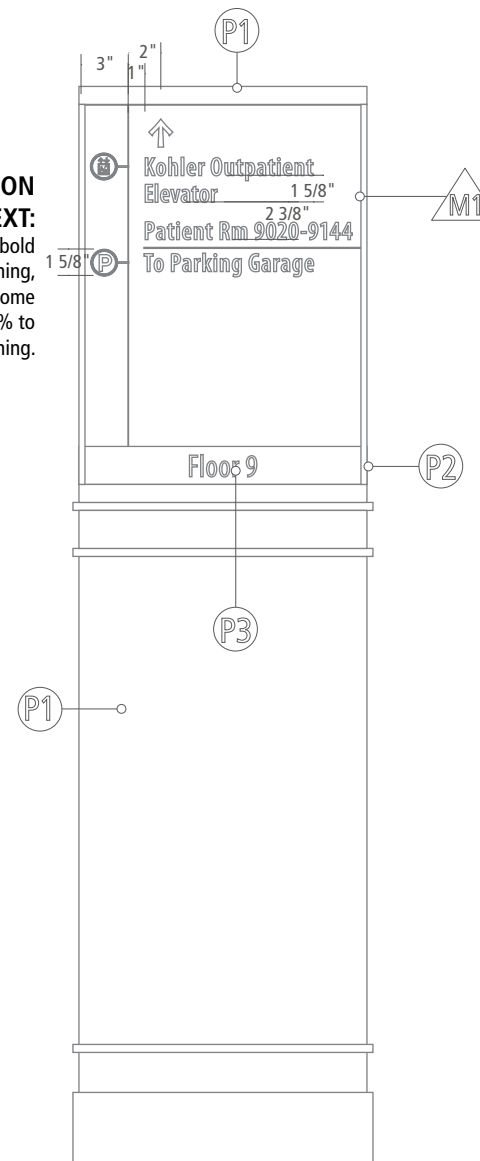

**TWO LINE DESTINATION:**

The destination following a two lined destination should be 2 3/8" from baseline to baseline. This is only for destinations following a two line destination. All others are spaced 2" from baseline to baseline.

**FOOTER FONT:**

Myriad Pro Condensed @ 20% kerning. Kerning set for Optical.



## OVERHEADS

**O-1a PROJECTING IDENTIFIER, LARGE, CEILING MOUNT**

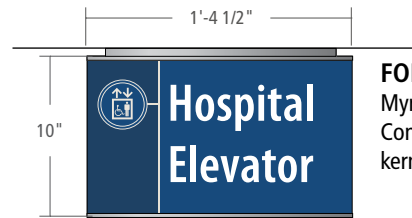

**FONT:**  
Myriad Pro SemiBold  
Condensed @ 25%  
kerning.

**SIGN CABINET:**

APCO FullView Standard Assembly - horizontal configuration, FVS10165(H)CMF. Large format printed insert sits behind matte acrylic lens. Insert should fit tight against acrylic window for optimal appearance.

**EXAMPLE LAYOUTS**

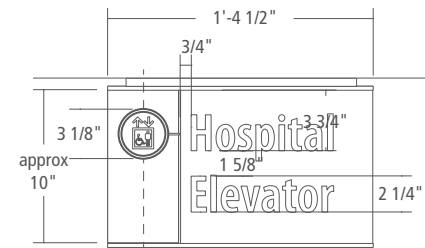

**FONT:**  
Myriad Pro SemiBold Condensed optical  
kerning @ 25%.

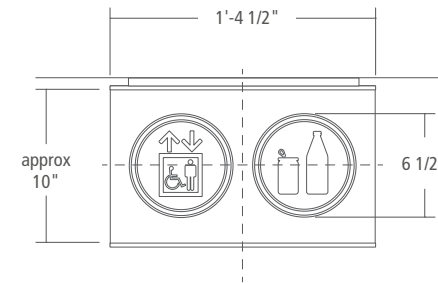
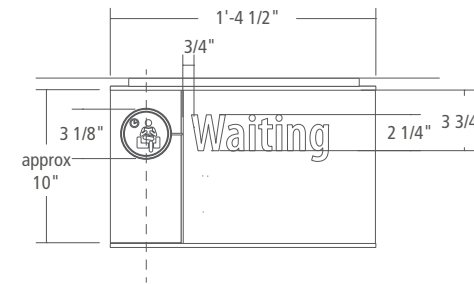

**O-1b PROJECTING IDENTIFIER, LARGE, WALL MOUNT**



**SIGN CABINET:**

APCO FullView Standard Assembly - horizontal configuration, FVS10165(H)CMW. Large format printed insert sits behind matte acrylic lens. Insert should fit tight against acrylic window for optimal appearance.

**O-1a,b OVERHEAD, PROJECTING ID/GUIDE**

Scale: 1"=1'-0" on an 11" x 17" sheet

**O-1c PROJECTING IDENTIFIER, MEDIUM, CEILING MOUNT**

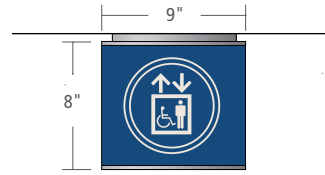

**SIGN CABINET:**  
 APCO FullView Standard Assembly - horizontal configuration, FVS0809(H)CMF. Large format printed insert sits behind matte acrylic lens. Insert should fit tight against acrylic window for optimal appearance.

**EXAMPLE LAYOUTS**

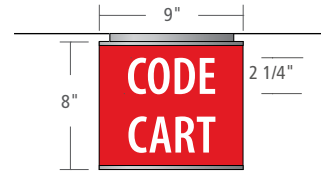

**FONT:**  
 Myriad Pro SemiBold Condensed @ 25% kerning.

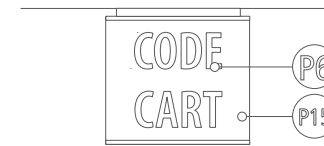
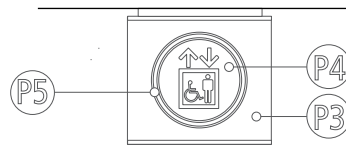
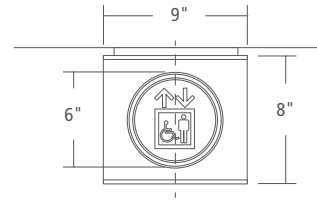

**NOTE:**  
 This sign is required by OHSU at Code Cart locations. Wall mount or ceiling mount as needed.

**O-1d PROJECTING IDENTIFIER, MEDIUM, WALL MOUNT**

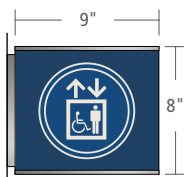

**SIGN CABINET:**  
 APCO FullView Standard Assembly - horizontal configuration, FVS0809(H)C-MW Large format printed insert sits behind matte acrylic lens. Insert should fit tight against acrylic window for optimal appearance.

**O-1c,d OVERHEAD, PROJECTING ID/GUIDE**  
 Scale: 1"=1'-0" on an 11" x 17" sheet

**O-1e PROJECTING IDENTIFIER, SMALL, CEILING MOUNT**

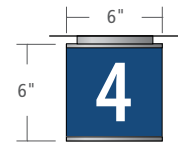

**SIGN CABINET:**

APCO FullView Standard Assembly - horizontal configuration, FVS0606(H)CMF. Large format printed insert sits behind matte acrylic lens. Insert should fit tight against acrylic window for optimal appearance.

**EXAMPLE LAYOUTS**

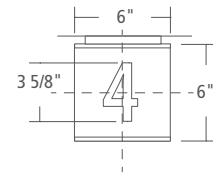

**FONT:**  
Myriad Pro SemiBold  
Condensed @ 25%  
kerning.

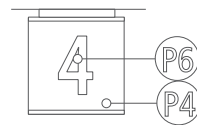

**O-1f PROJECTING IDENTIFIER, SMALL, WALL MOUNT**

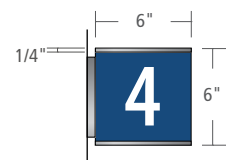

**SIGN CABINET:**

APCO FullView Standard Assembly - horizontal configuration, FVS0606(H)C-MW. Large format printed insert sits behind matte acrylic lens. Insert should fit tight against acrylic window for optimal appearance.

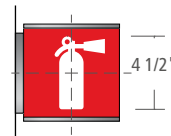

**NOTE:**

This sign is required by OHSU at all fire extinguisher locations. Wall mount or ceiling mount as needed.

**O-1e,f OVERHEAD, PROJECTING ID/GUIDE**

Scale: 1"=1'-0" on an 11" x 17" sheet

**O-1g PROJECTING IDENTIFIER, CEILING MOUNT**

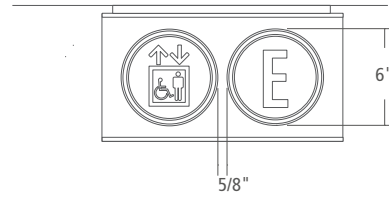
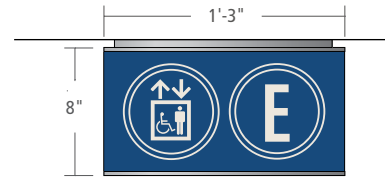

**SIGN CABINET:**  
 APCO FullView Standard Assembly - horizontal configuration, FVS0815(H)CMF. Large format printed insert sits behind matte acrylic lens. Insert should fit tight against acrylic window for optimal appearance.

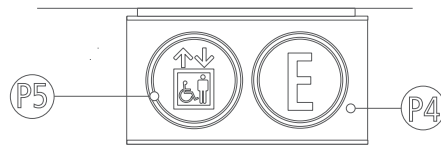
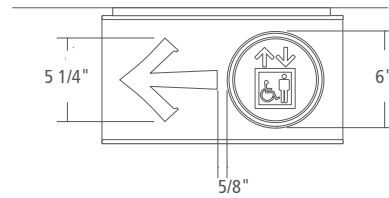

**O-1h PROJECTING IDENTIFIER, WALL MOUNT**

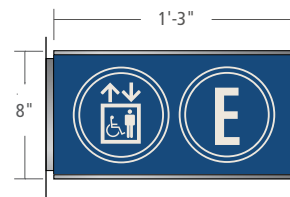

**SIGN CABINET:**  
 APCO FullView Standard Assembly - horizontal configuration, FVS0815(H)CMF. Large format printed insert sits behind matte acrylic lens. Insert should fit tight against acrylic window for optimal appearance.

**O-1g,h OVERHEAD, PROJECTING ID/GUIDE**  
 Scale: 1"=1'-0" on an 11" x 17" sheet

O-2 OVERHEAD IDENTIFIER/GUIDE, DOUBLE-SIDED, CEILING MOUNTED

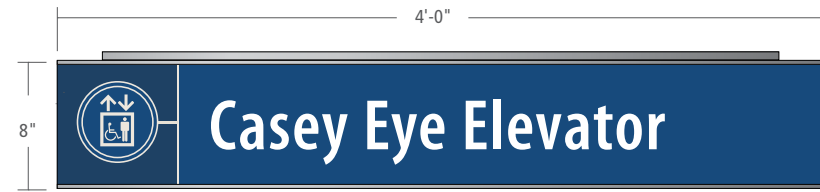

Insert with symbol

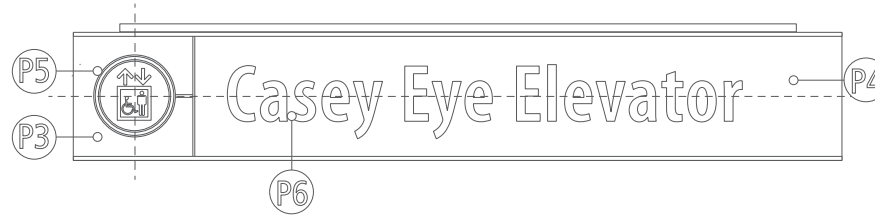

O-2 OVERHEAD IDENTIFIER/GUIDE, DOUBLE-SIDED, CEILING MOUNTED



Insert without symbol



O-2a OVERHEAD IDENTIFIER/GUIDE, SINGLE-SIDED, WALL MOUNTED



MOUNTING EXAMPLES

O-2 OVERHEAD IDENTIFIER/GUIDE, DOUBLE-SIDED, CEILING MOUNTED FLUSH



**SIGN CABINET:**  
APCO FullView Standard Assembly - horizontal configuration, FVS0848(H)CMF. Large format printed insert sits behind matte acrylic lens. Insert should fit tight against acrylic window for optimal appearance.

OR

O-2 OVERHEAD IDENTIFIER/GUIDE, DOUBLE-SIDED, CEILING MOUNTED SUSPENDED



**SIGN CABINET:**  
APCO FullView Standard Assembly - horizontal configuration, FVS0848(H)CMW. Large format printed insert sits behind matte acrylic lens. Insert should fit tight against acrylic window for optimal appearance.

O-2a OVERHEAD IDENTIFIER/GUIDE, SINGLE-SIDED, WALL MOUNTED



**SIGN CABINET:**  
APCO FullView Standard Assembly - horizontal configuration, FVS0848(H). Large format printed insert sits behind matte acrylic lens. Insert should fit tight against acrylic window for optimal appearance.

O-2, O-2a OVERHEAD ID/GUIDES  
Scale: 1"=1'-0" on an 11" x 17" sheet

EXAMPLE LAYOUTS

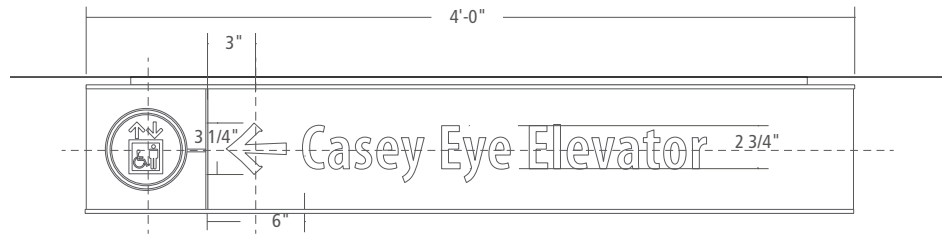

**FONT:**  
Myriad Pro Semibold  
Condensed @ 25%  
kerning.

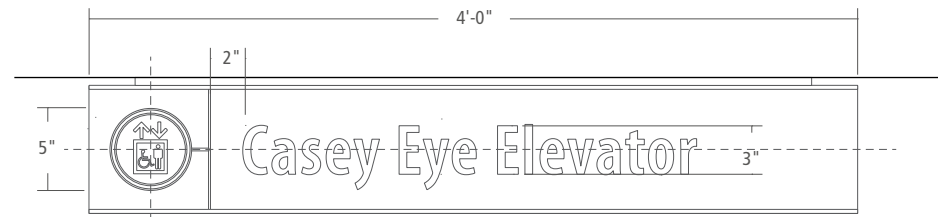

**FONT:**  
Myriad Pro Semibold  
Condensed @ 25%  
kerning.



**FONT:**  
Myriad Pro Semibold  
Condensed @ 25%  
kerning.



**FONT:**  
Myriad Pro Semibold  
Condensed @ 25%  
kerning.



**FONT:**  
Myriad Pro Semibold  
Condensed @ 5%  
kerning.



**FONT:**  
Myriad Pro Semibold  
Condensed @ 5%  
kerning.

O-2, O-2a OVERHEAD ID/GUIDE DETAIL  
Scale: 1"=1'-0" on an 11" x 17" sheet

**O-3 GUIDE, LARGE, DOUBLE-SIDED, CEILING MOUNTED**

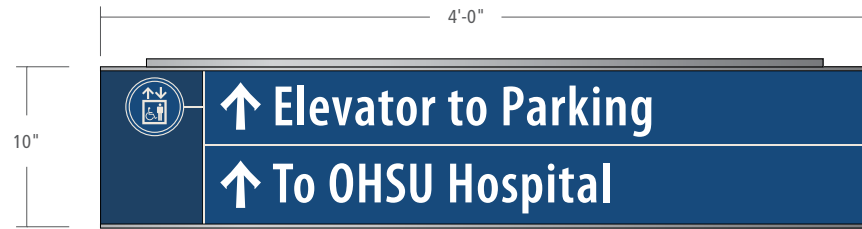

**SIGN CABINET:**

APCO FullView Standard Assembly - horizontal configuration, FVS1048(H)CMF. Large format printed insert sits behind matte acrylic lens. Insert should fit tight against acrylic window for optimal appearance.

**O-3a OVERHEAD GUIDE, LARGE, DOUBLE-SIDED, CEILING MOUNTED**



**SIGN CABINET:**

APCO FullView Standard Assembly - horizontal configuration, FVS1048(H)CMW. Large format printed insert sits behind matte acrylic lens. Insert should fit tight against acrylic window for optimal appearance.

**O-3a OVERHEAD GUIDE, LARGE, SINGLE-SIDED, WALL MOUNTED**



**SIGN CABINET:**

APCO FullView Standard Assembly - horizontal configuration, FVS1048(H). Large format printed insert sits behind matte acrylic lens. Insert should fit tight against acrylic window for optimal appearance.

**EXAMPLE LAYOUTS**

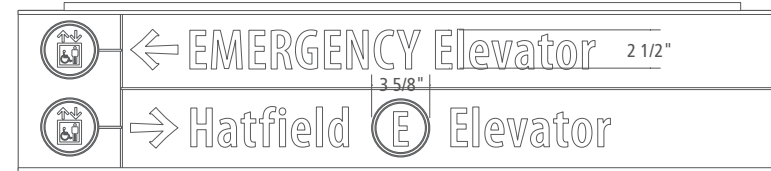

**O-3 OVERHEAD GUIDE, DOUBLE-SIDED, CEILING MOUNTED FLUSH**



OR

**O-3 OVERHEAD GUIDE, DOUBLE-SIDED, CEILING MOUNTED SUSPENDED**

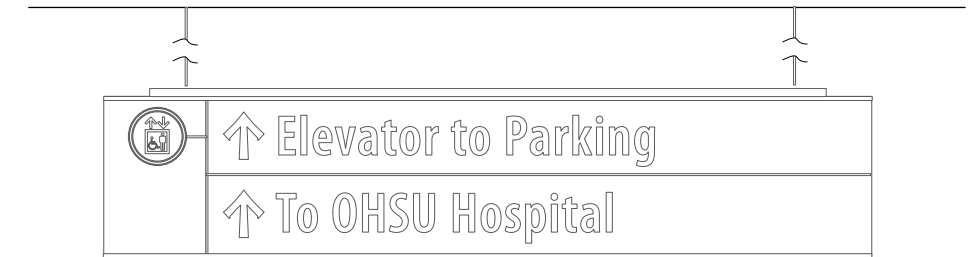

**FONT:**

Myriad Pro Semibold  
Condensed @ 5%  
kerning.

**O-3 & O-3a OVERHEAD GUIDES**

Scale: 1"=1'-0" on an 11" x 17" sheet



O-4a PROJECTING IDENTIFIER/GUIDE, CEILING MOUNTED

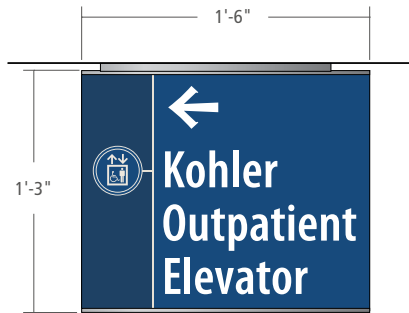

**SIGN CABINET:**

APCO FullView Standard Assembly - horizontal configuration, FVS15165(H)CMF. Large format printed insert sits behind matte acrylic lens. Insert should fit tight against acrylic window for optimal appearance.

**FONT:**

Myriad Pro SemiBold Condensed @ 10% kerning.

O-4b PROJECTING IDENTIFIER/GUIDE, WALL MOUNTED



**SIGN CABINET:**

APCO FullView Standard Assembly - horizontal configuration, FVS15165(H)CMW. Large format printed insert sits behind matte acrylic lens. Insert should fit tight against acrylic window for optimal appearance.

**FONT:**

Myriad Pro SemiBold Condensed @ 10% kerning.

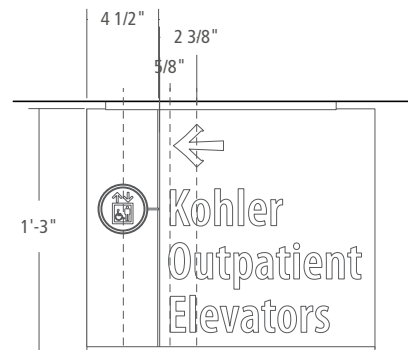
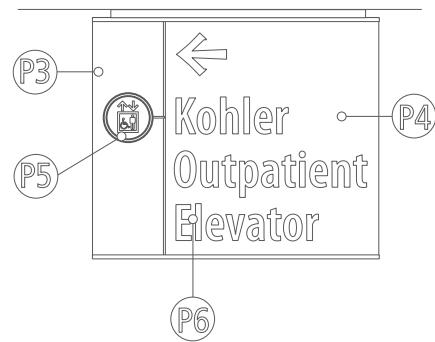

**FONT:**

Myriad Pro SemiBold Condensed @ 10% kerning.



O-4a & O-4b PROJECTING ID/GUIDES

Scale: 1"=1'-0" on an 11" x 17" sheet

O-5 OVERHEAD GUIDE, DOUBLE-SIDED, CEILING MOUNTED

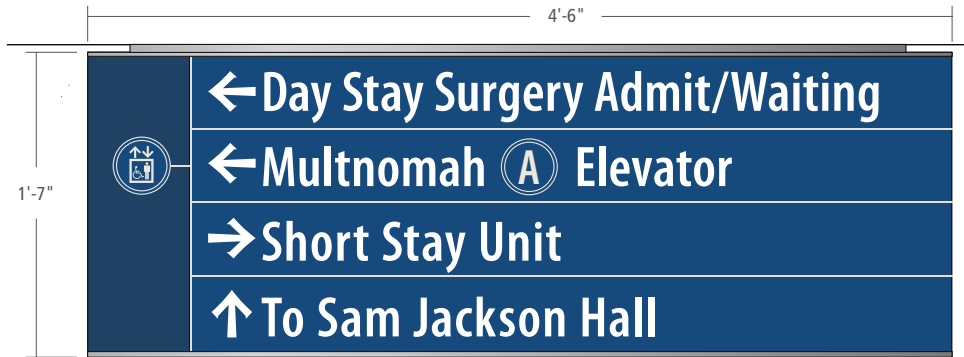

**SIGN:**  
 Message panels are fabricated from two 1/4" (th.) painted Komacel panels mounted back-to-back using APCO aluminum mounting bracket with square profile. Sign edges to be painted to match face. Messaging to be surface applied vinyl graphics. Sign top and bottom edges to have break-formed aluminum trim fabricated from .090 (th.) aluminum. Sign is mounted using APCO extruded aluminum mounting bracket.

O-5b OVERHEAD GUIDE, DOUBLE-SIDED, CEILING MOUNT

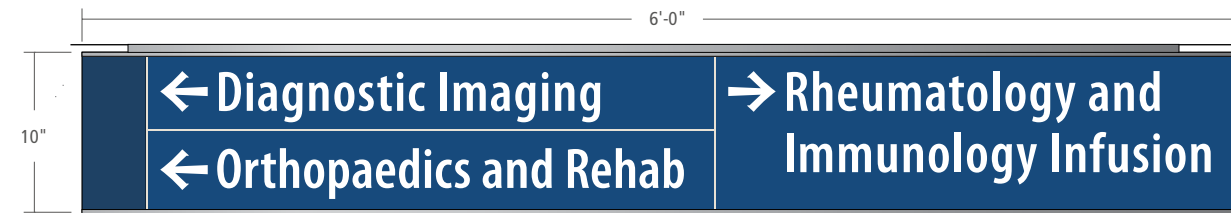

**SIGN:**  
 Message panels are fabricated from two 1/4" (th.) painted Komacel panels mounted back-to-back using APCO aluminum mounting bracket with square profile. Sign edges to be painted to match face. Messaging to be surface applied vinyl graphics. Sign top and bottom edges to have break-formed aluminum trim fabricated from .090 (th.) aluminum. Sign is mounted using APCO extruded aluminum mounting bracket.

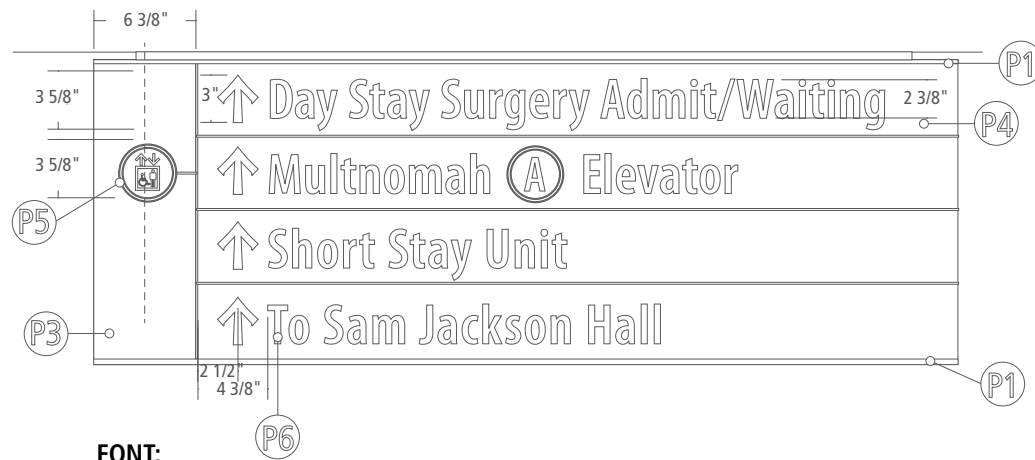

**FONT:**  
 Myriad Pro SemiBold  
 Condensed @ 25% kerning.

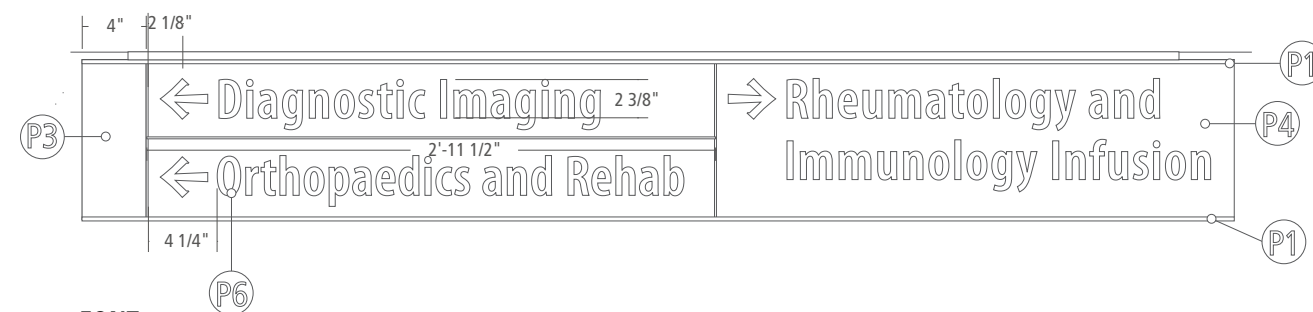

**FONT:**  
 Myriad Pro SemiBold  
 Condensed @ 25% kerning.

O-5 OVERHEAD GUIDE, DOUBLE-SIDED, CEILING MOUNT  
 Scale: 1" = 1'-0" on an 11" x 17" sheet

O-5b OVERHEAD GUIDE, DOUBLE-SIDED, CEILING MOUNT  
 Scale: 1" = 1'-0" on an 11" x 17" sheet

O-6 OVERHEAD IDENTIFIER/GUIDE, DOUBLE-SIDED, CEILING MOUNTED



**SIGN CABINET:**

APCO FullView Standard Assembly - horizontal configuration, FVS0836(H)CMF. Large format printed insert sits behind matte acrylic lens. Insert should fit tight against acrylic window for optimal appearance.

**FONT:**

Myriad Pro SemiBold  
Condensed @ 25%  
kerning.



O-6 OVERHEAD ID/GUIDE, CEILING MOUNT  
Scale: 1" = 1'-0" on an 11" x 17" sheet

O-6a OVERHEAD IDENTIFIER/GUIDE, SINGLE-SIDED, WALL MOUNTED



**SIGN CABINET:**

APCO FullView Standard Assembly - horizontal configuration, FVS0836(H)CMF. Large format printed insert sits behind matte acrylic lens. Insert should fit tight against acrylic window for optimal appearance.

**FONT:**

Myriad Pro SemiBold  
Condensed @ 25%  
kerning.



O-6a OVERHEAD ID/GUIDE, WALL MOUNT  
Scale: 1" = 1'-0" on an 11" x 17" sheet

O-6 OVERHEAD IDENTIFIER/GUIDE, DOUBLE-SIDED, CEILING MOUNTED

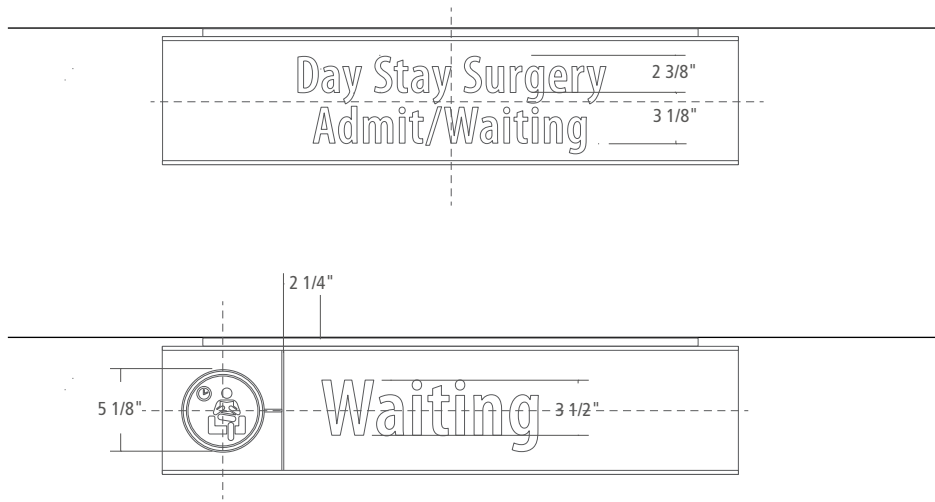

**FONT:**  
 Myriad Pro SemiBold  
 Condensed @ 25%  
 kerning.

O-6a OVERHEAD IDENTIFIER/GUIDE, SINGLE-SIDED, WALL MOUNTED

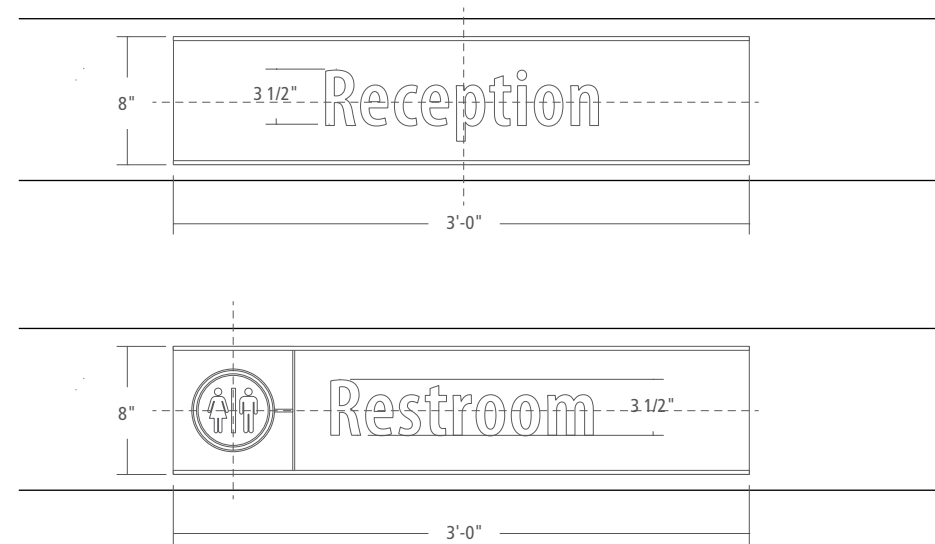

**FONT:**  
 Myriad Pro SemiBold  
 Condensed @ 25%  
 kerning.

O-6 OVERHEAD ID/GUIDE CEILING MOUNT DETAIL  
 Scale: 1"=1'-0" on an 11" x 17" sheet

O-6a OVERHEAD ID/GUIDE, WALL MOUNTED DETAIL  
 Scale: 1"=1'-0" on an 11" x 17" sheet

## IDENTIFIERS

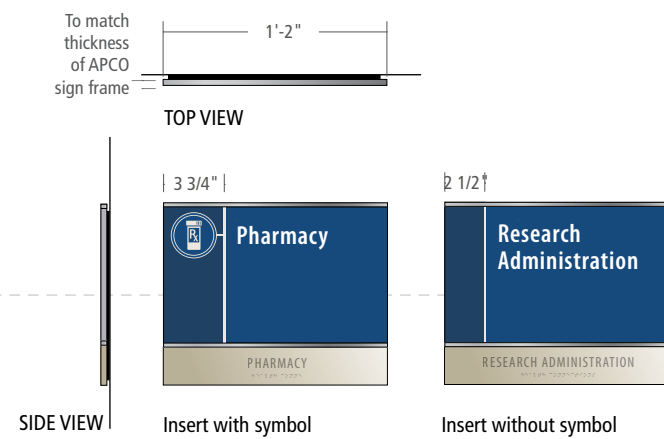

**BACKER PLATE:**  
Constructed from 1/8" (th.) acrylic.

**SIGN FRAME:**  
APCO FullView FVS8514(H)MF - horizontal configuration, pin to be installed in the upper left position, mounted to acrylic panel. Large format printed insert sits behind matte acrylic lens. Insert should fit tight against acrylic window for optimal appearance. Window is removed from frame with a suction cup tool using a lift/pull technique.

**FOOTER:**  
Acrylic panel with tactile and Braille characters. Tactile letters and Braille painted background color. Panel thickness to equal thickness of APCO sign frame. Panel is mounted to backer panel.

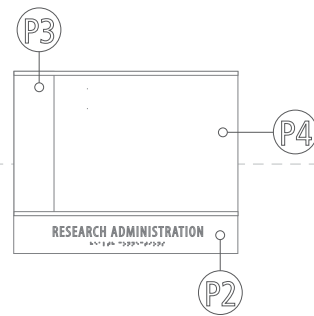

**EXAMPLE LAYOUTS**

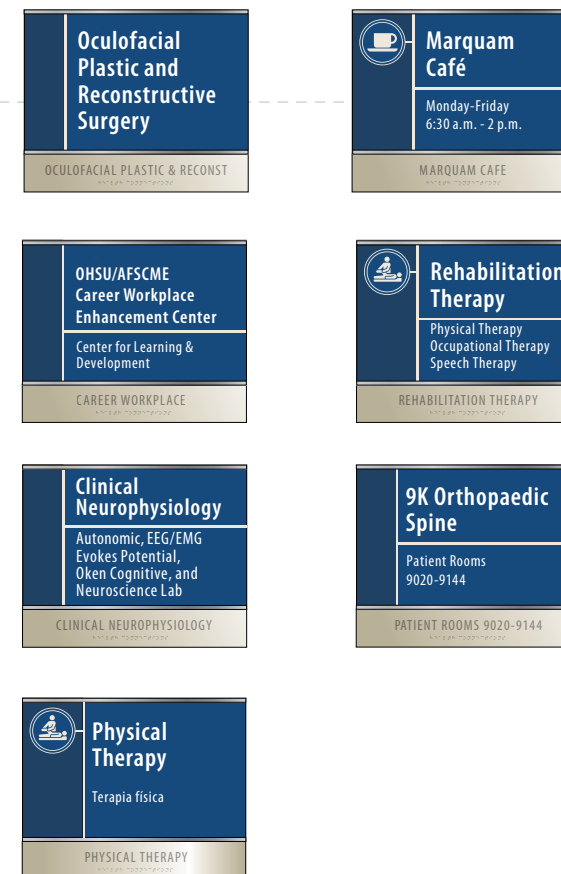

**I-1b PRIMARY ID**  
Scale: 1"=1'-0" on an 11" x 17" sheet

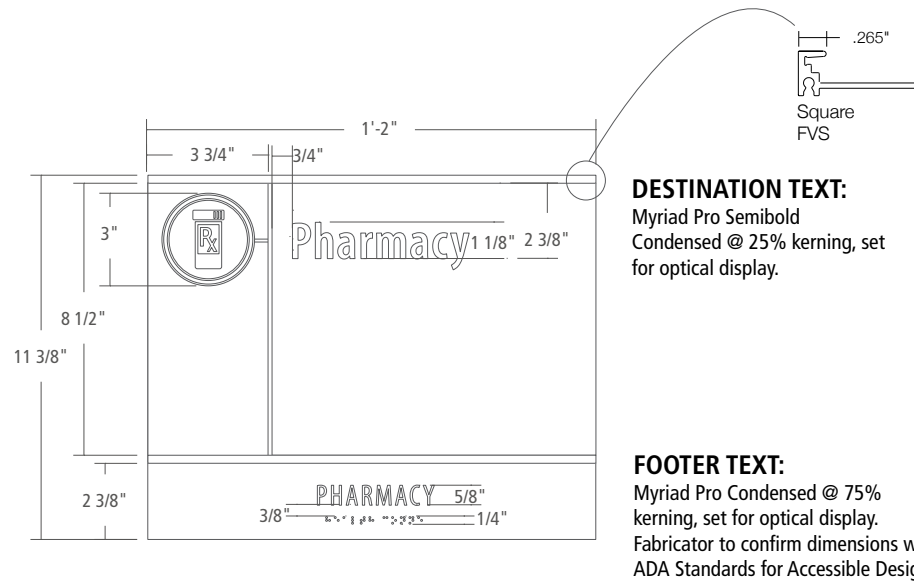

**EXAMPLE LAYOUTS**

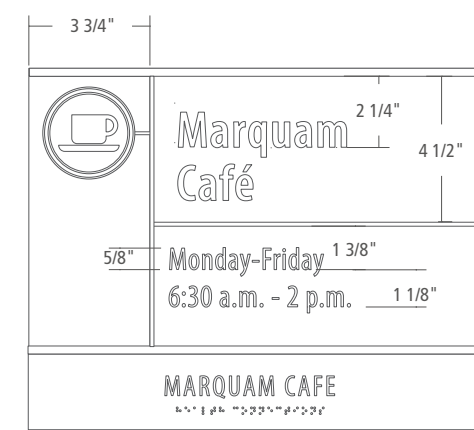
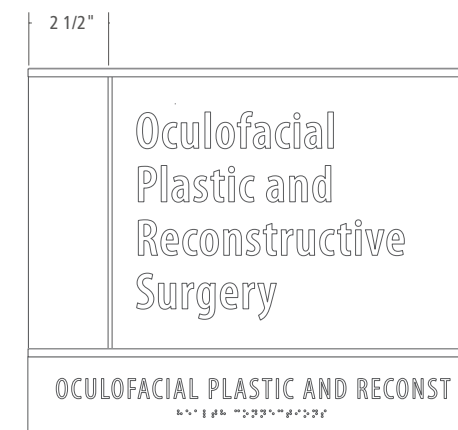

**HOURS OF OPERATION TEXT:**  
Myriad Pro Condensed @ 25% kerning, set for optical display.



**SUB-SPECIALITY TEXT:**  
Myriad Pro Condensed @ 25% kerning, set for optical display.

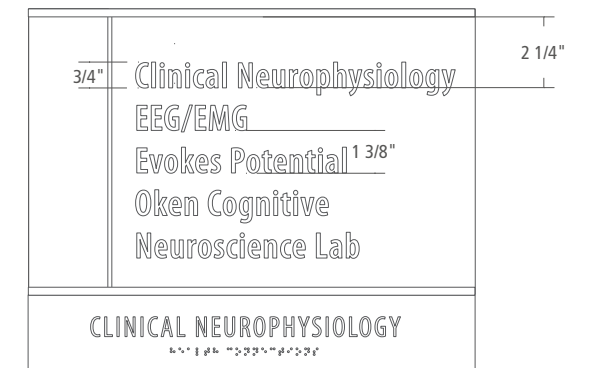
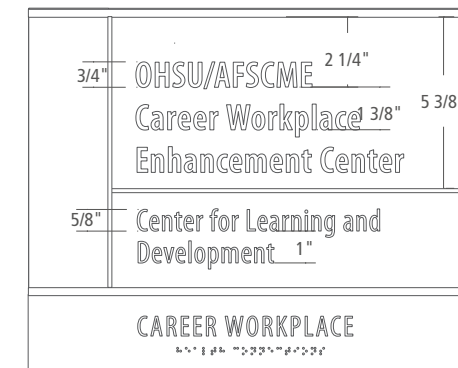

**TEXT FOR LONG NAMES:**  
3/4" (h.) Myriad Pro Condensed @ 25% kerning, set for optical display.

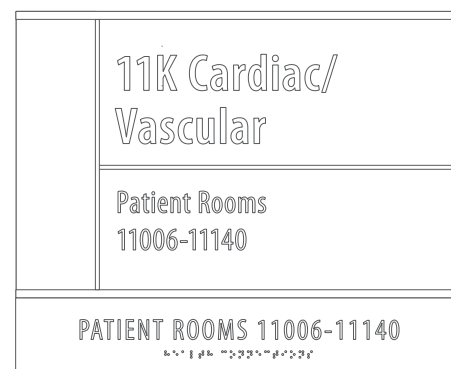

**PATIENT ROOMS TEXT:**  
Myriad Pro Condensed @ 25% kerning, set for optical display.



**SPANISH TEXT:**  
Myriad Pro Condensed @ 25% kerning, set for optical display.

**I-1b PRIMARY ID DETAIL**  
SPECIFICATION DETAILS  
Scale: 2"=1'-0"

**NOTIFIER BAR:**

APCO Notifier Message Strip mounted to backer plate, aligned flush with the bottom of the sign. Notifier bar should be the same width of sign cabinet so edges of the bar are flush with the edges of the sign cabinet.

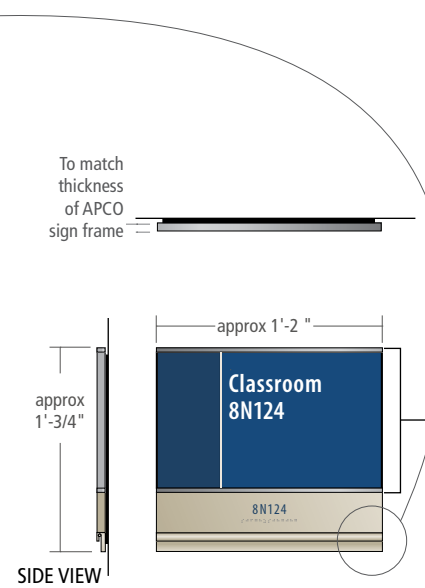

**BACKER PLATE:**

1/8" thick acrylic panel mounted to the wall.

**CABINET:**

APCO FullView Standard Assembly - horizontal configuration, FVS8514(H)MF. Sign frame is mounted to acrylic backer plate. Large format printed insert sits behind matte acrylic lens. Insert should fit tight against acrylic window for optimal appearance. Sign footer is flush with surface of sign cabinet. Window is removed from frame with a suction cup tool using a lift/pull technique.

**FOOTER:**

Acrylic panel with tactile and Braille characters. Tactile letters painted, Braille painted background color. Panel thickness to equal thickness of APCO sign frame. Panel is mounted to backer plate. Sign footer is flush with surface of sign cabinet.

**NOTIFIER BAR:**

APCO Notifier Message Strip mounted to backer plate, aligned flush with the bottom of the sign. Notifier bar should be the same width of sign cabinet so edges of the bar are flush with the edges of the sign cabinet.

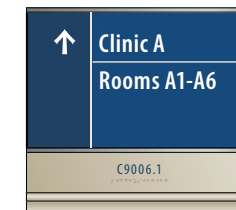
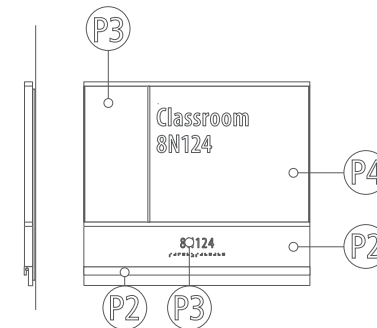

**I-1c CLASSROOM/LAB ID w/ NOTIFIER BAR**

Scale: 1"=1'-0" on an 11" x 17" sheet



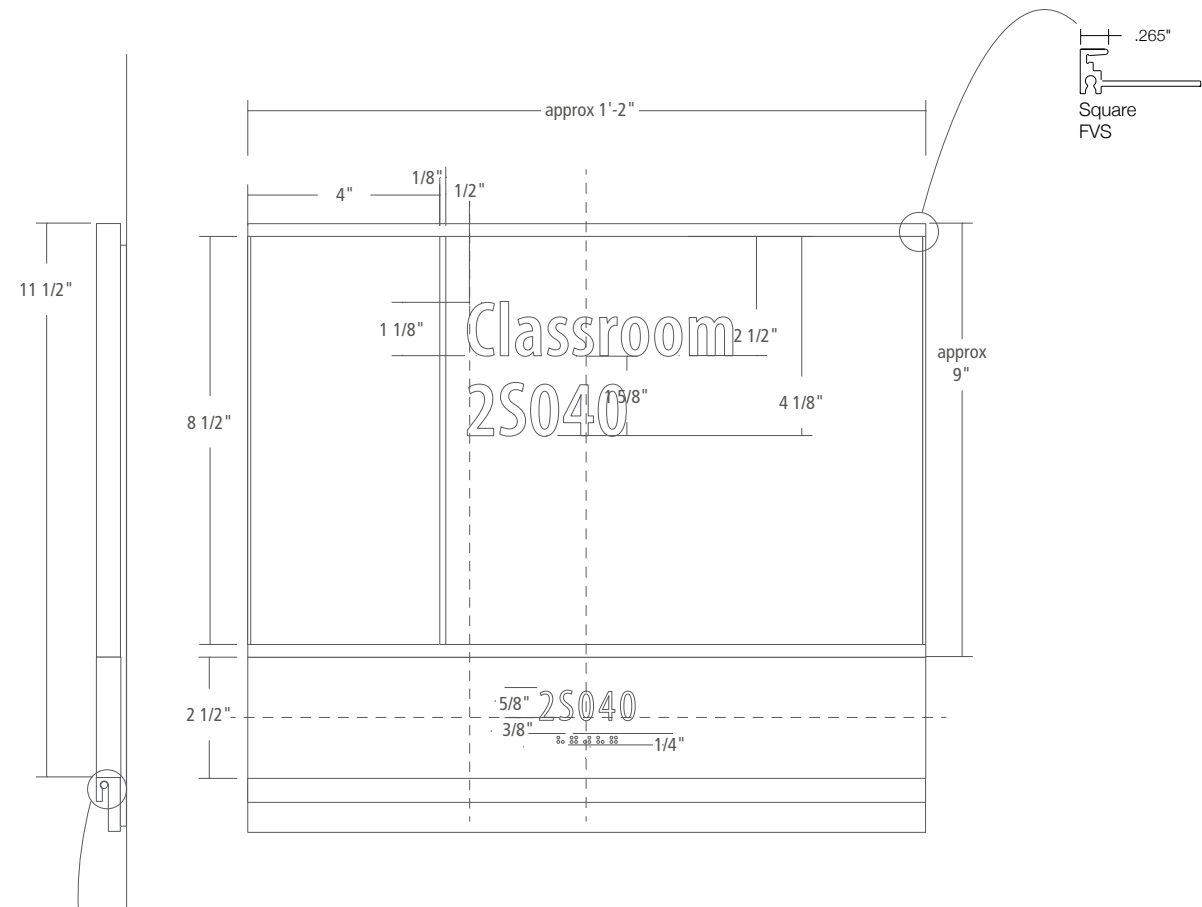

Scale: 3"=1'-0"

**DESTINATION TEXT:**

Myriad Pro Semibold  
Condensed @ 20% kerning, set  
for optical display.

**FOOTER TEXT:**

Myriad Pro Condensed @ 75%  
kerning, set for optical display.  
Fabricator to confirm  
dimensions with ADA  
Standards for Accessible  
Design.

**NOTIFIER BAR:**

APCO Notifier Message Strip mounted  
to backer plate, aligned flush with the  
bottom of the sign. Notifier bar should  
be flush with surface of sign. If  
necessary, an acrylic spacer can be added  
to the back of the notifier bar to allow  
flush alignment with sign face.

**I-1c CLASSROOM/LAB ID w/ NOTIFIER BAR**  
SPECIFICATION DETAILS  
Scale: 3"=1'-0"

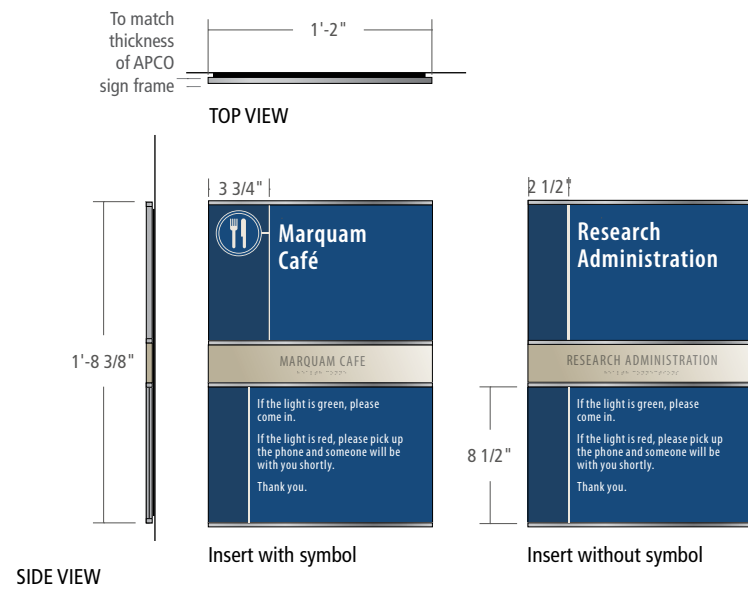

**BACKER PLATE:**  
Constructed from 1/8" (th.) acrylic.

**SIGN FRAME:**  
APCO FullView FVS8514(H)MF - horizontal configuration, pin to be installed in the upper left position, mounted to acrylic panel. Large format printed insert sits behind matte acrylic lens. Insert should fit tight against acrylic window for optimal appearance. Window is removed from frame with a suction cup tool using a lift/pull technique.

**FOOTER:**  
Acrylic panel with tactile and Braille characters. Tactile letters and Braille painted background color. Panel thickness to equal thickness of APCO sign frame. Panel is mounted to backer panel.

**INSERT FRAME:**  
APCO FullView FVS8514(IA)MF - to allow for 8 1/2" x 14" changeable notice. Frame is mounted to acrylic backer panel. Left side of holder to be filled with painted acrylic panel separated from insert holder by a blocking strip. Notice is changed by inserting a sticky note or similar between the display and non-glare lens then pulling the notice up/out of the frame.

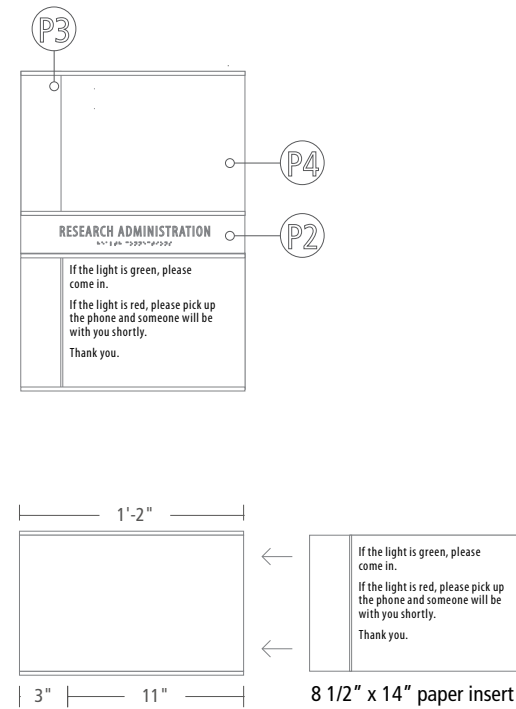

**EXAMPLE LAYOUTS**

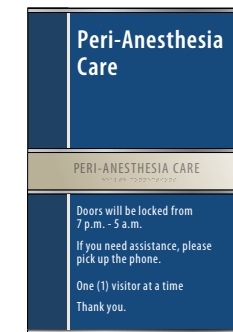
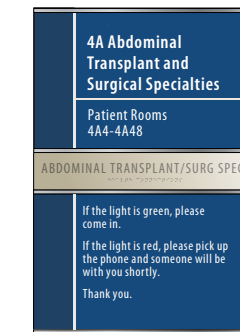

**I-1e PRIMARY ID w/LETTER SIZED INSERT HOLDER**  
Scale: 1"=1'-0" on an 11" x 17" sheet

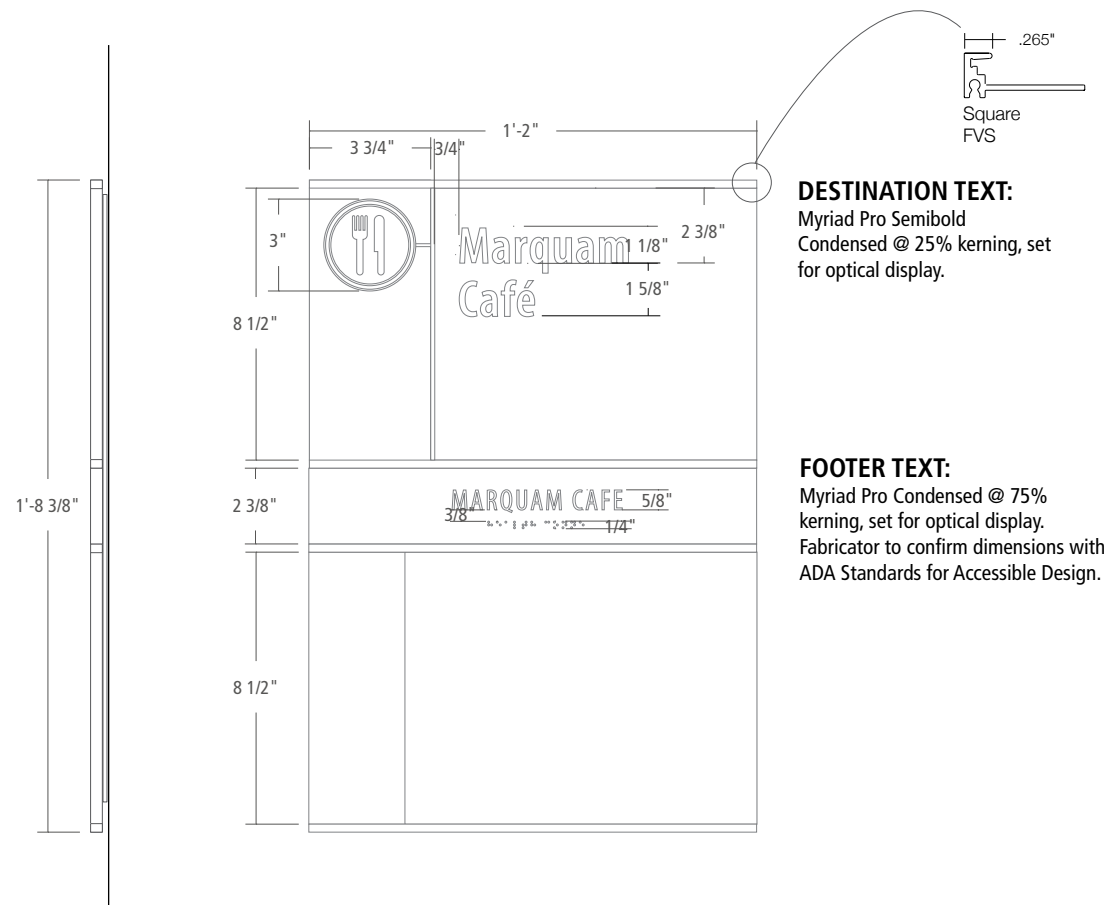

**DESTINATION TEXT:**  
Myriad Pro Semibold  
Condensed @ 25% kerning, set  
for optical display.

**FOOTER TEXT:**  
Myriad Pro Condensed @ 75%  
kerning, set for optical display.  
Fabricator to confirm dimensions with  
ADA Standards for Accessible Design.

**EXAMPLE LAYOUTS**

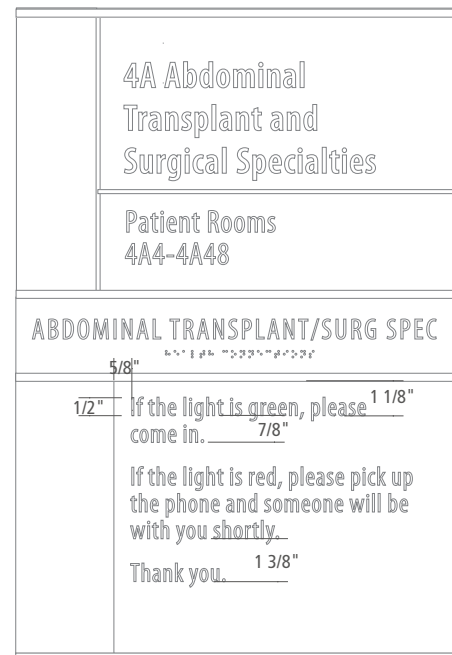

**PATIENT ROOM TEXT:**  
Myriad Pro Condensed @ 25%  
kerning, set for optical display.

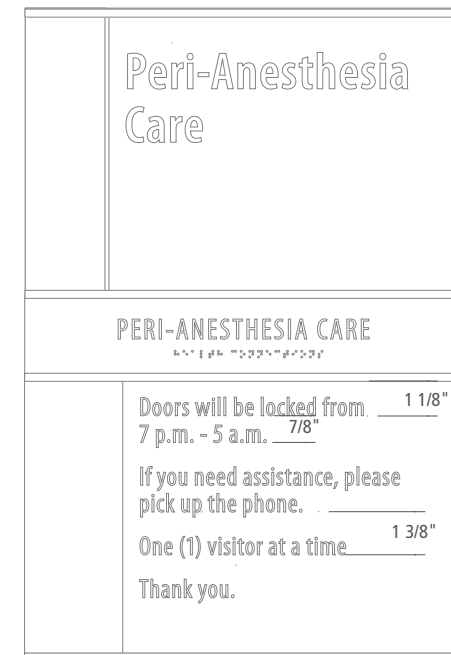

**I-1e PRIMARY ID, w/LETTER SIZED INSERT HOLDER DETAIL**  
SPECIFICATION DETAILS  
Scale: 2"=1'-0"

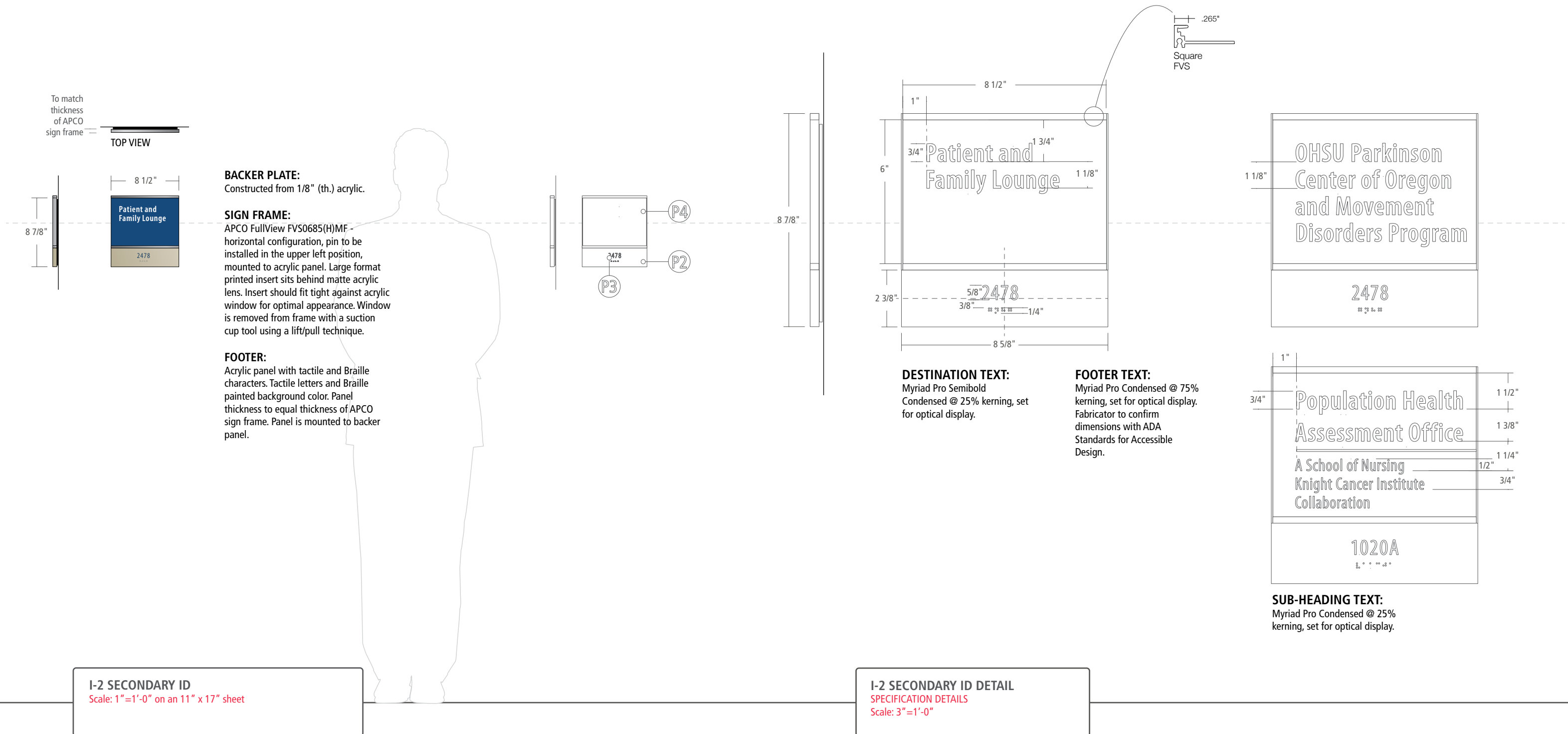

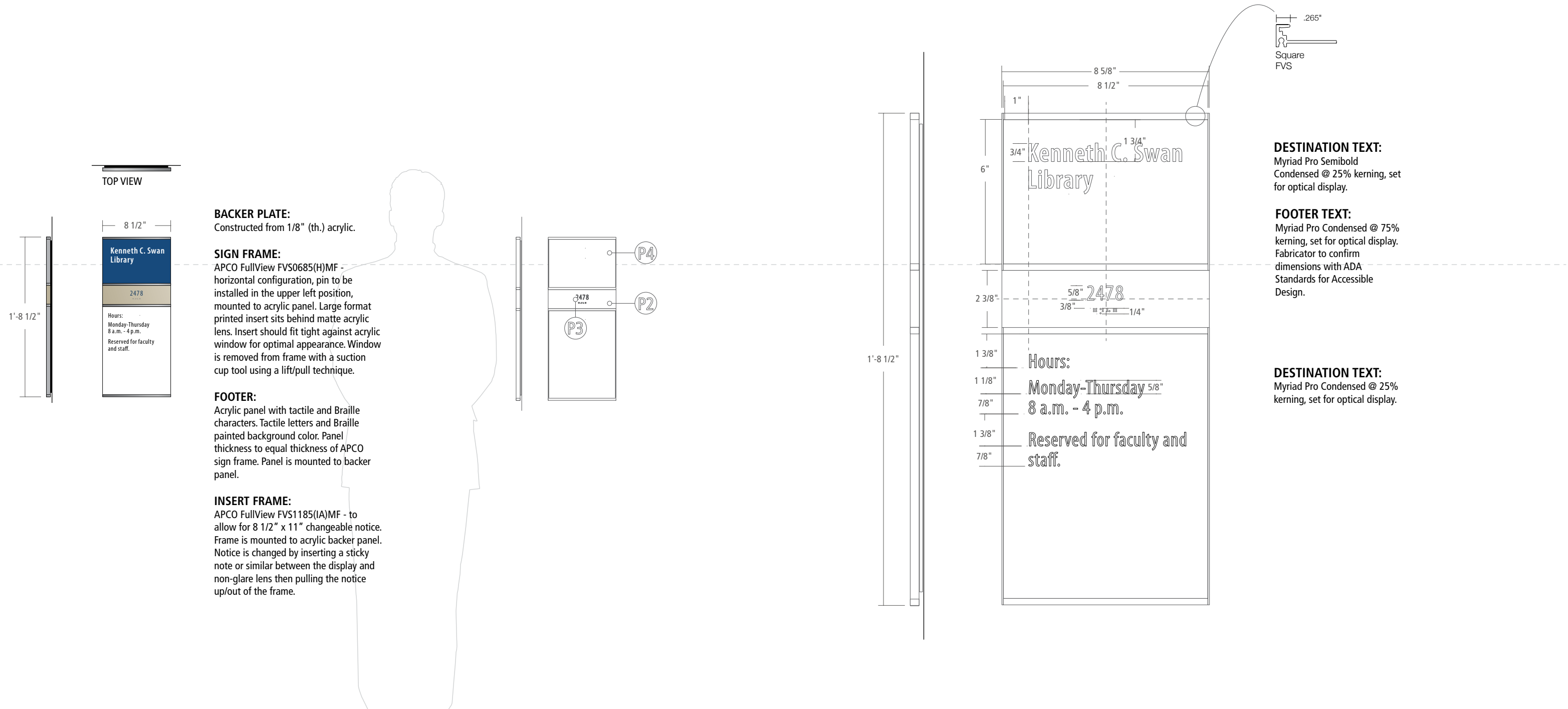

**BACKER PLATE:**  
Constructed from 1/8" (th.) acrylic.

**SIGN FRAME:**  
APCO FullView FVS0685(H)MF - horizontal configuration, pin to be installed in the upper left position, mounted to acrylic panel. Large format printed insert sits behind matte acrylic lens. Insert should fit tight against acrylic window for optimal appearance. Window is removed from frame with a suction cup tool using a lift/pull technique.

**FOOTER:**  
Acrylic panel with tactile and Braille characters. Tactile letters and Braille painted background color. Panel thickness to equal thickness of APCO sign frame. Panel is mounted to backer panel.

**INSERT FRAME:**  
APCO FullView FVS1185(A)MF - to allow for 8 1/2" x 11" changeable notice. Frame is mounted to acrylic backer panel. Notice is changed by inserting a sticky note or similar between the display and non-glare lens then pulling the notice up/out of the frame.

**DESTINATION TEXT:**  
Myriad Pro Semibold Condensed @ 25% kerning, set for optical display.

**FOOTER TEXT:**  
Myriad Pro Condensed @ 75% kerning, set for optical display. Fabricator to confirm dimensions with ADA Standards for Accessible Design.

**DESTINATION TEXT:**  
Myriad Pro Condensed @ 25% kerning, set for optical display.

**I-2a CONFERENCE ROOM ID w/INSERT HOLDER**  
Scale: 1"=1'-0" on an 11" x 17" sheet

**I-2a CONFERENCE ROOM ID w/NOTICE HOLDER**  
SPECIFICATION DETAILS  
Scale: 3"=1'-0"

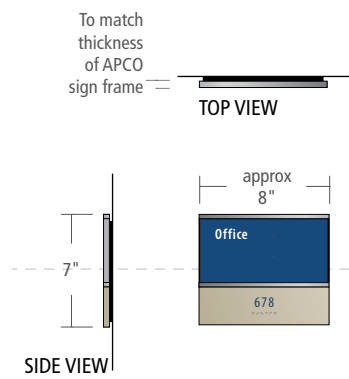

**BACKER PLATE:**

Constructed from 1/8" (th.) acrylic.

**SIGN FRAME:**

APCO FullView FVS0408(H) - horizontal configuration, pin to be installed in the upper left position, mounted to acrylic panel. Large format printed insert sits behind matte acrylic lens. Insert should fit tight against acrylic window for optimal appearance. Window is removed from frame with a suction cup tool using a lift/pull technique.

**FOOTER:**

Acrylic panel with tactile and Braille characters. Tactile letters and Braille painted background color. Panel thickness to equal thickness of APCO sign frame. Panel is mounted to backer panel.

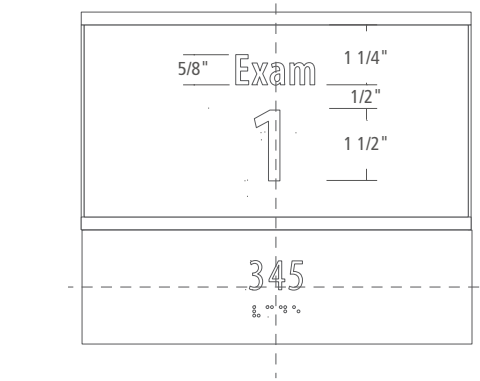
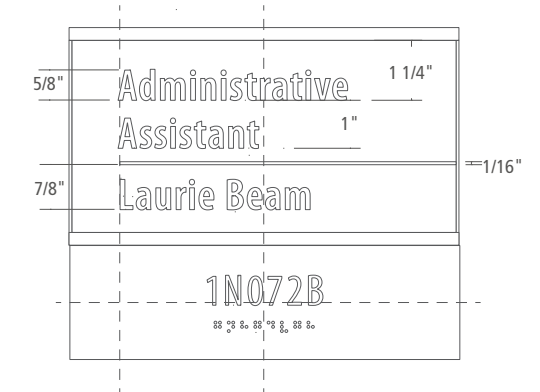
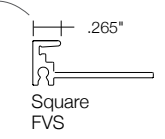
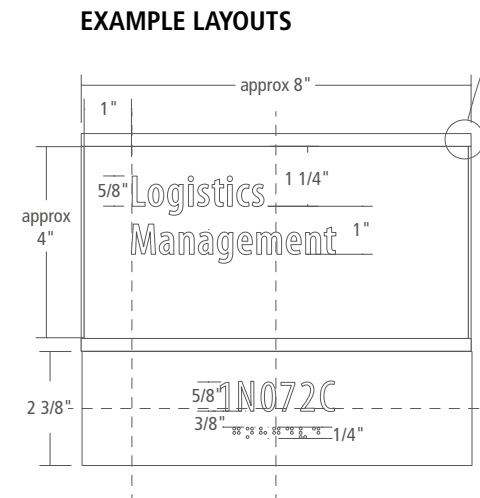
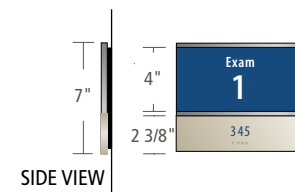
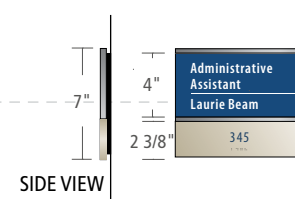
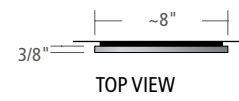
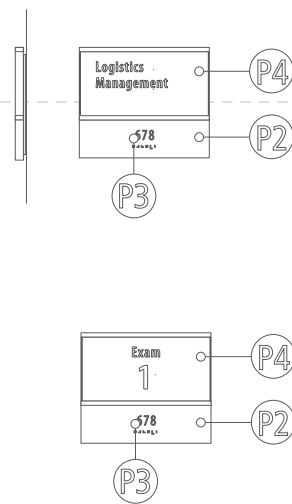
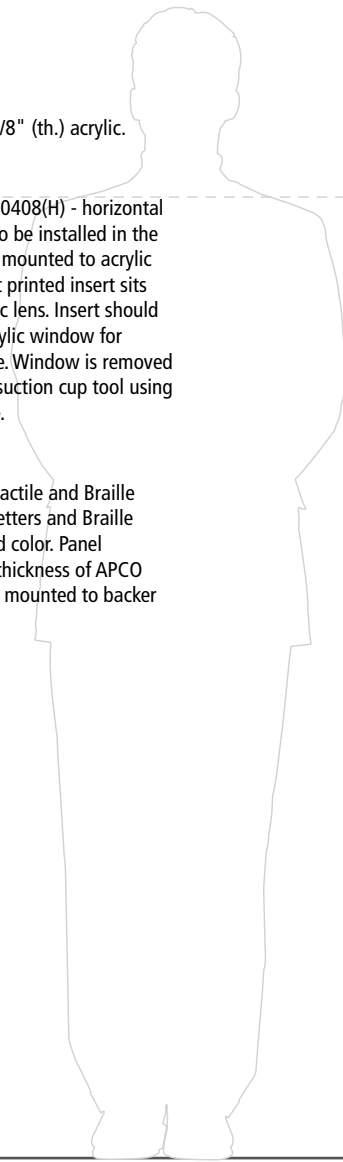

**DESTINATION TEXT:**

Myriad Pro Semibold  
Condensed @ 25% kerning, set for optical display.

**FOOTER TEXT:**

Myriad Pro Condensed @ 75% kerning, set for optical display. Fabricator to confirm dimensions with ADA Standards for Accessible Design.

I-3 GENERAL ROOM ID  
Scale: 1"=1'-0" on an 11" x 17" sheet

I-3 GENERAL ROOM ID  
SPECIFICATION DETAILS  
Scale: 3"=1'-0" on an 11" x 17" sheet

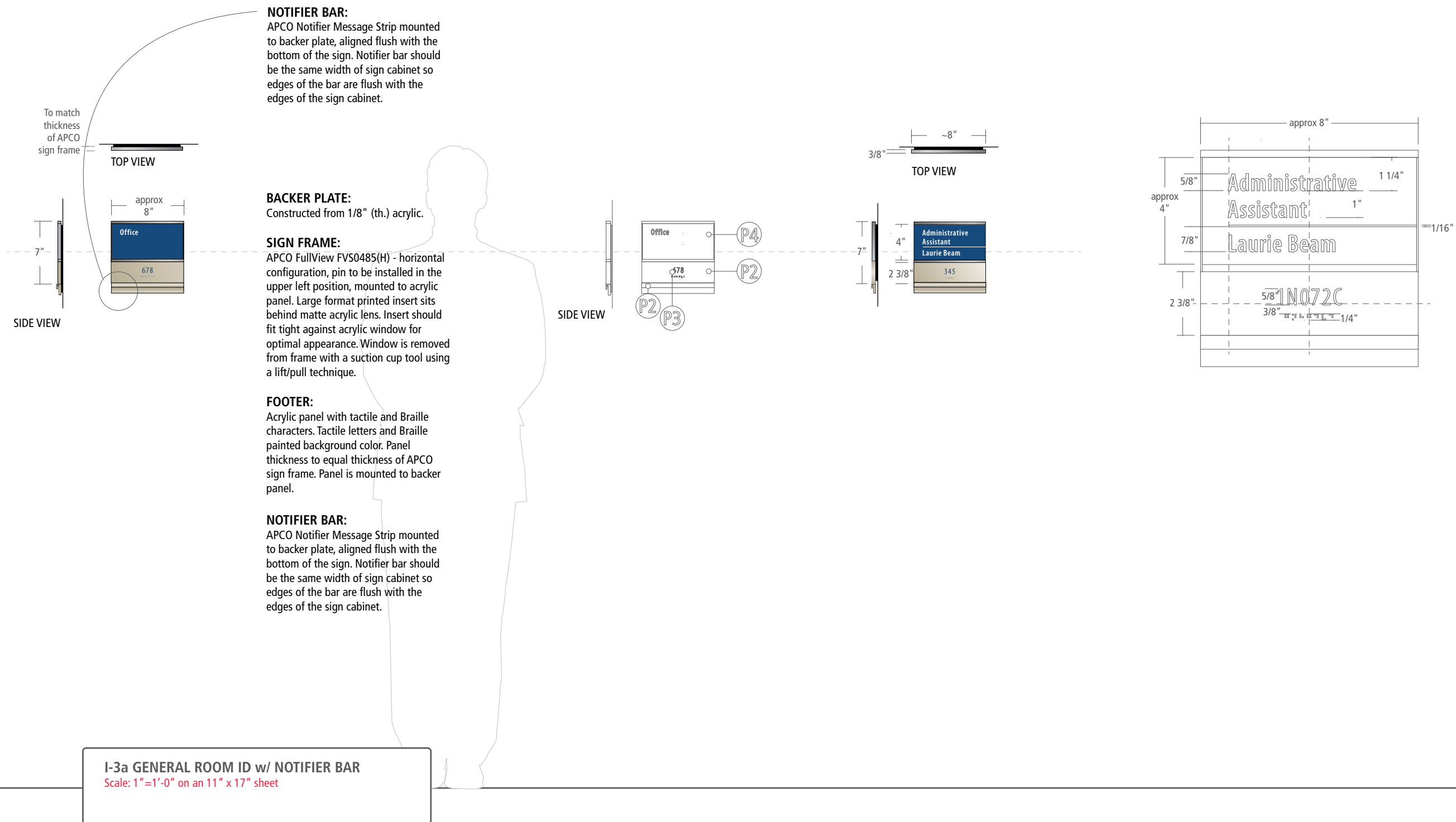

**I-3a GENERAL ROOM ID w/ NOTIFIER BAR**  
Scale: 1"=1'-0" on an 11" x 17" sheet

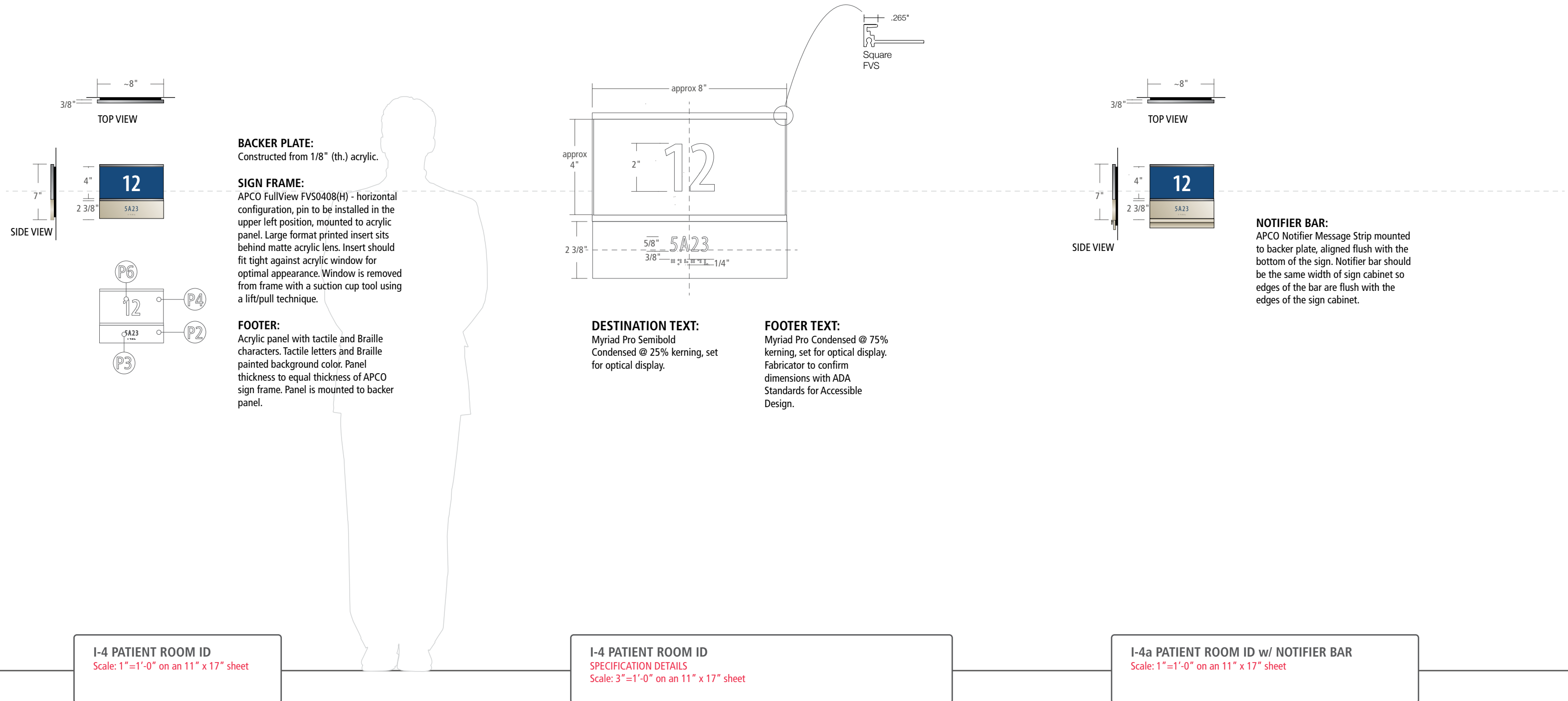

**I-4 PATIENT ROOM ID**  
Scale: 1"=1'-0" on an 11" x 17" sheet

**I-4 PATIENT ROOM ID SPECIFICATION DETAILS**  
Scale: 3"=1'-0" on an 11" x 17" sheet

**I-4a PATIENT ROOM ID w/ NOTIFIER BAR**  
Scale: 1"=1'-0" on an 11" x 17" sheet



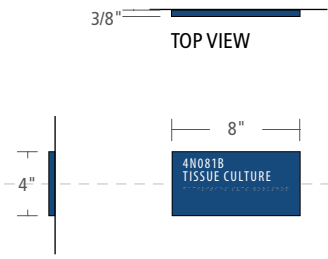

**SIGN PANEL:**  
3/8" thick painted acrylic panel with tactile and Braille characters. Tactile characters painted white.

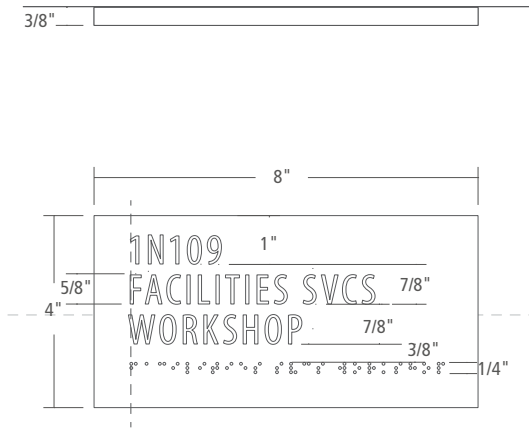
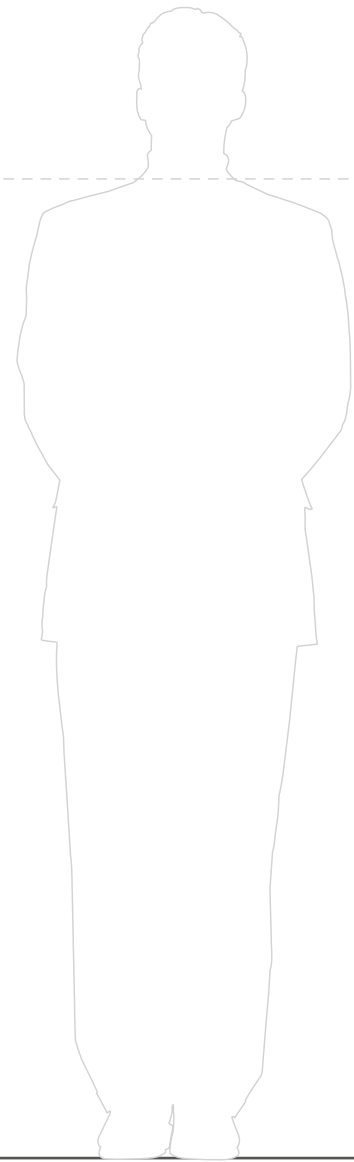

**DESTINATION TEXT:**  
Myriad Pro Condensed, kerning set 75% and optical display.

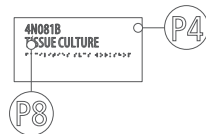

**I-5 UTILITY ID**  
Scale: 1"=1'-0" on an 11" x 17" sheet

**I-5 UTILITY ID**  
SPECIFICATION DETAILS  
Scale: 3"=1'-0" on an 11" x 17" sheet

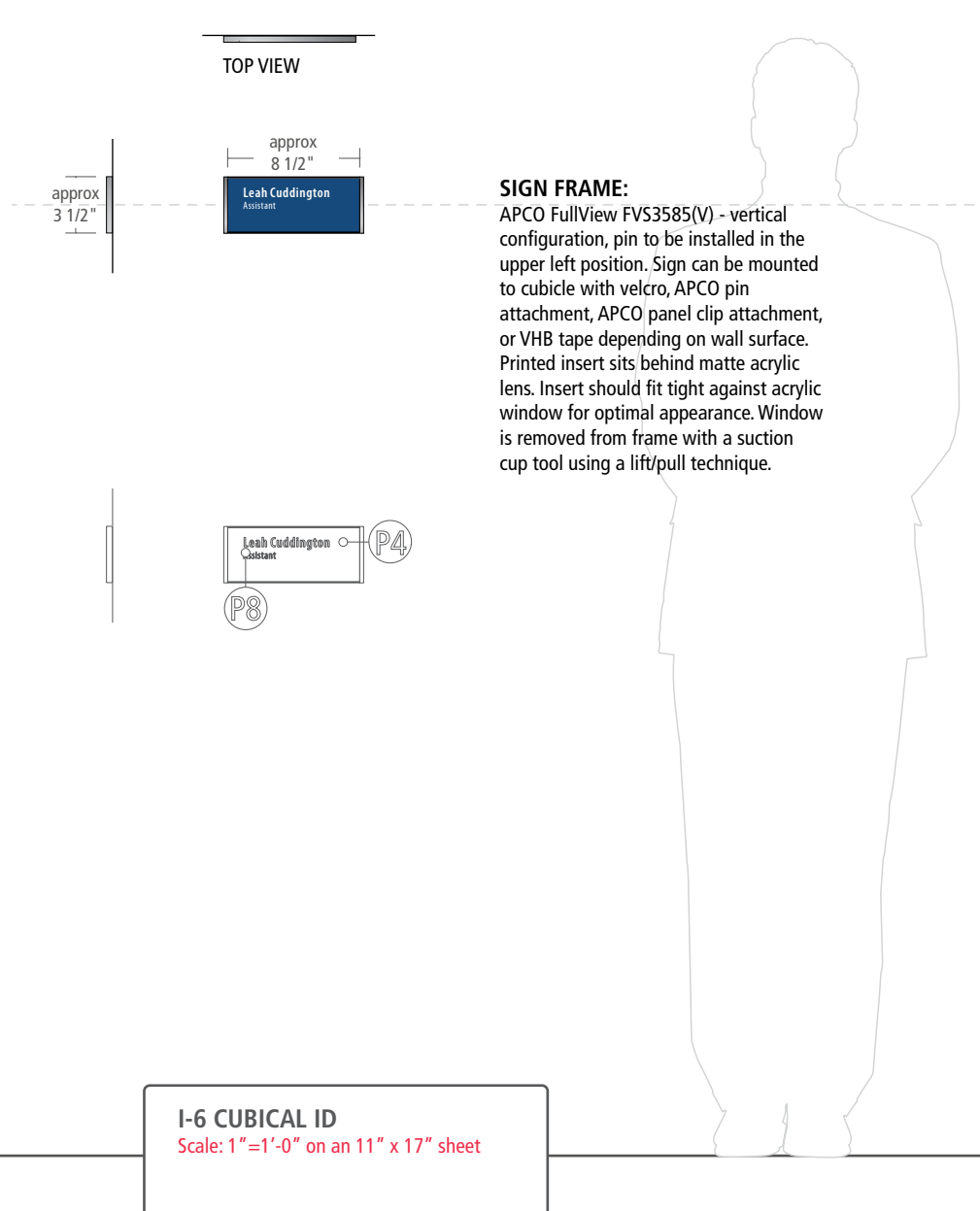

**I-6 CUBICAL ID**  
Scale: 1"=1'-0" on an 11" x 17" sheet

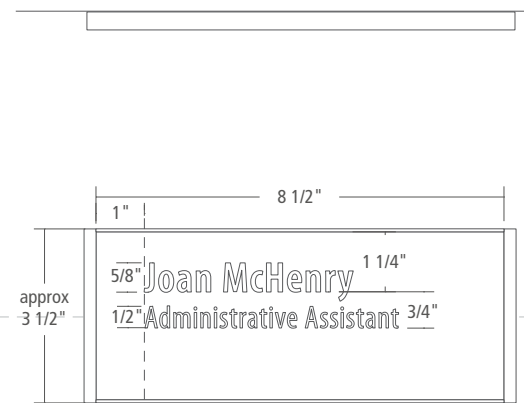

**NAME:**  
Myriad Pro Semibold  
Condensed @ 25% kerning, set  
for optical display.

**TITLE:**  
Myriad Pro Condensed @ 25%  
kerning, set for optical display.

**I-6 CUBICAL ID**  
**SPECIFICATION DETAILS**  
Scale: 3"=1'-0" on an 11" x 17" sheet

**Pin Attachment**  
*For Fabric Mounting*

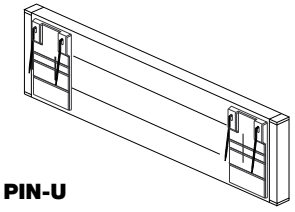

Compatible with the following FullView Standard Assembly, Top Access, Inner Access or E-Series frame sizes:

- 3"h x 6"w
- 3.5"h x 8.5"w
- 4"h x 4"w
- 6"h x 4"w

**PIN-U**

A unique dual-pin feature allows smaller FullView frames to attach to fabric surfaces.

**Panel Clip Attachment**  
*For Office Partitions*

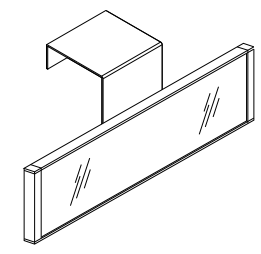

Compatible with the following FullView Standard Assembly, Top Access, Inner Access or E-Series frame sizes:

- 3"h x 6"w
- 3.5"h x 8.5"w
- 4"h x 4"w
- 5.5"h x 8.5"w
- 6"h x 4"w
- 6"h x 6"w

Aluminum clips are custom fabricated to specified dimensions and adhered to the back of the FullView frame.

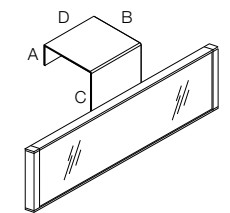

Dimension	Min.	Max.
A	1/2"	1"
B	1"	3"
C (Visible)	0"	3"
D	2"	4"



**INDIVIDUAL LETTERS:**

1/4" thick painted acrylic letters and baseline. Letters and baseline to be cut from same piece of acrylic - no seams. Faces, sides and backs of composition are to be painted. Composition is pin-mounted 3/8" off wall. Pins to be painted to match letters. Fabricator to engineer locations for pins. Owner and fabricator to determine final locations and mounting height.

**FONT:**

Myriad Pro SemiBold Condensed. All capital letters. Text height is stretched to 110%. Kerning set at 100%.

**NOTE:**

Use this sign type only at major public destination desks like Admitting and Information. Not to be used to identify departments or hospital units per directive from Facilities, Hospital Administration, and the Wayfinding Committee.

**I-7 INDIVIDUAL LETTERS, RULE LINE**

Scale: 1 1/4" = 1'-0" on an 11" x 17" sheet  
(unless otherwise noted)

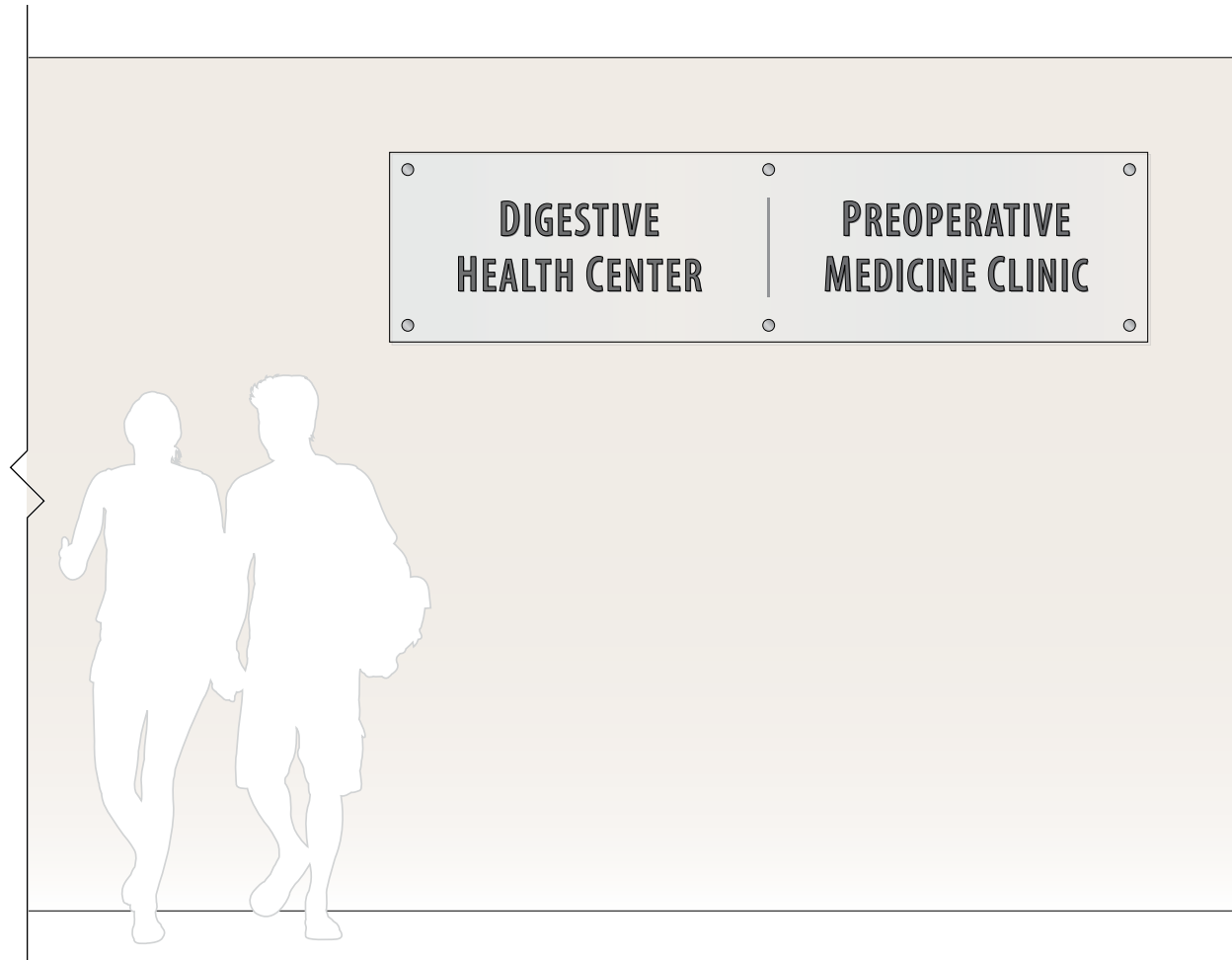

**I-7c INDIVIDUAL LETTERS:**

1/4" thick acrylic letters painted to match dark gray mounted to 1/4" thick frosted acrylic panel, frosted on first surface. Second surface to be painted white (preferred) or covered with white vinyl (acceptable). Faces, sides and backs of letters are to be painted. Acrylic panel is mounted to wall with brushed aluminum decorative stand-off museum mounts. Fabricator to engineer if additional mounts are necessary. Owner and fabricator to determine final dimensions and mounting height.

**FONT:**

Myriad Pro SemiBold Condensed. All capital letters. Vertical Scale is set to 110% and tracking is set to 50. Initial letter has a 4-3/8" cap height, subsequent letters have a 4-0" cap height.

**STANDARD LAYOUT:**



**ALTERNATE LAYOUT:**



(SO1625AL) 5/8" x 1" Through Grip Standoffs, Round, Aluminum, Silver

**I-7c INDIVIDUAL LETTERS, ACRYLIC PANEL**  
 Scale: 1/2" = 1'-0" on an 11" x 17" sheet  
 (unless otherwise noted)

ALTERNATE LAYOUT:

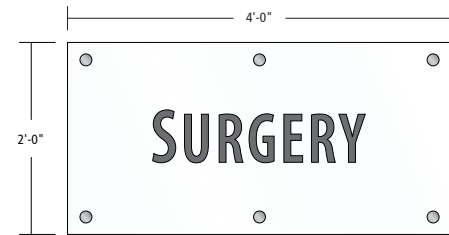

STANDARD LAYOUT:

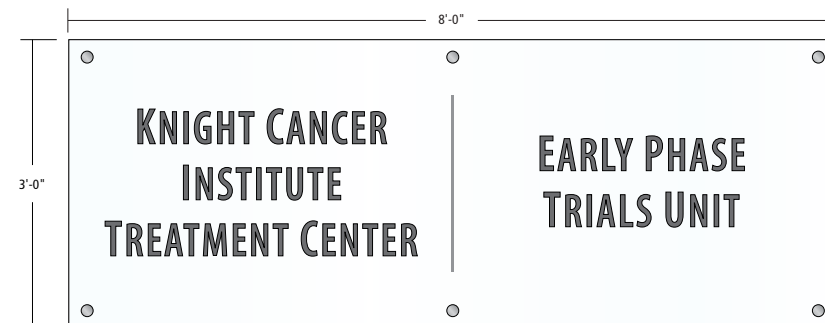
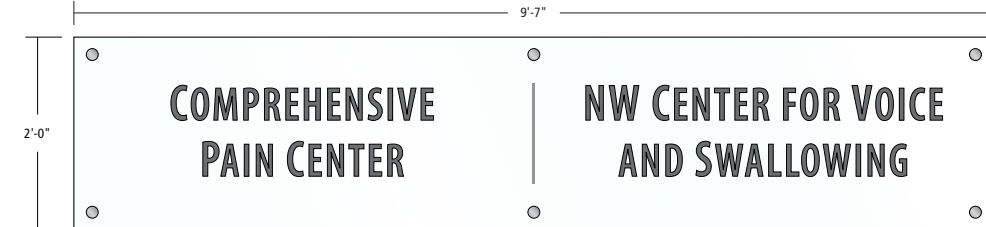
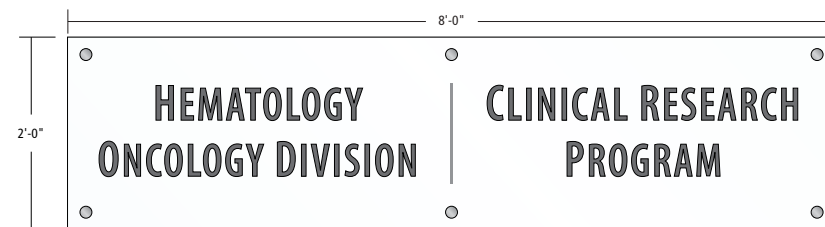
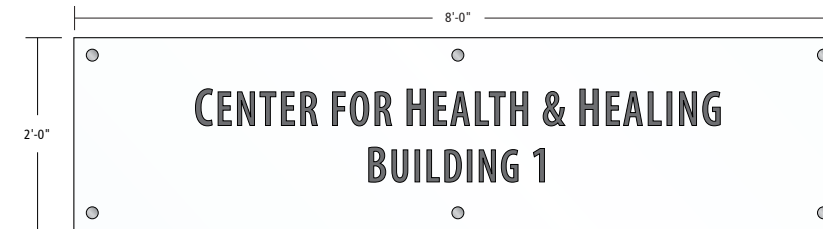
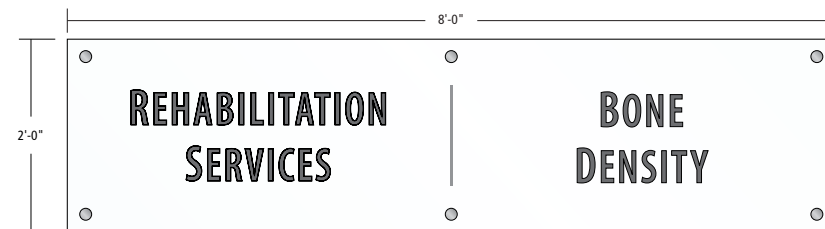
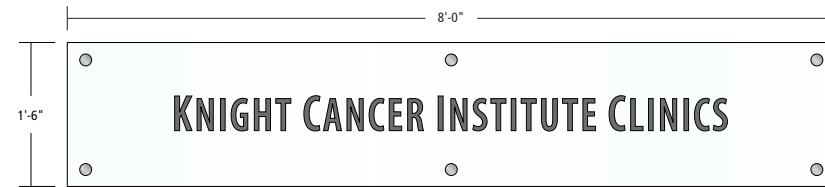
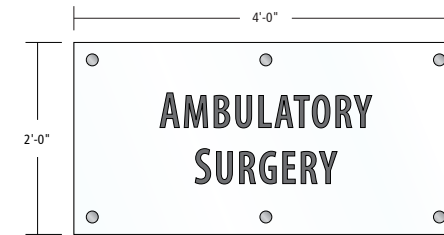
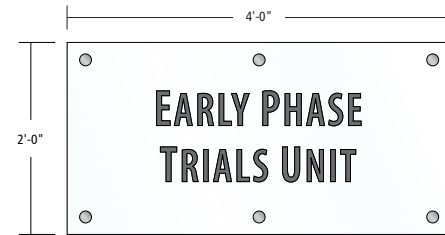

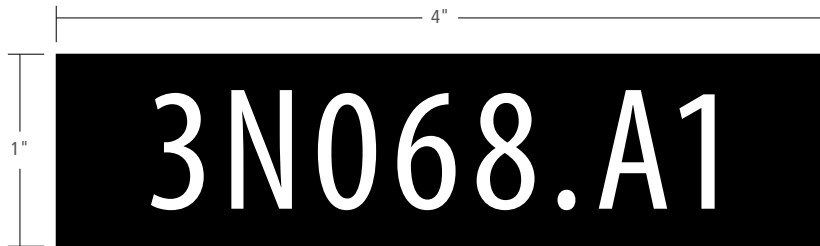

**SIGN PANEL:**  
1/8" thick matte acrylic panel with sub-surface paint and vinyl graphics.

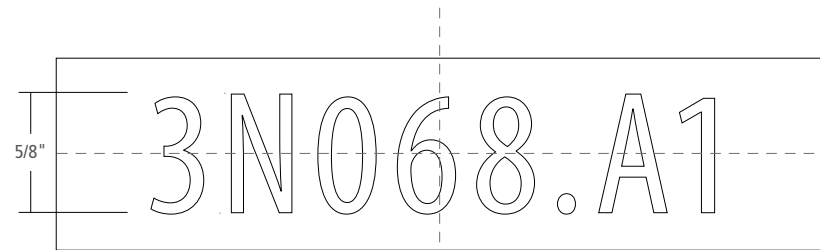

**DESTINATION TEXT:**  
Myriad Pro Condensed, kerning set 75% and optical display.

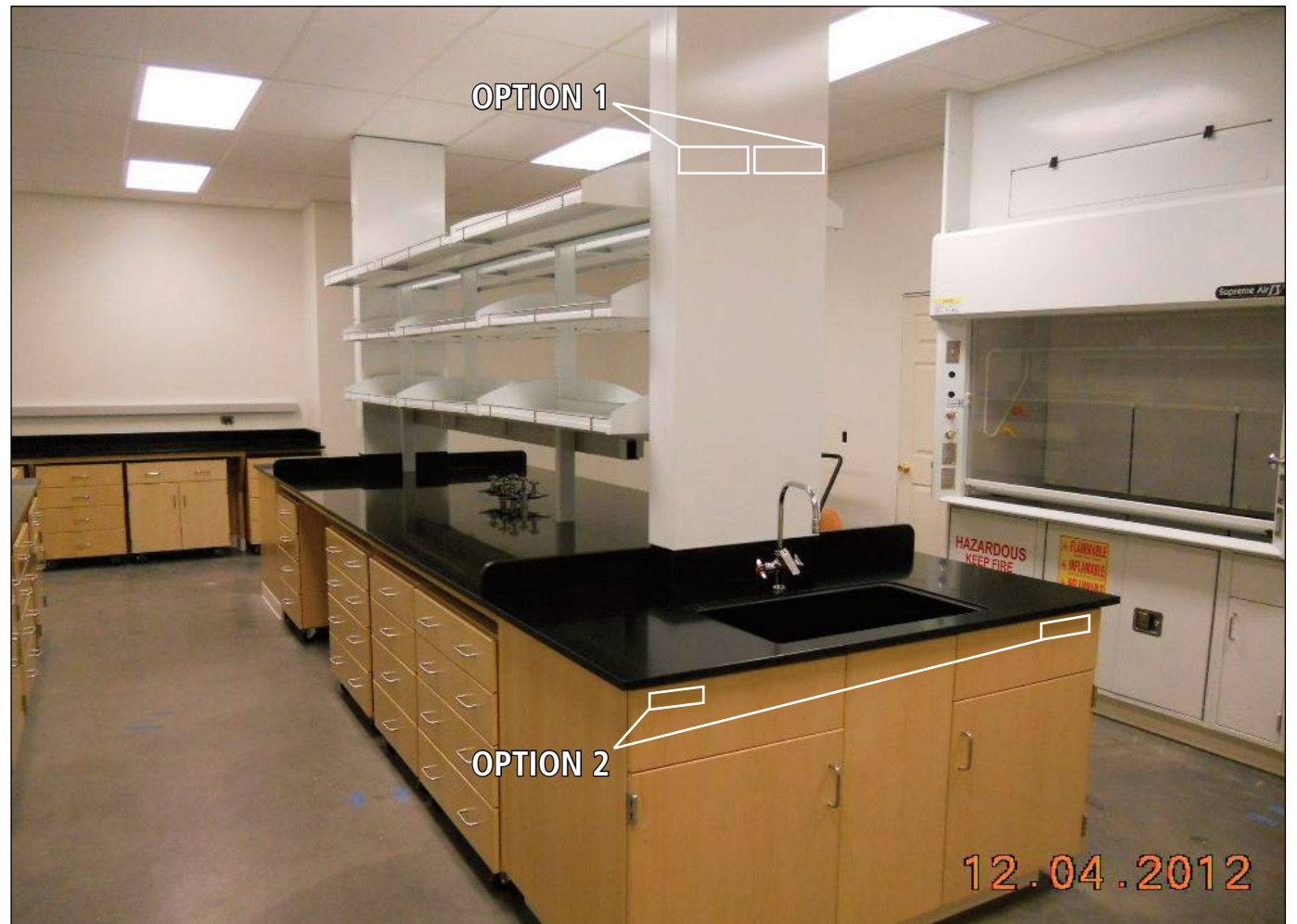

**MOUNTING OPTIONS**

**I-9 RESEARCH BAY IDENTIFIER**  
Scale: 1" = 1" on an 11" x 17" sheet

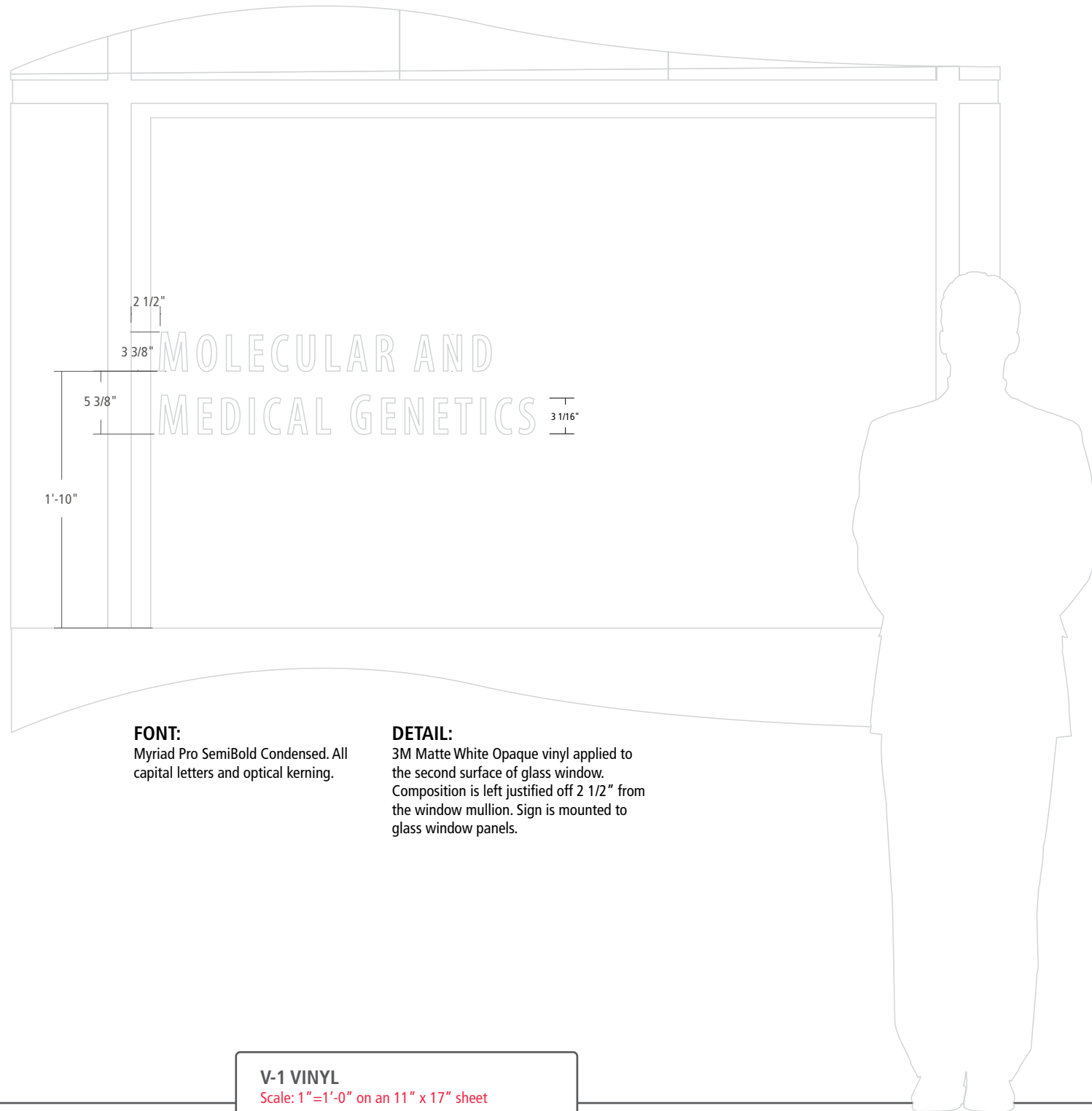

**FONT:**  
Myriad Pro SemiBold Condensed. All capital letters and optical kerning.

**DETAIL:**  
3M Matte White Opaque vinyl applied to the second surface of glass window. Composition is left justified off 2 1/2" from the window mullion. Sign is mounted to glass window panels.

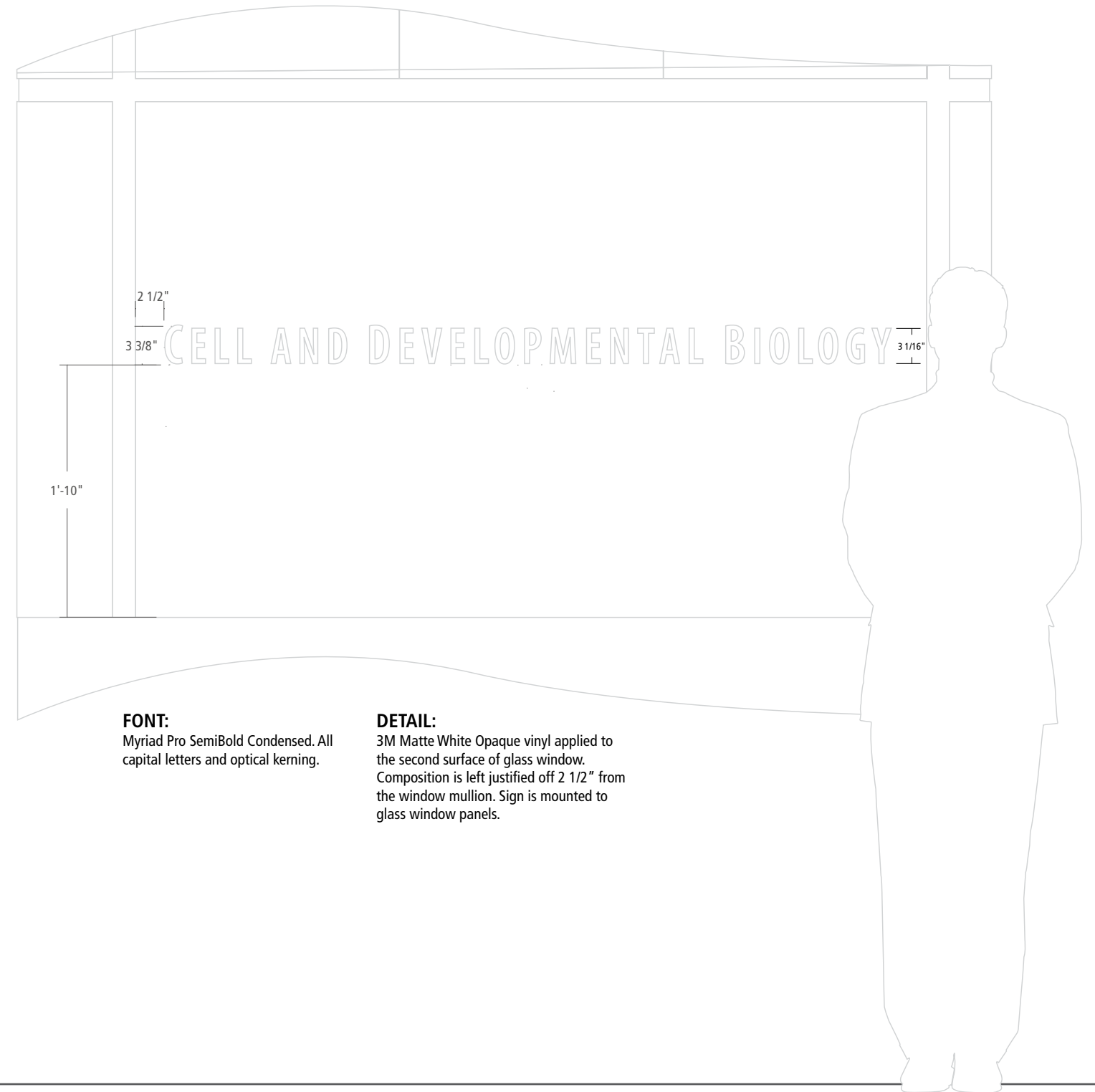

**FONT:**  
Myriad Pro SemiBold Condensed. All capital letters and optical kerning.

**DETAIL:**  
3M Matte White Opaque vinyl applied to the second surface of glass window. Composition is left justified off 2 1/2" from the window mullion. Sign is mounted to glass window panels.

**V-1 VINYL**  
Scale: 1"=1'-0" on an 11" x 17" sheet

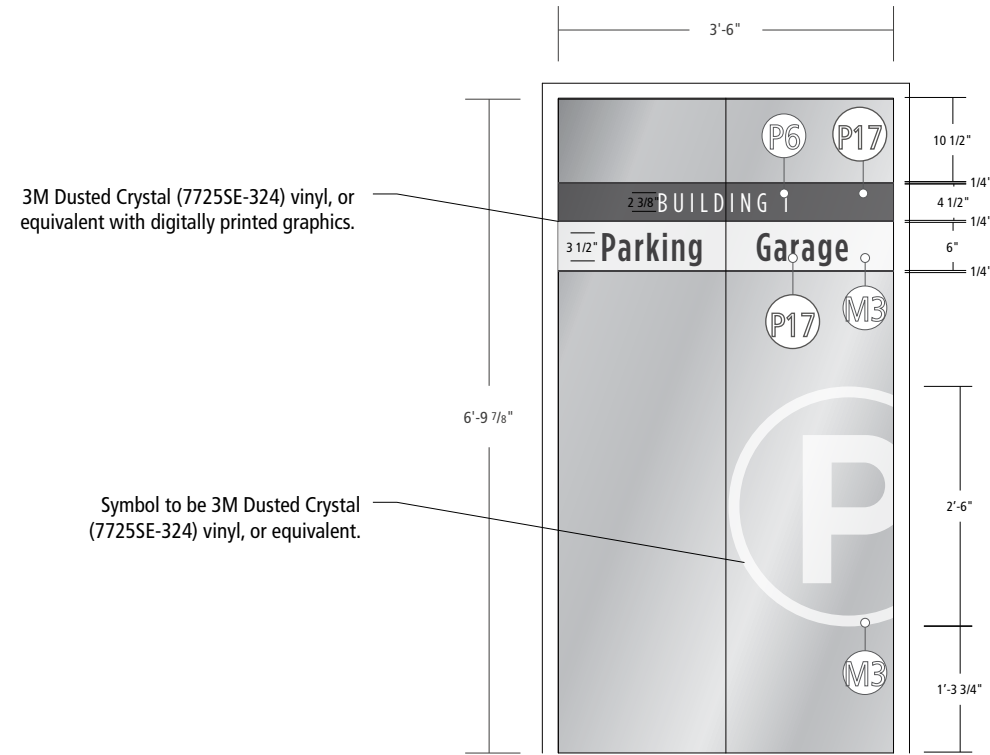

**"BUILDING 1"**  
Font: Gotham Condensed Book, in all caps, with tracking set at 200.

**"Parking Garage"**  
Font: Gotham Condensed Book, in upper and lower case, with tracking set at 50.

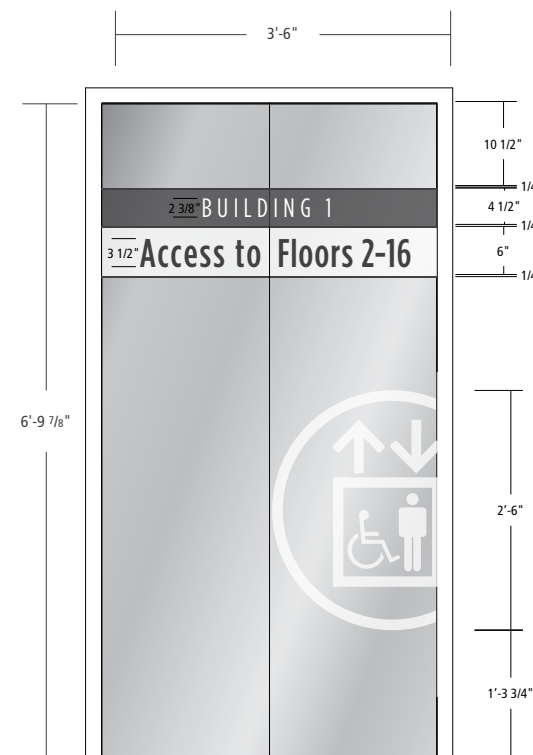
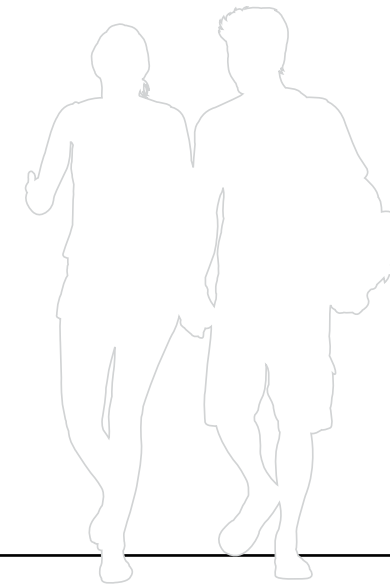

**ALTERNATE LAYOUT:**  
**"BUILDING 1"**  
Font: Gotham Condensed Book, in all caps, with tracking set at 200.

**"Access to Floors 2-16"**  
Font: Gotham Condensed Book, in upper and lower case, with tracking set at 50.

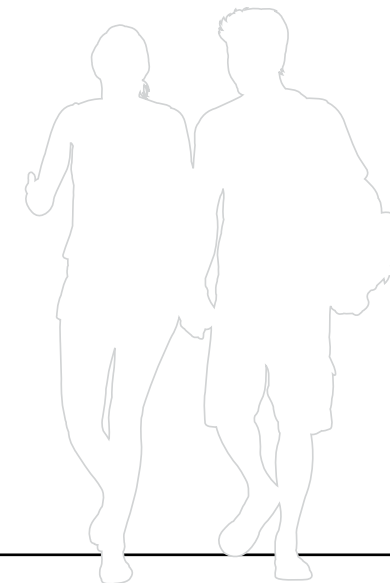

**V-3 VINYL ON ELEVATOR DOOR**  
Scale: 1/2" = 1'-0" on an 11" x 17" sheet



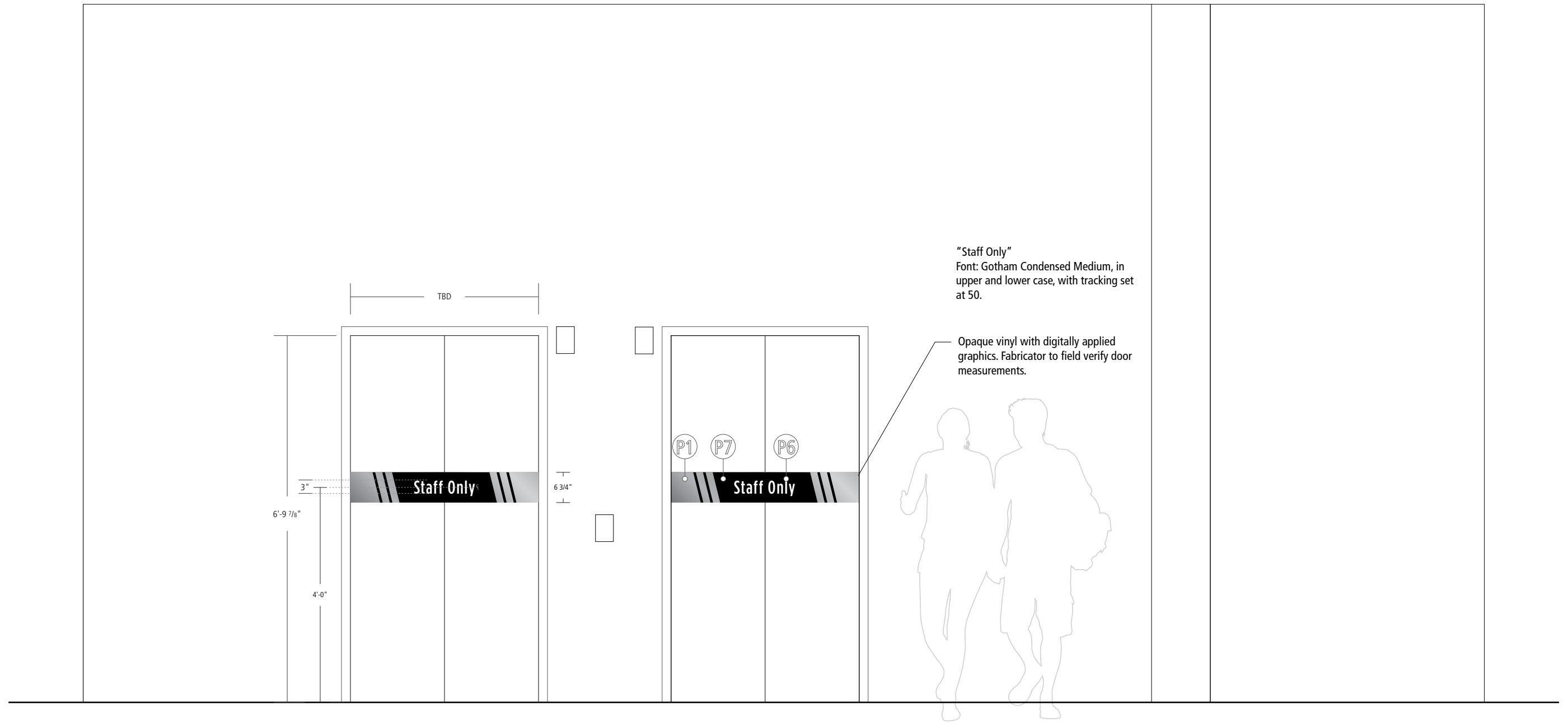

**V-4 VINYL ON STAFF ELEVATOR DOOR**  
Scale: 1/2"=1'-0" on an 11" x 17" sheet

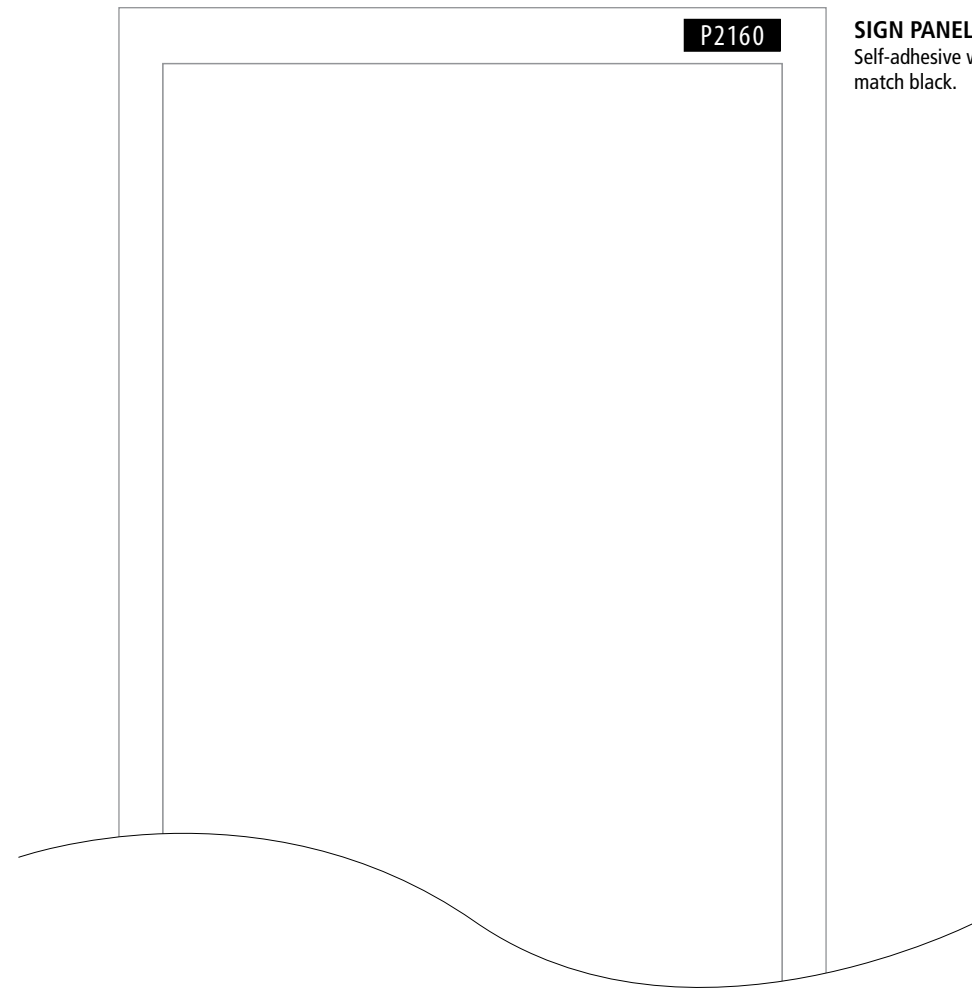

P2160

**SIGN PANEL:**  
Self-adhesive white vinyl digitally printed to match black.

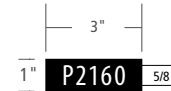

**DESTINATION TEXT:**  
Myriad Pro Condensed, kerning set 75% and optical display.

V-5 DOOR VINYL  
Scale: 1/2" = 1'-0" on an 11" x 17" sheet

## NOTIFIERS

**NOTE:**  
If sign requires easy removal of the printed insert a sign frame with a thumb slot can be specified.

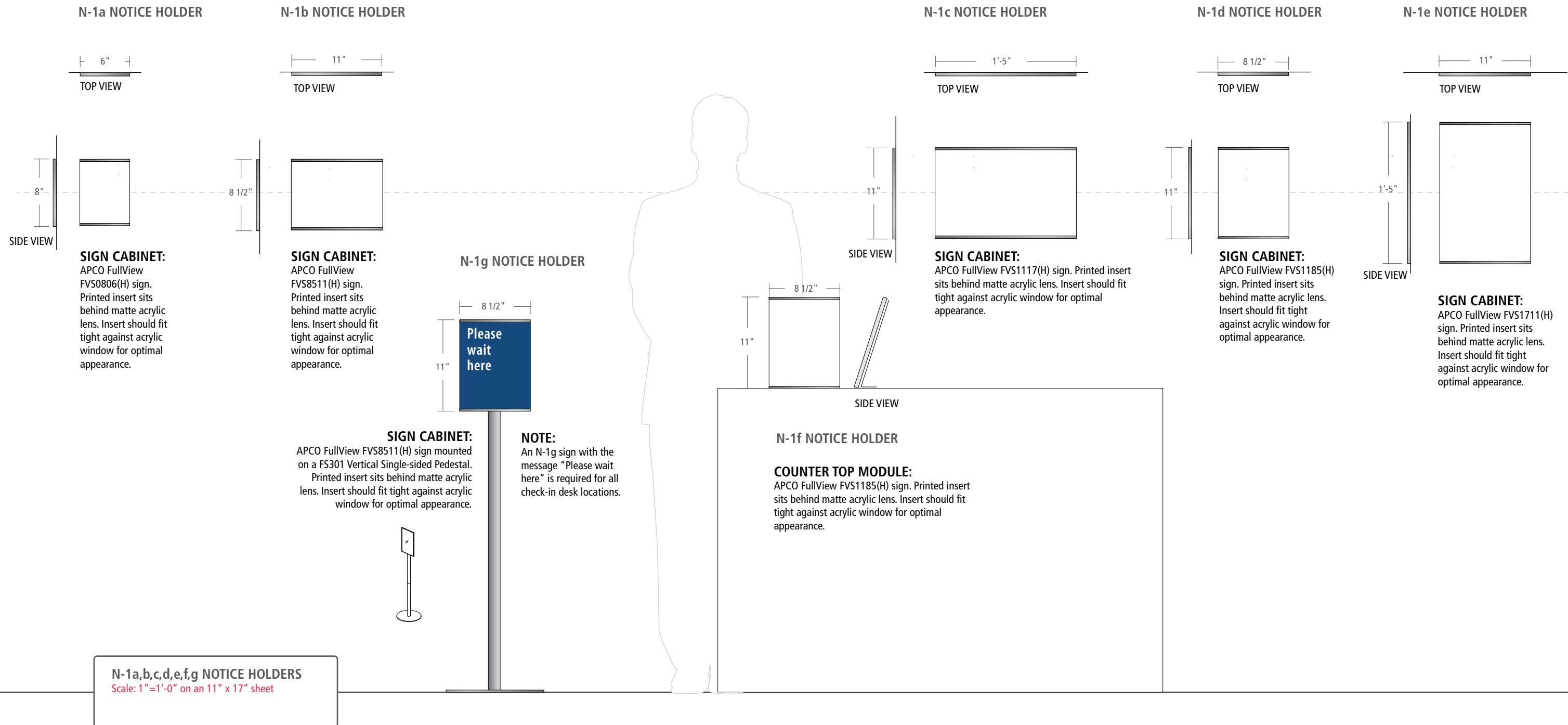

EXAMPLE LAYOUTS

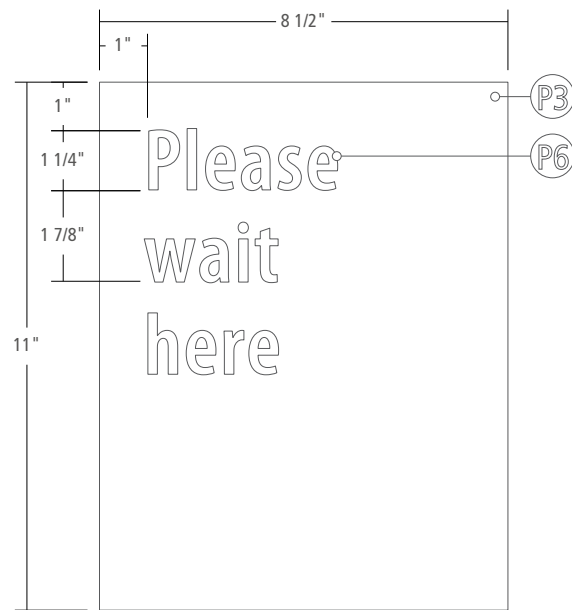

**FONT:**  
 Myriad Pro Semibold  
 Condensed @ 25% kerning, set  
 for optical display.

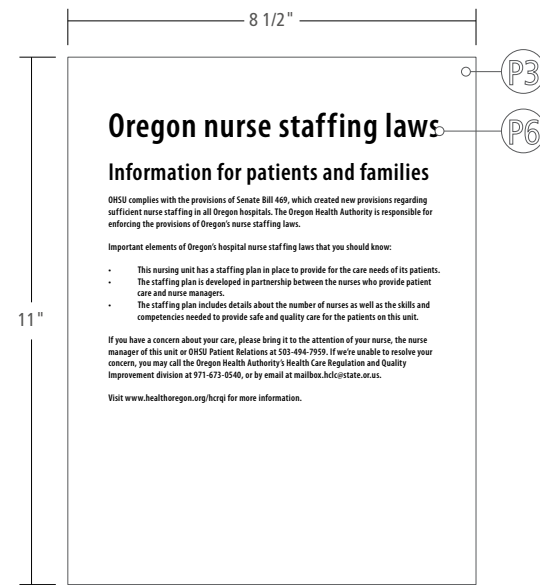

**FONT:**  
 Typeset as shown.

**N-1 GENERAL NOTICE HOLDER DETAILS**  
 Scale: 3" = 1'-0" on an 11" x 17" sheet

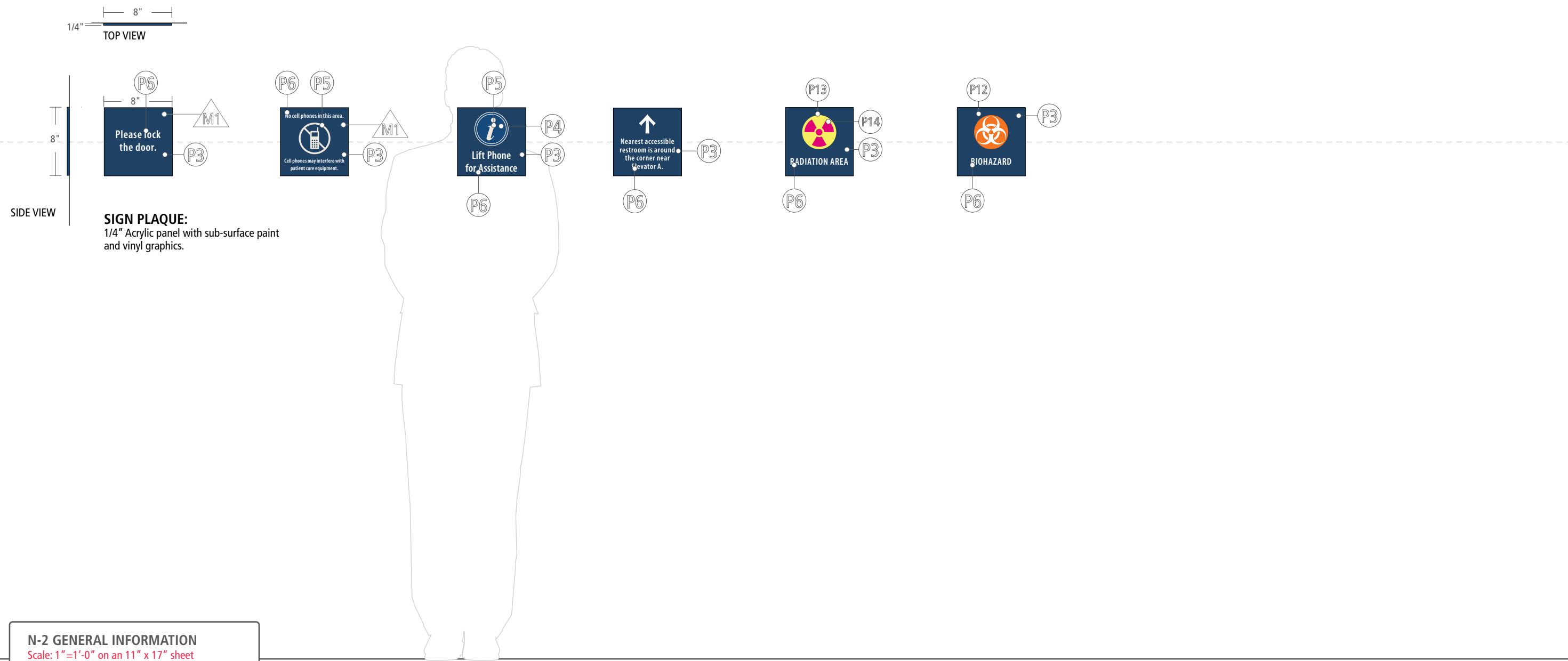

**N-2 GENERAL INFORMATION**  
Scale: 1"=1'-0" on an 11" x 17" sheet

EXAMPLE LAYOUTS

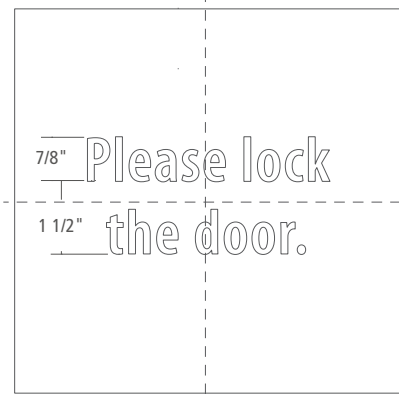

**FONT:**  
 Myriad Pro Semibold  
 Condensed @ 25% kerning, set  
 for optical display.

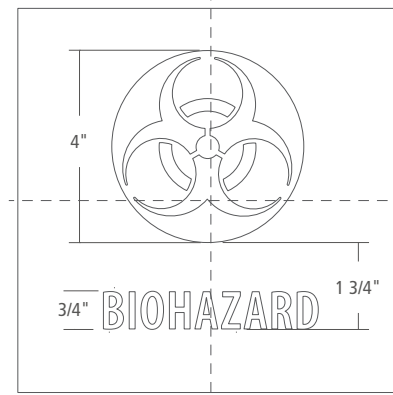
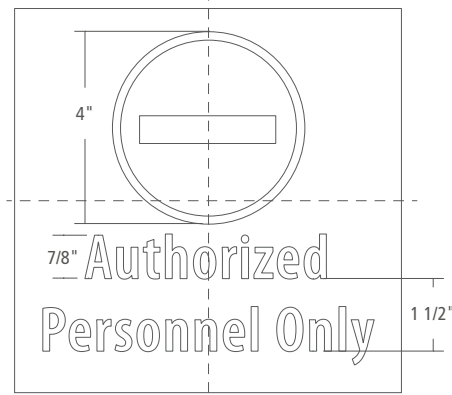
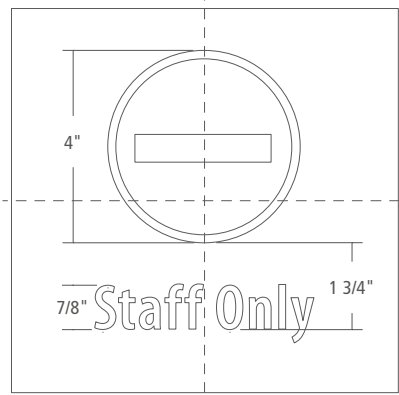
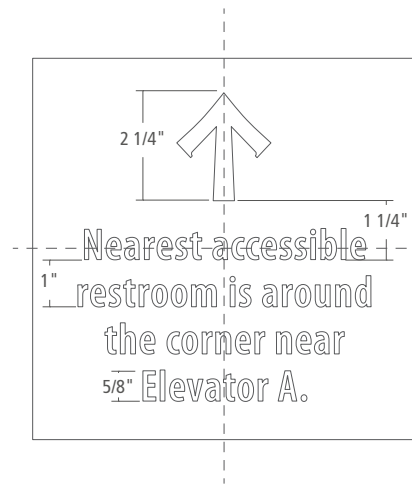
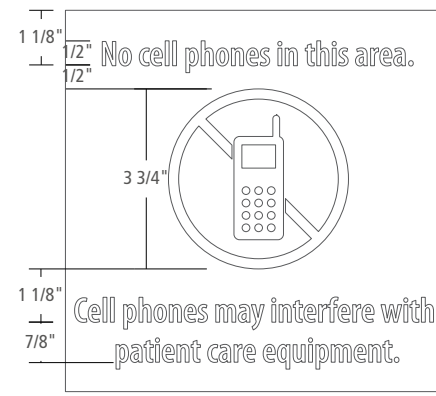
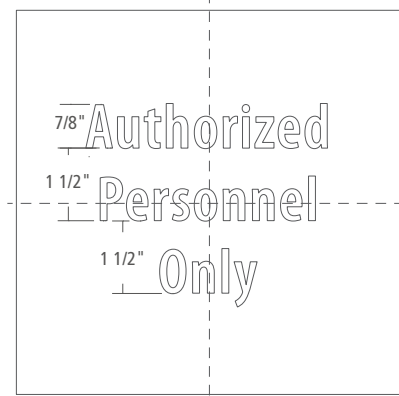
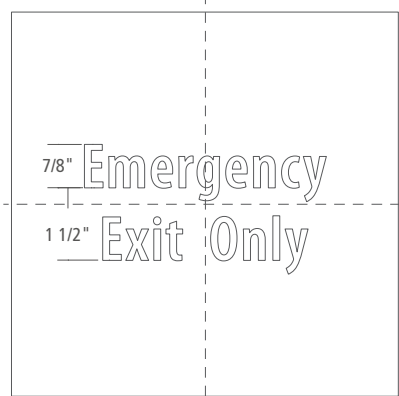

**N-2 GENERAL INFORMATION DETAIL**  
 Scale: 3"=1'-0" on an 11" x 17" sheet

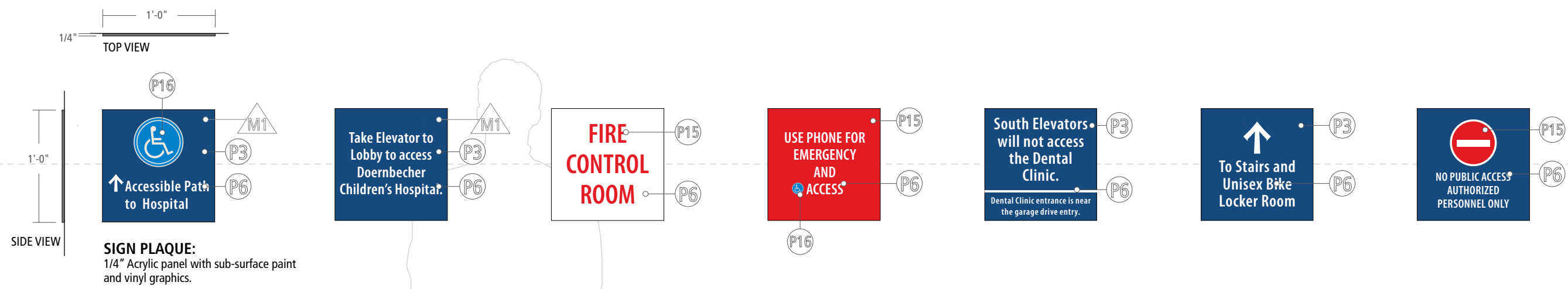

**N-2a GENERAL INFORMATION**  
Scale: 1"=1'-0" on an 11" x 17" sheet



EXAMPLE LAYOUTS

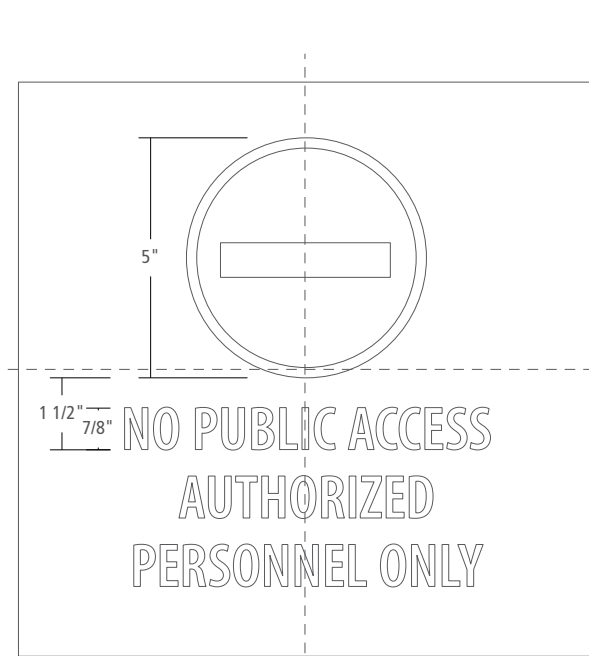
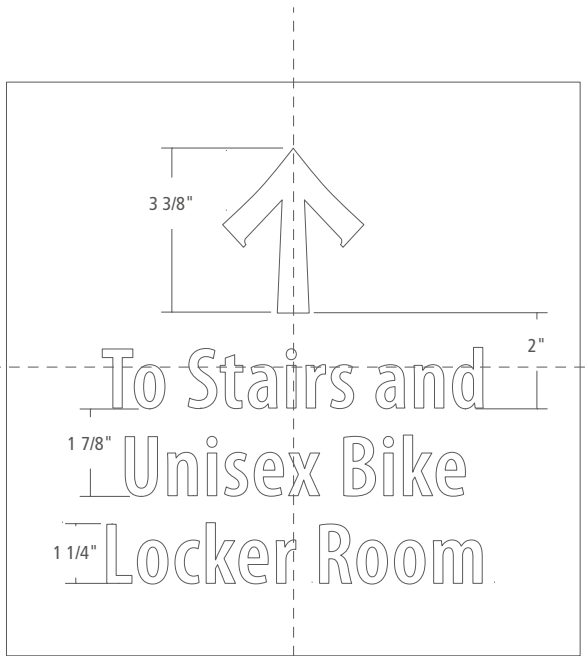
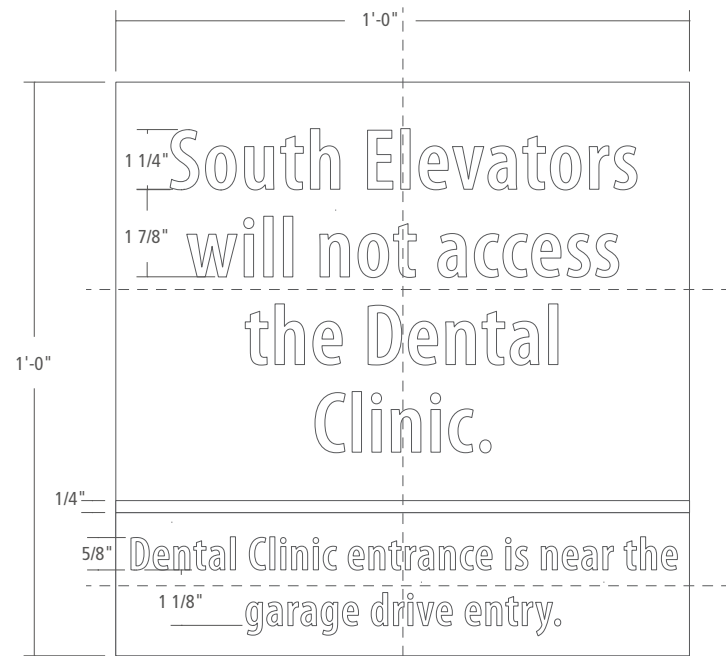
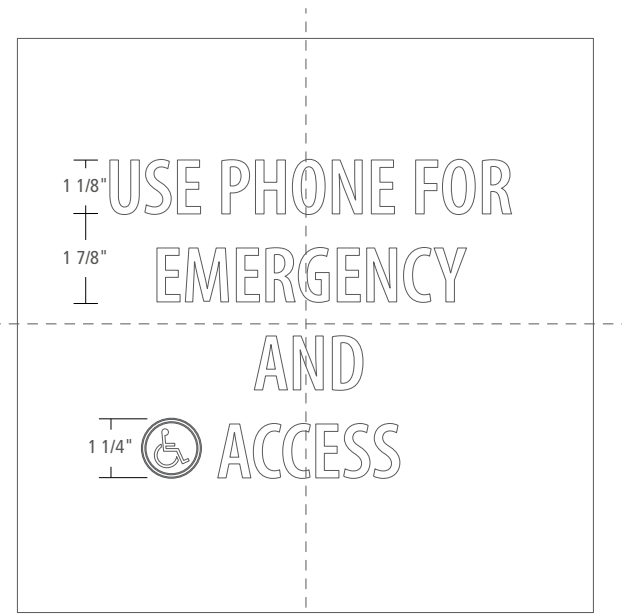
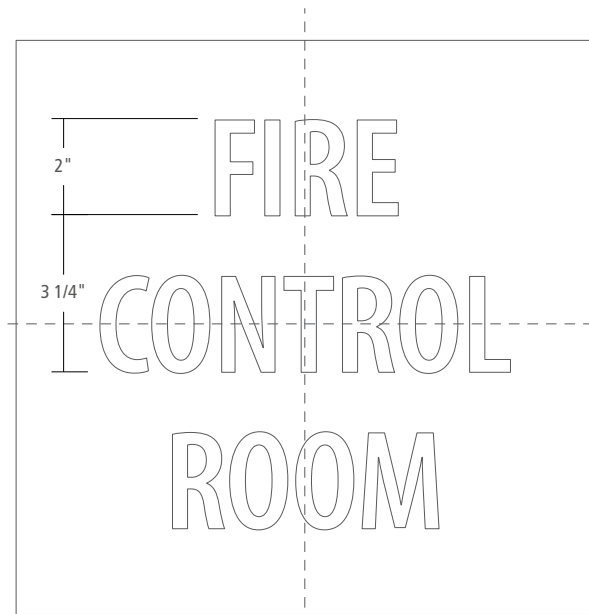
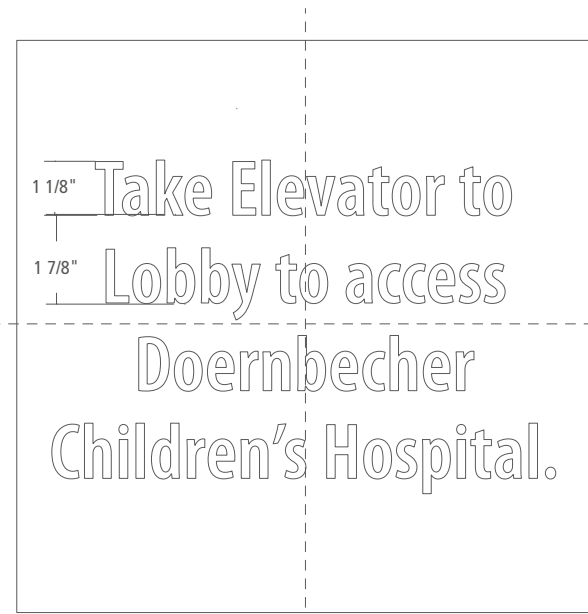

**FONT:**  
 Myriad Pro Semibold  
 Condensed @ 25% kerning, set  
 for optical display.

**N-2a GENERAL INFORMATION DETAIL**  
 Scale: 3"=1'-0" on an 11" x 17" sheet

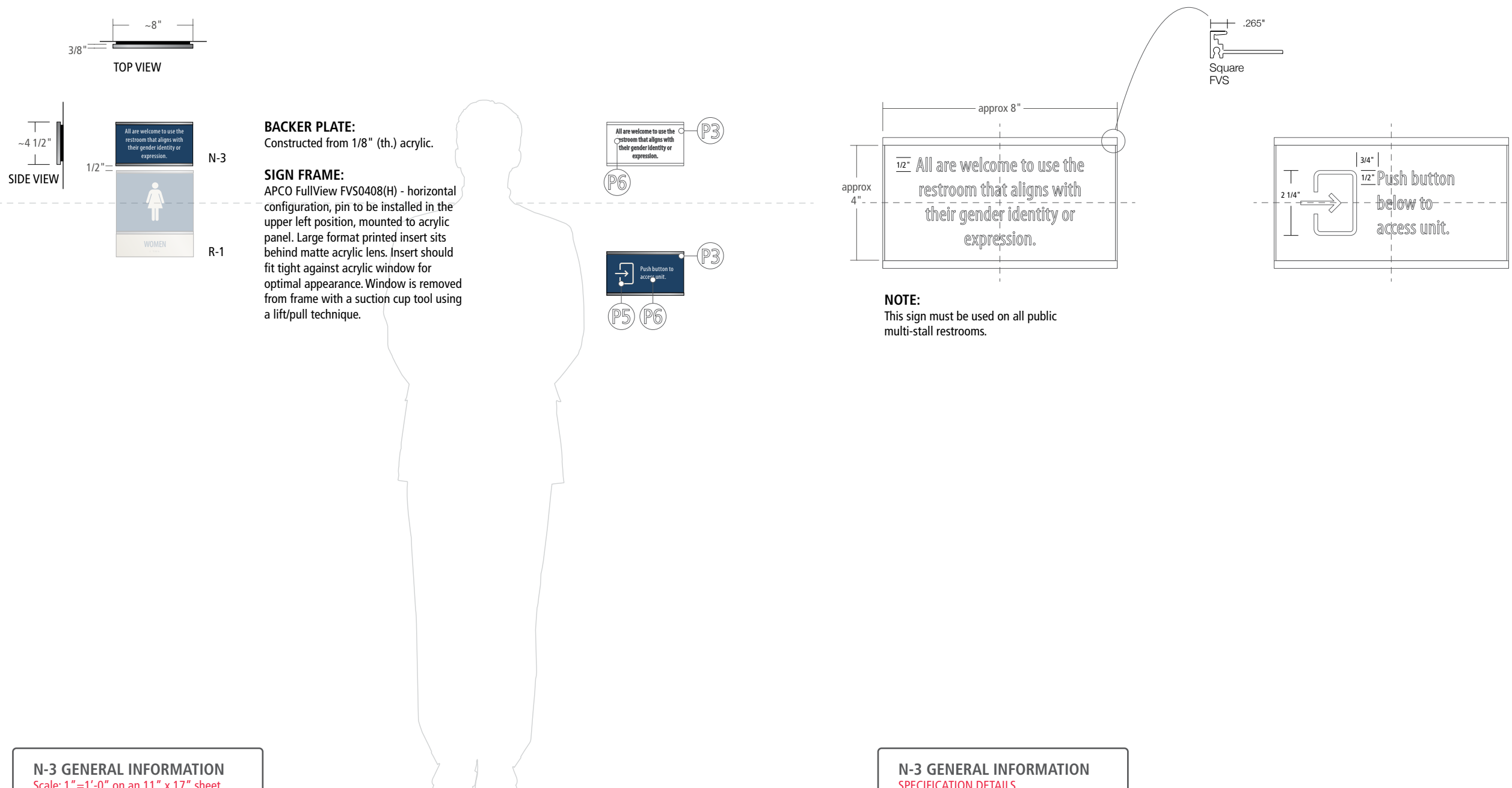

**BACKER PLATE:**  
Constructed from 1/8" (th.) acrylic.

**SIGN FRAME:**  
APCO FullView FVS0408(H) - horizontal configuration, pin to be installed in the upper left position, mounted to acrylic panel. Large format printed insert sits behind matte acrylic lens. Insert should fit tight against acrylic window for optimal appearance. Window is removed from frame with a suction cup tool using a lift/pull technique.

**NOTE:**  
This sign must be used on all public multi-stall restrooms.

**N-3 GENERAL INFORMATION**  
Scale: 1"=1'-0" on an 11" x 17" sheet

**N-3 GENERAL INFORMATION**  
**SPECIFICATION DETAILS**  
Scale: 3"=1'-0" on an 11" x 17" sheet

## REGULATORY

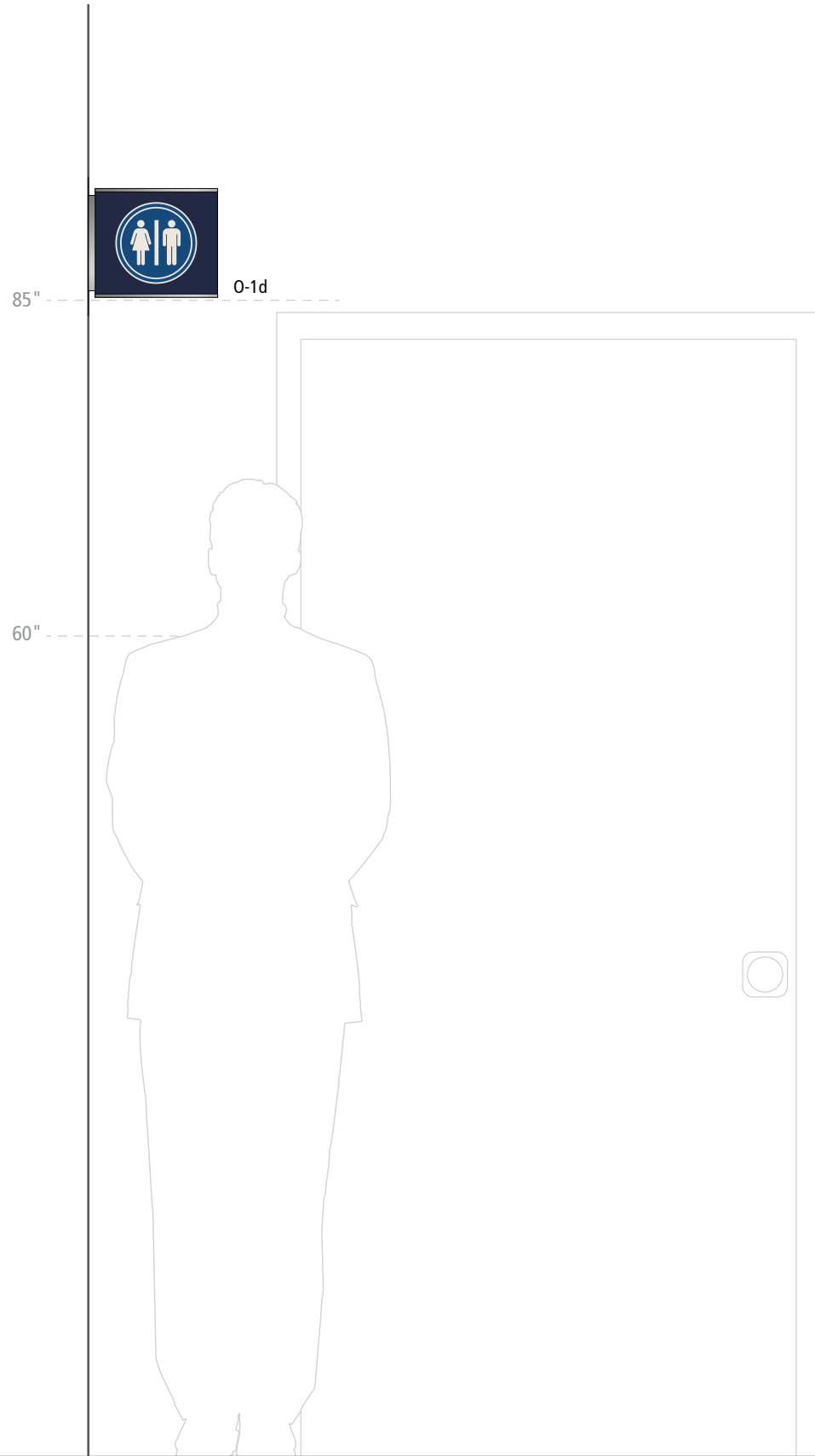

**RESTROOM SIGN STANDARDS:**

- Gender specific, multi-stalled restrooms must include both the R-1/R-1a sign and the N-3 sign above it, as well as directions to the nearest unisex/single-user restroom.
- Add directions to the nearest gender-neutral restroom.
- Unisex/single user restrooms use the R-1/R-1a only.
- Restrooms with changing tables should use the R-1a sign with the correct symbol and "Changing Table Available" message.
- Restrooms that are not accessible must include an N-2.
- Tactile and braille messages:  
 Women's restroom = WOMEN  
 Men's restroom = MEN  
 Patient restroom = RESTROOM  
 Staff restroom = STAFF RESTROOM  
 Unisex/single stall restroom = RESTROOM
- O-1c or O-1d are used at all public restrooms or patient restrooms (when not located within a patient room).
- R-1/R-1a signs use a symbol without the circle.
- O-1c/O-1d flag signs use a symbol with the circle.

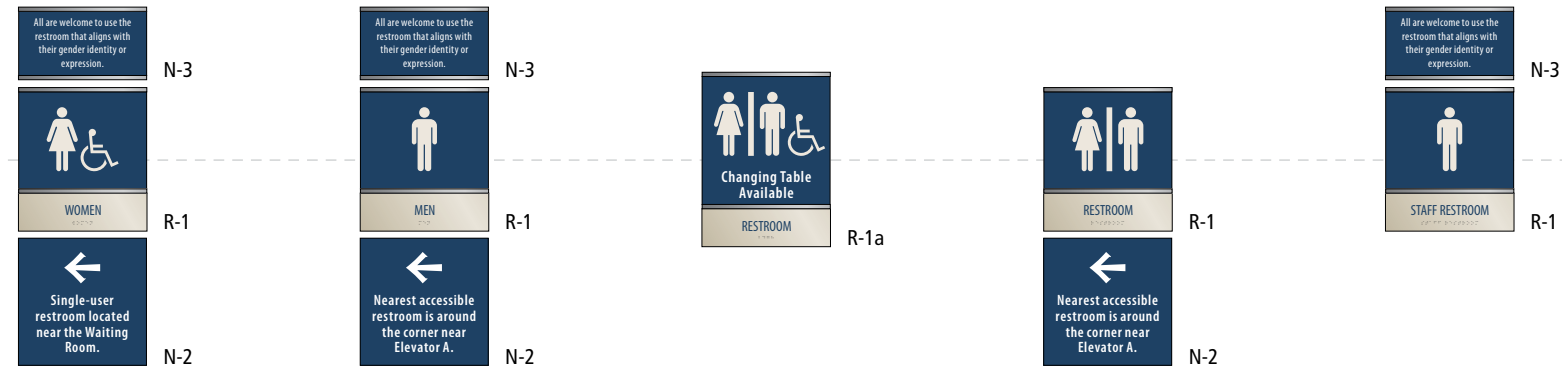

**NOTE:**

All public multi-stall restrooms must also include an N-3 sign with gender neutral statement.

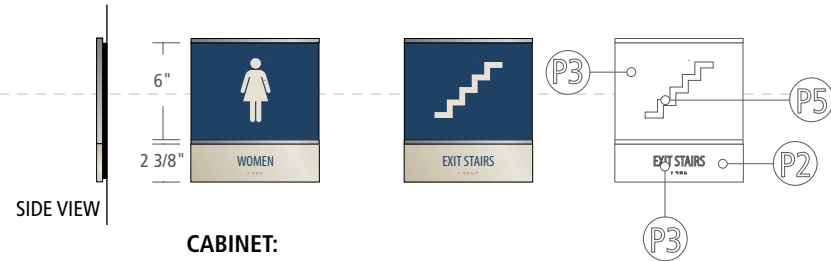
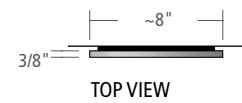

**CABINET:**

APCO FullView Standard Assembly - horizontal configuration, FVS0608(H)MF. Sign frame is mounted to acrylic backer plate. Large format printed insert sits behind matte acrylic lens. Insert should fit tight against acrylic window for optimal appearance. Sign footer is flush with surface of sign cabinet. Window is removed from frame with a suction cup tool using a lift/pull technique.

**FOOTER:**

Acrylic panel with tactile and Braille characters. Tactile letters painted, Braille painted background color. Panel thickness to equal thickness of APCO sign frame. Panel is mounted to backer plate. Sign footer is flush with surface of sign cabinet.

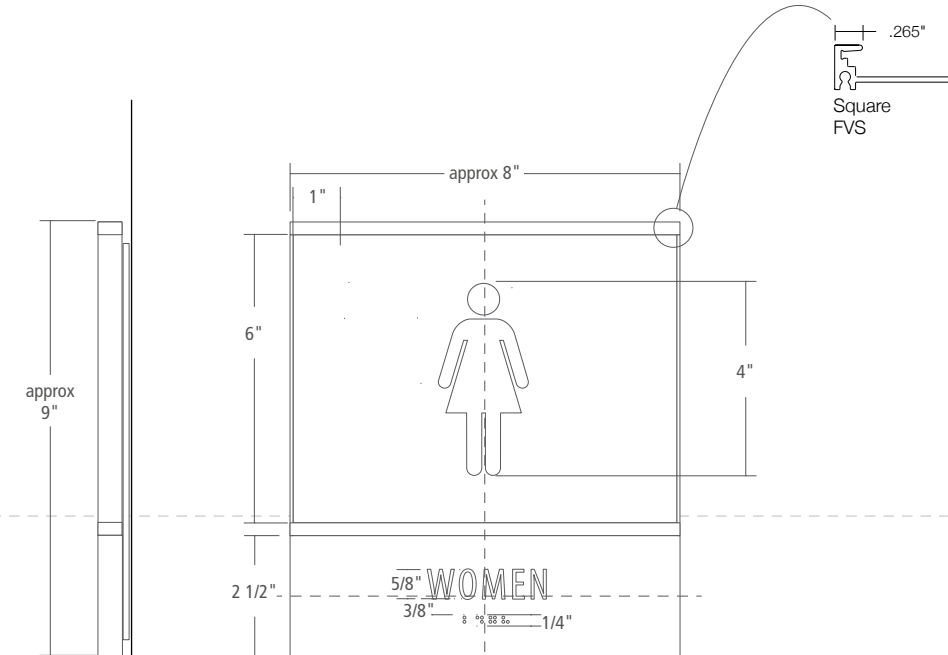

Scale: 3"=1'-0"

**DESTINATION TEXT:**

Myriad Pro Semibold Condensed @ 25% kerning, set for optical display.

**FOOTER TEXT:**

Myriad Pro Condensed @ 75% kerning, set for optical display. Fabricator to confirm dimensions with ADA Standards for Accessible Design.

**R-1 REGULATORY**

Scale: 1"=1'-0" on an 11" x 17" sheet

**R-1 REGULATORY DETAIL**

SPECIFICATION DETAILS

Scale: 3"=1'-0"

**NOTE:**

All public multi-stall restrooms must also include an N-3 sign with gender neutral statement.

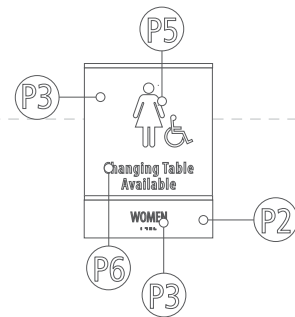
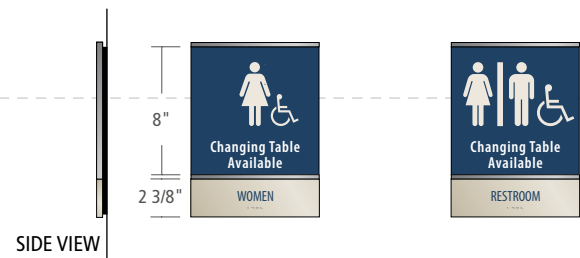
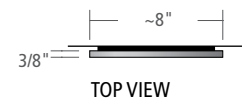

**CABINET:**

APCO FullView Standard Assembly - horizontal configuration, FVS0808(H)MF. Sign frame is mounted to acrylic backer plate. Large format printed insert sits behind matte acrylic lens. Insert should fit tight against acrylic window for optimal appearance. Sign footer is flush with surface of sign cabinet. Window is removed from frame with a suction cup tool using a lift/pull technique.

**FOOTER:**

Acrylic panel with tactile and Braille characters. Tactile letters painted, Braille painted background color. Panel thickness to equal thickness of APCO sign frame. Panel is mounted to backer plate. Sign footer is flush with surface of sign cabinet.

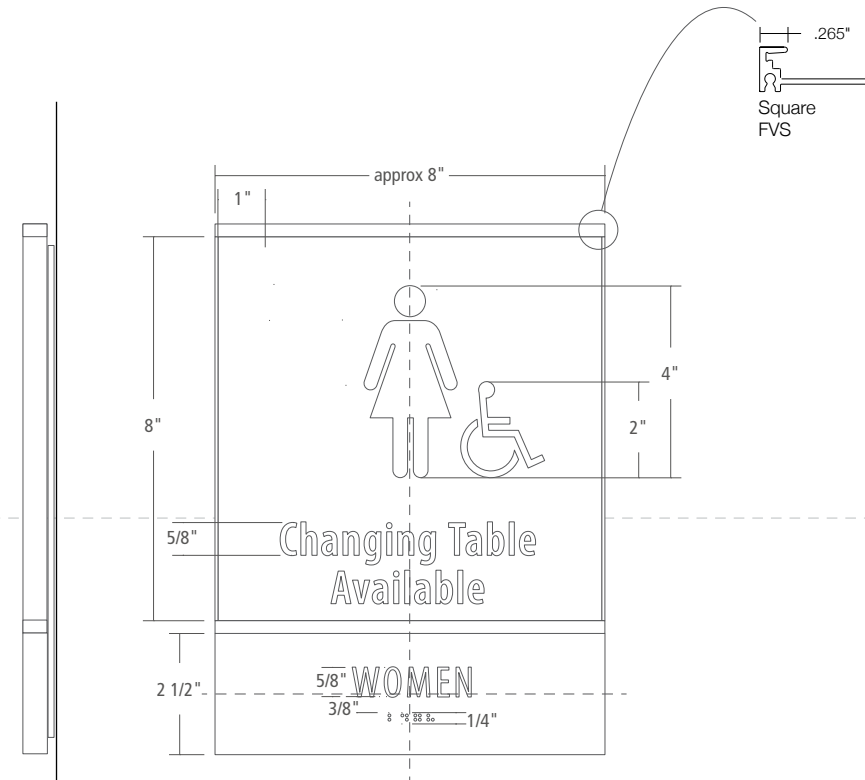

Scale: 3" = 1'-0"

**DESTINATION TEXT:**

Myriad Pro Semibold Condensed @ 25% kerning, set for optical display.

**FOOTER TEXT:**

Myriad Pro Condensed @ 75% kerning, set for optical display. Fabricator to confirm dimensions with ADA Standards for Accessible Design.

**R-1a REGULATORY**  
Scale: 1" = 1'-0" on an 11" x 17" sheet

**R-1a REGULATORY DETAIL**  
SPECIFICATION DETAILS  
Scale: 1" = 1'-0" on an 11" x 17" sheet

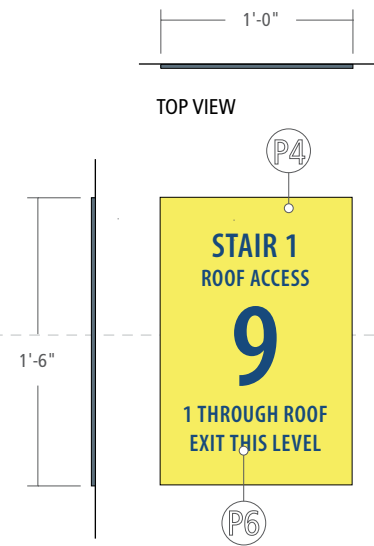

TOP VIEW

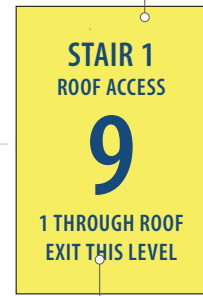

**SIGN PLAQUE:**

1/4" Photoluminescent (Glow in the Dark) acrylic panel. Silk screened or direct to substrate printed Dark Blue photoluminescent letters. Text is set in all uppercase letters. Center entire composition horizontally and vertically on sign panel.  
-Sign to be Photoluminescent per OSSC 1022.8.1.6

**FONT:**

Myriad Pro SemiBold Condensed @ 25% kerning. All capital letters.

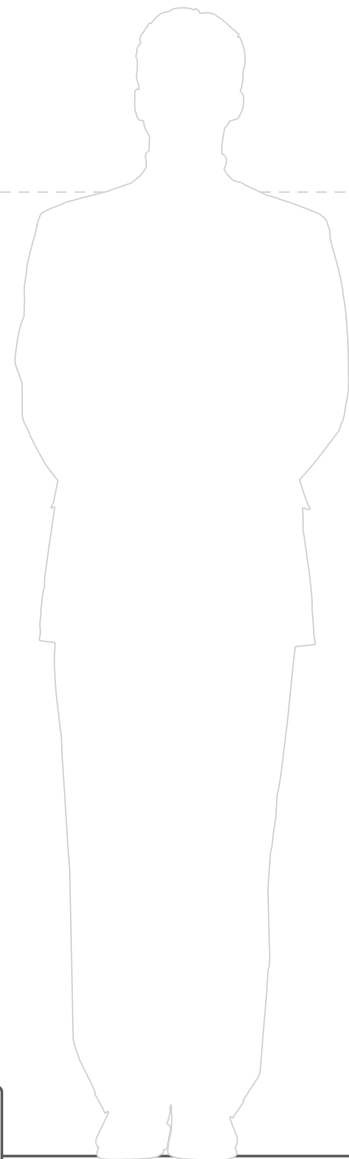

**R-2 REGULATORY STAIRWELL**

Scale: 1"=1'-0" on an 11" x 17" sheet

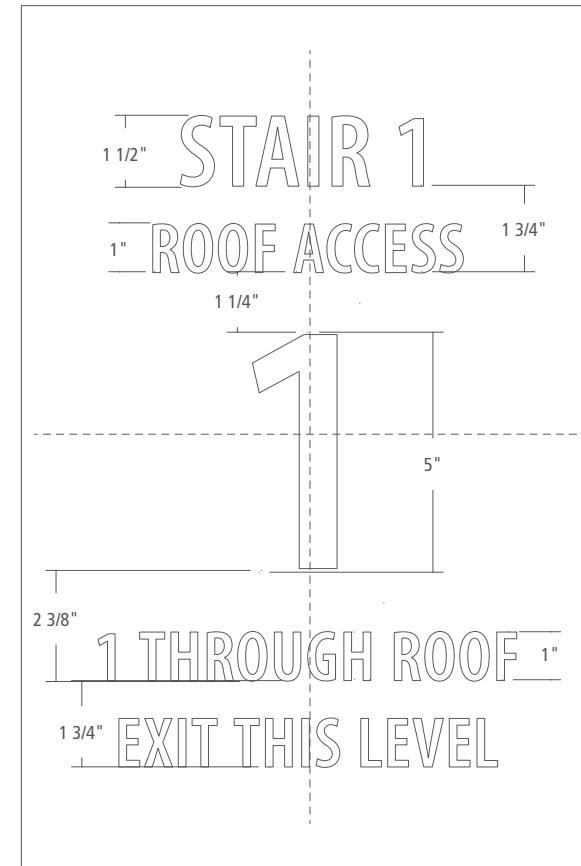

**FONT:**

Myriad Pro SemiBold Condensed @ 25% kerning. All capital letters.

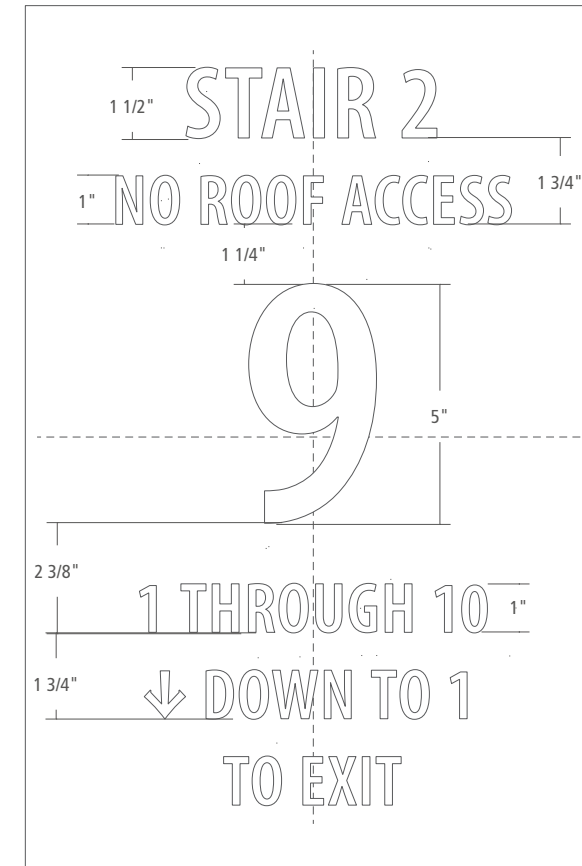

Alternate Layout

**R-2 REGULATORY STAIRWELL DETAIL**

SPECIFICATION DETAILS  
Scale: 3"=1'-0"



**SIGN PLAQUE:**

1/4" Photoluminescent (Glow in the Dark) acrylic panel. Silk screened or direct to substrate printed Dark Blue photoluminescent tactile letters. Text is set in all uppercase letters. Center entire composition horizontally and vertically on sign panel. Grade 2 Braille characters and background are photoluminescent.

**FONT:**

Myriad Pro SemiBold Condensed. All capital letters.

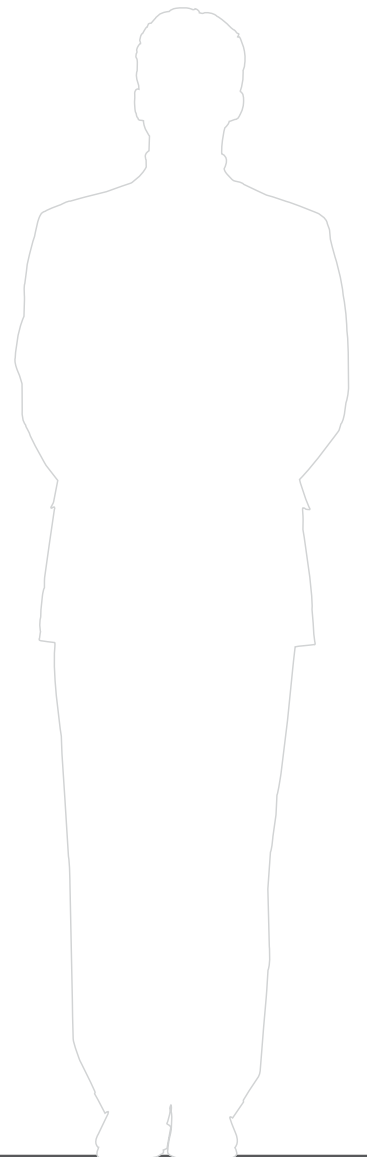

R-3 REGULATORY, EXIT  
SPECIFICATION DETAILS  
Scale: 1"=1'-0"



## DECORATIVE AND CUSTOM

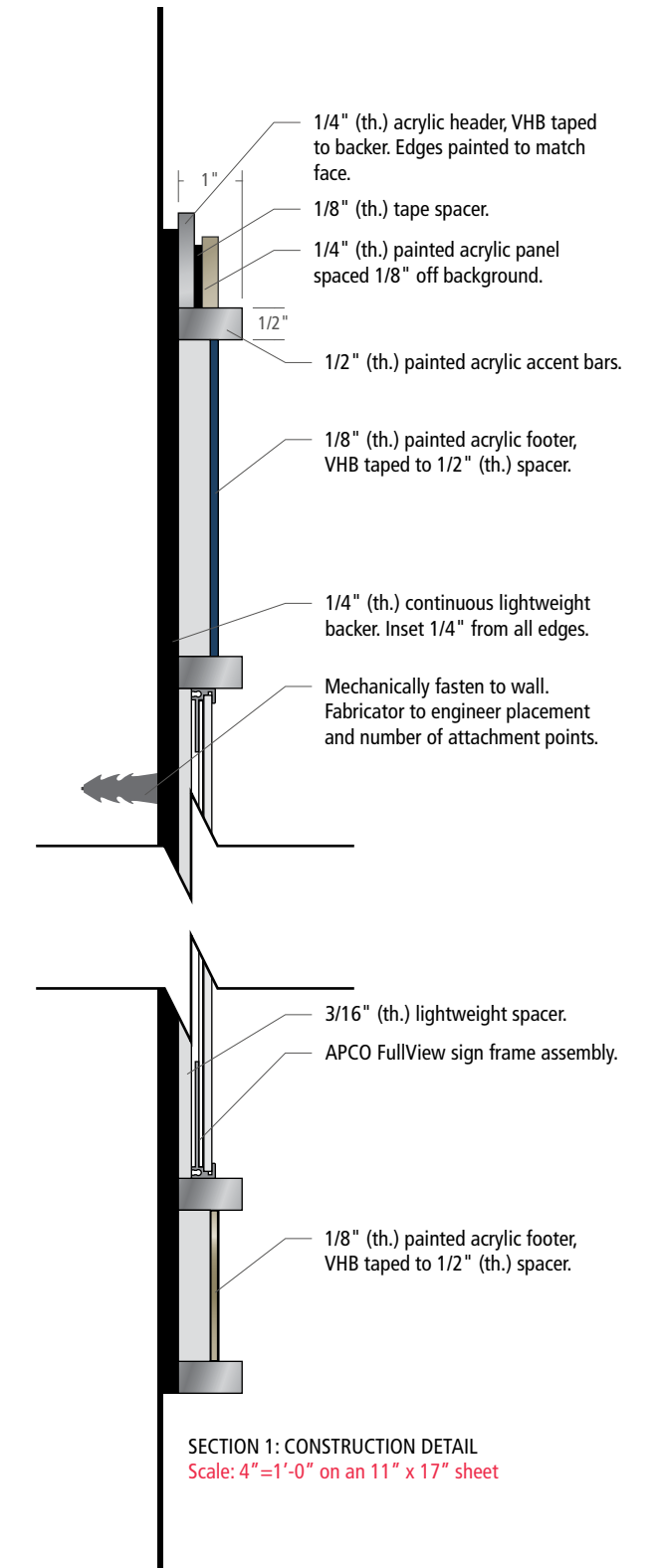
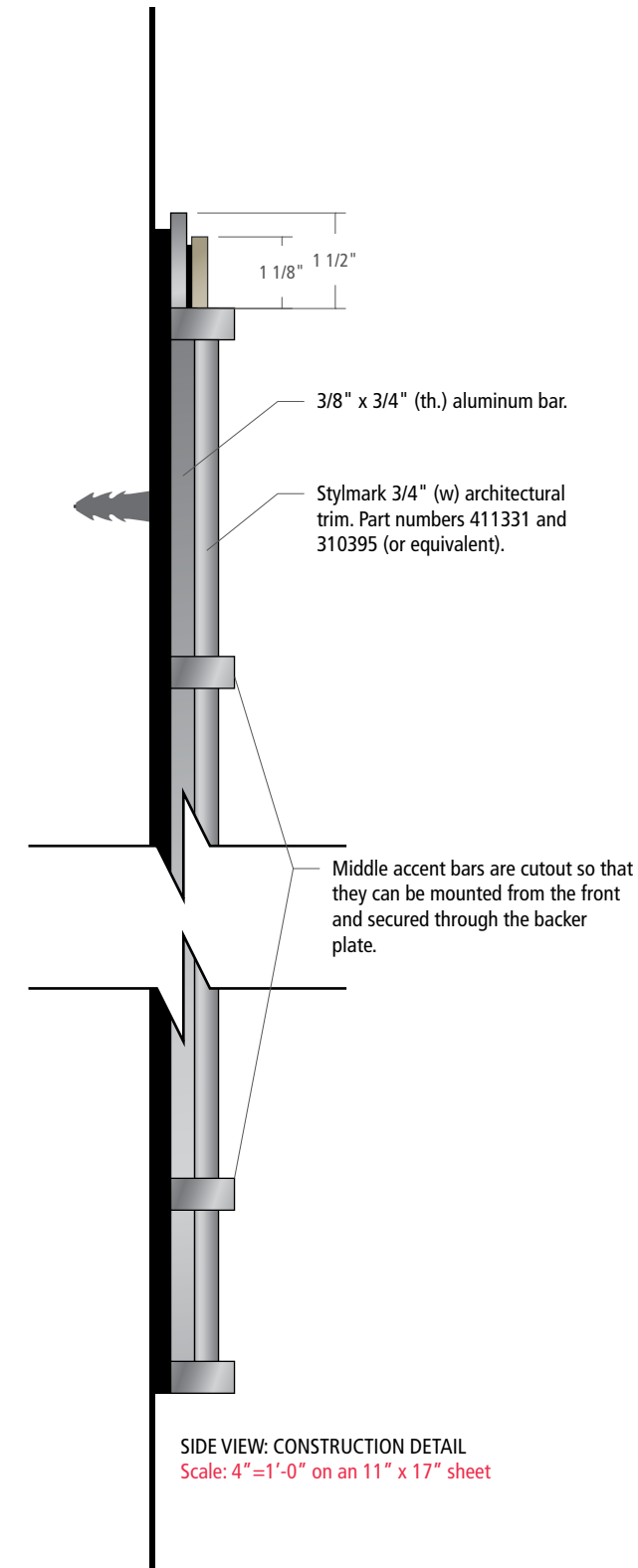
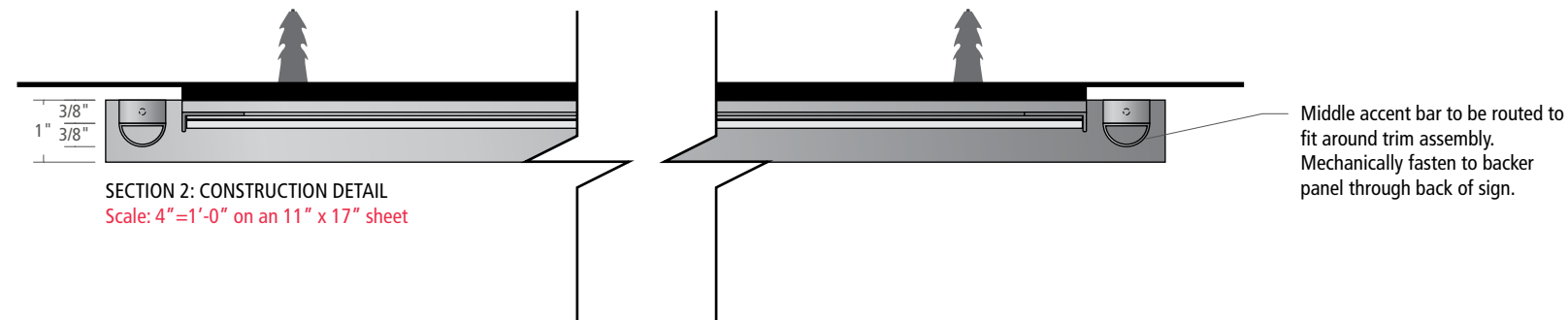
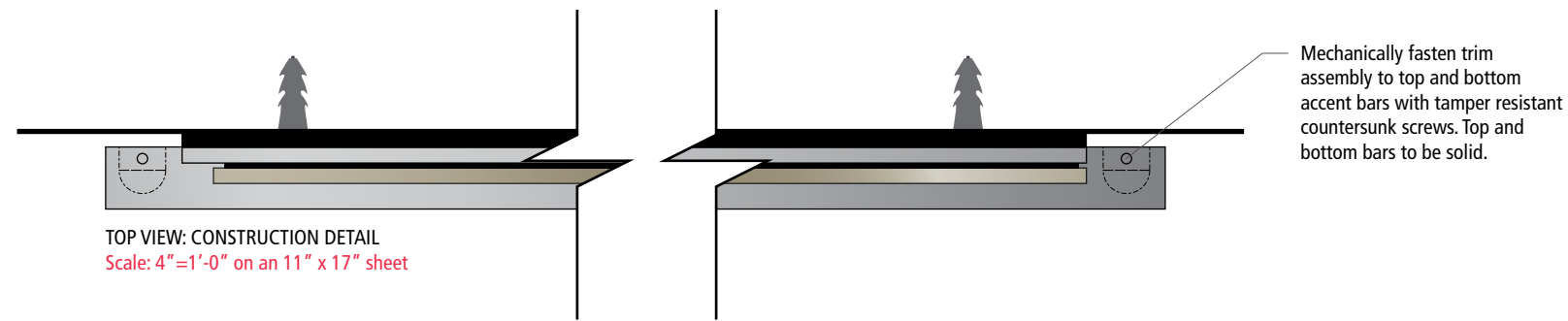

**DIRECTORY SIGN DECORATIVE, CONSTRUCTION DETAILS**  
Scale: 4"=1'-0" on an 11" x 17" sheet

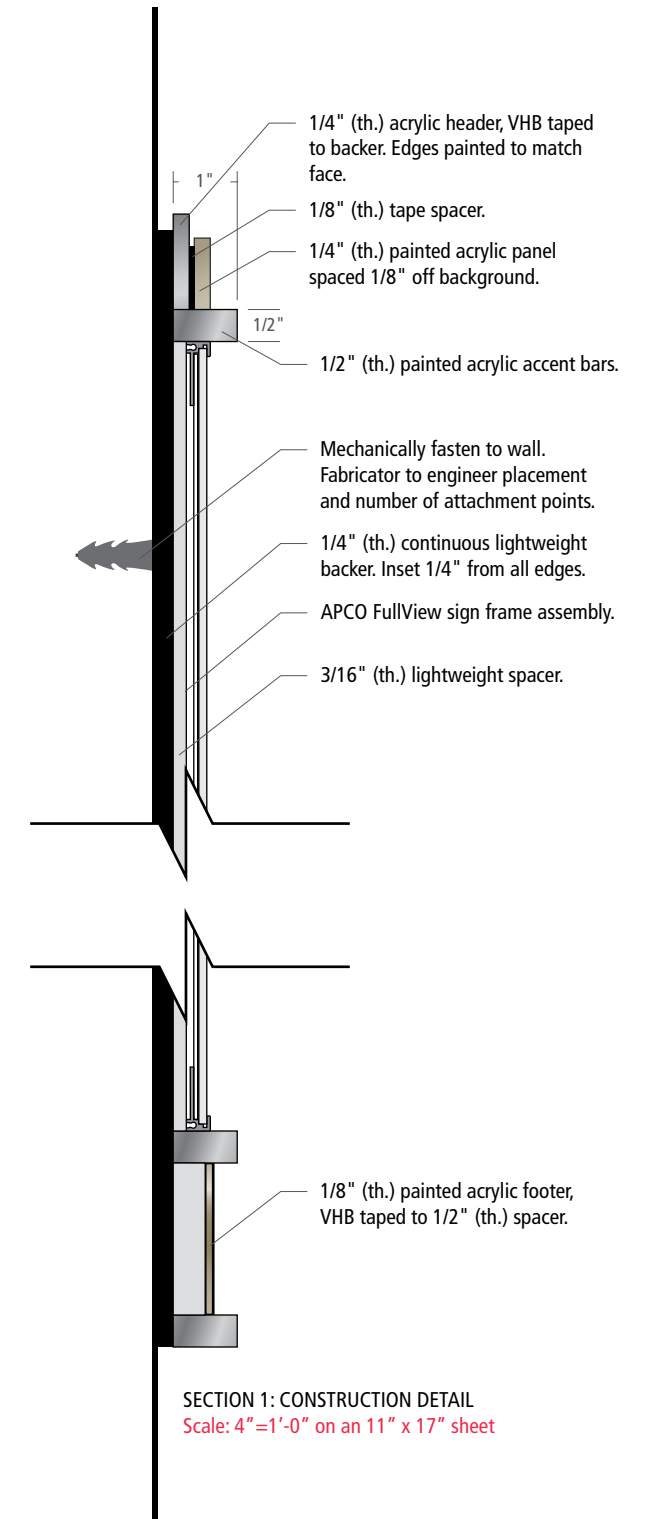
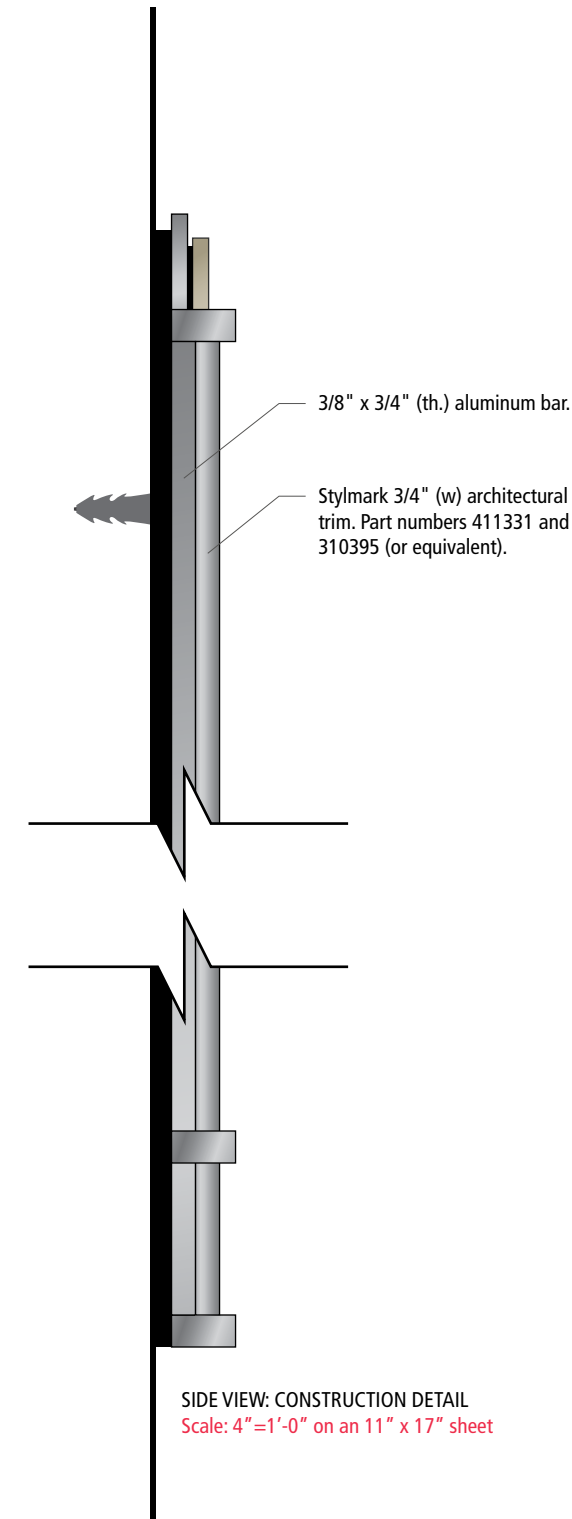
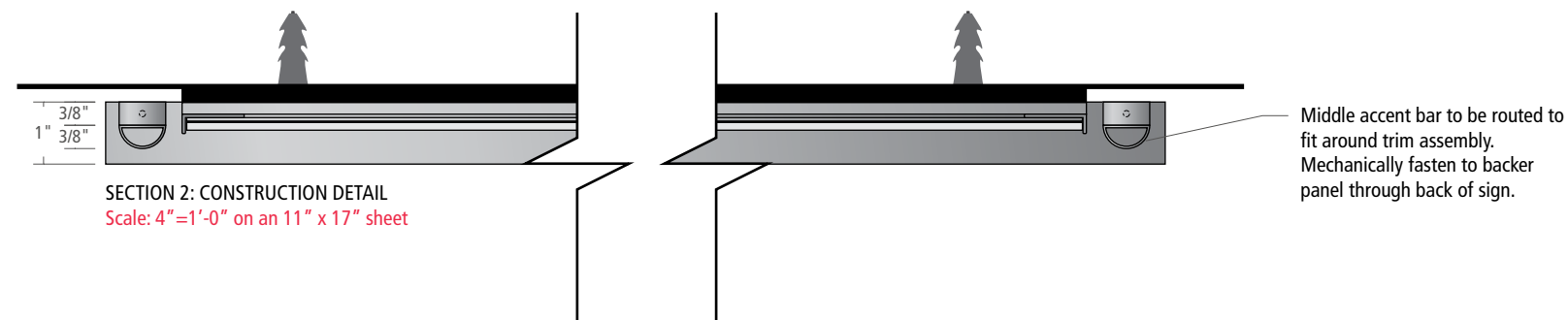
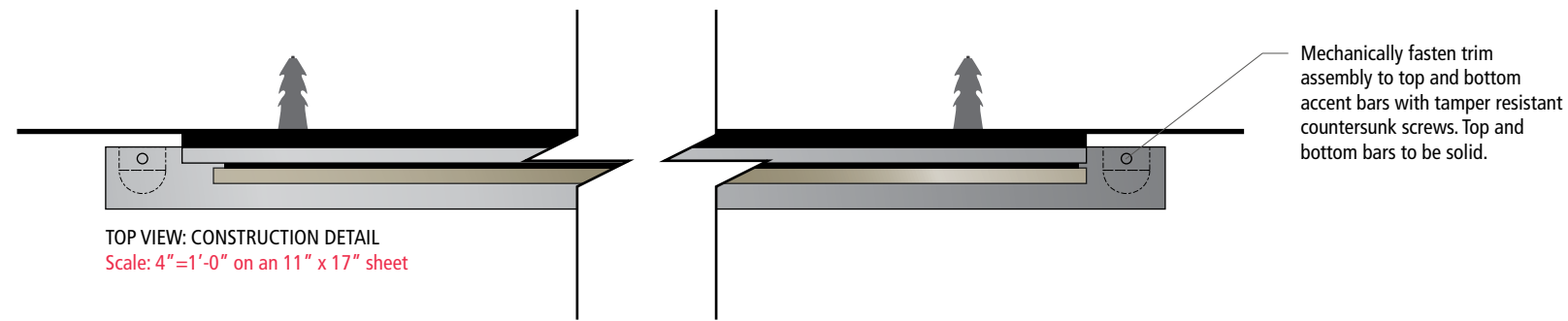

**GUIDE SIGN DECORATIVE, CONSTRUCTION DETAILS**  
 Scale: 4"=1'-0" on an 11" x 17" sheet



**EXISTING CABINET**

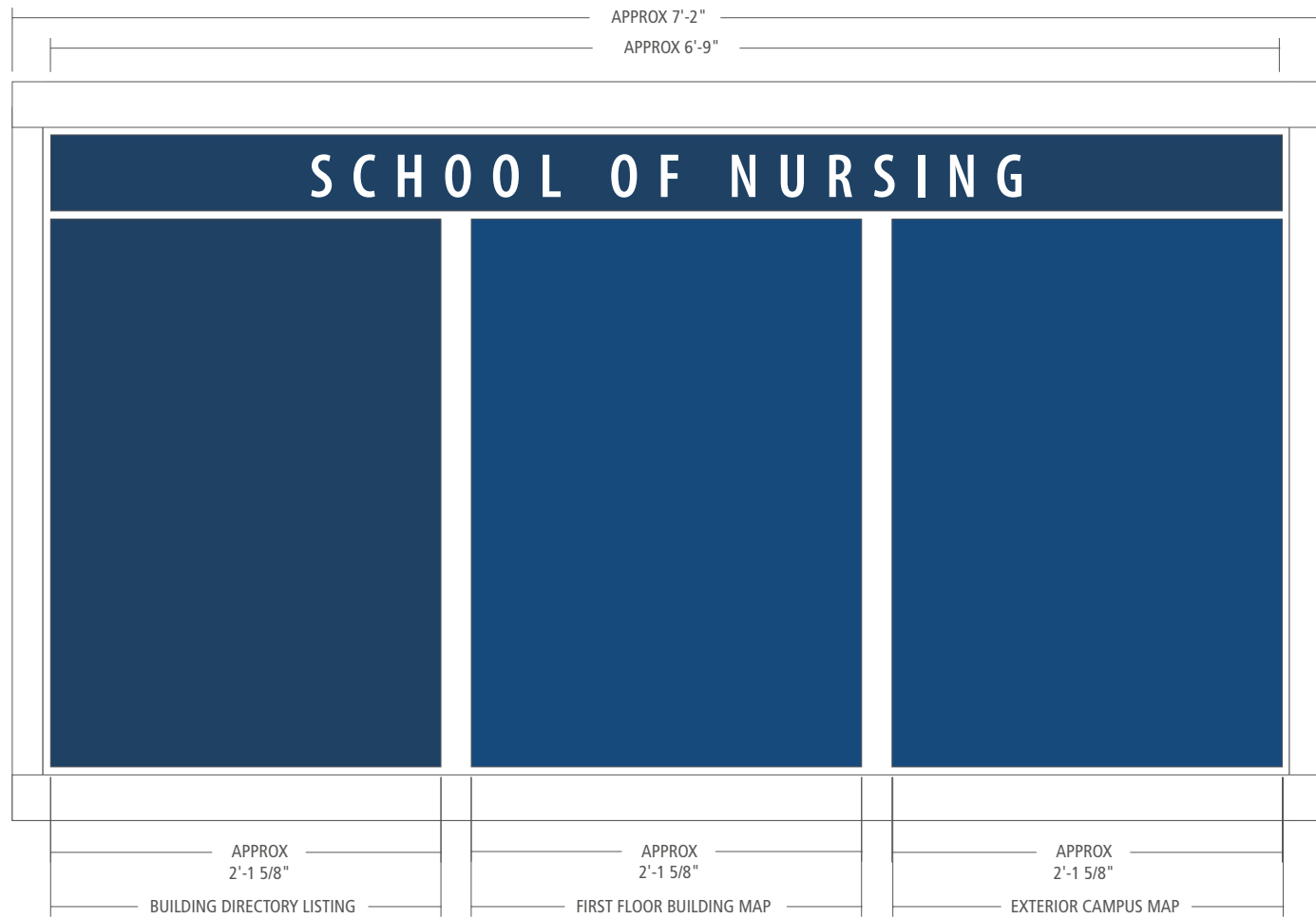

**REPLACEMENT DIRECTORY HEADER**

Painted acrylic header with silk-screened text and graphics. Fabricator to confirm thickness of existing header and replace with same size acrylic header.

**INSERTS**

Large format printed inserts sit behind glass windows. Inserts should fit tight against window for optimal appearance. Fabricator to remove old "slat" system and engineer backing to house inserts. Backing should fit within existing cabinet.

**MEASUREMENTS**

Overall measurements are provided for approximate sizing. It will be the fabricators responsibility to confirm actual dimensions prior to fabrication.



EXISTING CABINET



**D-2e MAIN DIRECTORY, WALL MOUNTED, EXISTING CABINET**

Scale: 1"=1'-0" on an 11" x 17" sheet

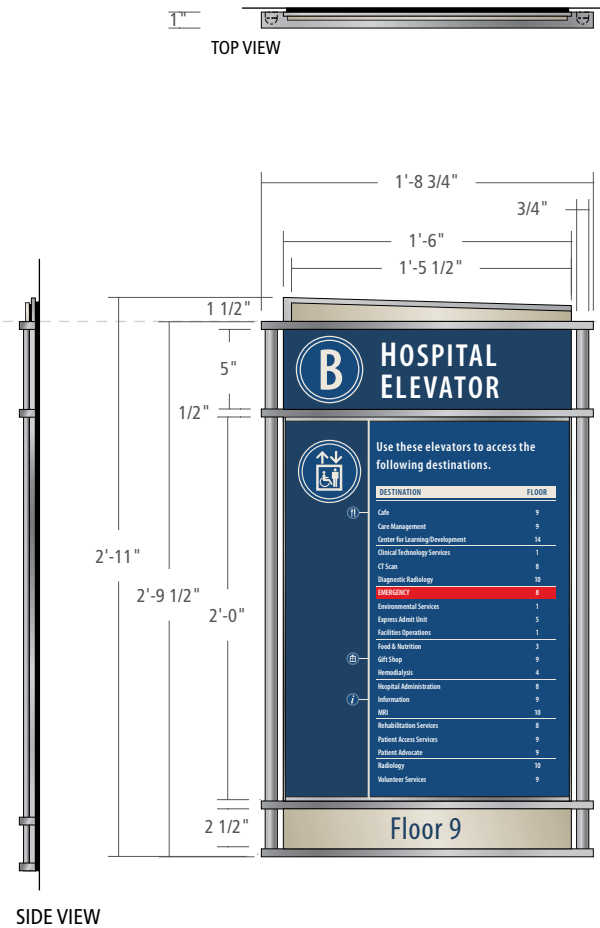

**CUSTOM ELEMENTS:**

**HEADER:** Custom fabricated cabinet with painted acrylic panels. Acrylic panels are mounted directly to backer plate.

**SIDE RAILS:** Constructed from extruded aluminum parts and painted.

**CABINET:**

APCO FullView FVS2418(H)MF - horizontal configuration, pin to be installed in the upper left position (with no pin), mounted to acrylic panel. Large format printed insert sits behind matte acrylic lens. Insert should fit tight against acrylic window for optimal appearance. Window is removed from frame with a suction cup tool using a lift/pull technique. Cabinet to be surface flush with decorative header above.

**BACKER PLATE:**

1/4" (th.) acrylic panel, inset 1/4" from edges (only behind middle part of sign).

**FOOTER:** Acrylic panel with silk-screened graphics. Panel surface to be flush with decorative header and cabinet above.

See detail drawing for sections and specifications.

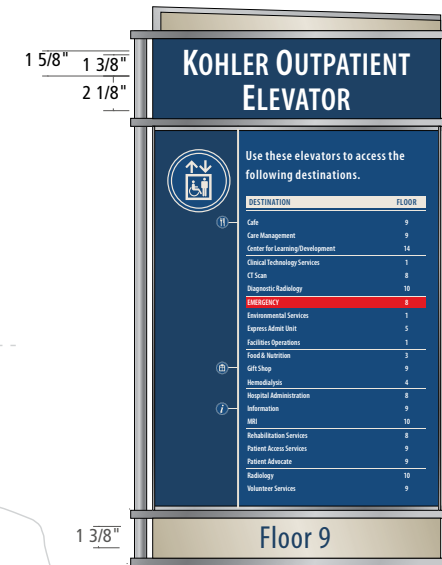
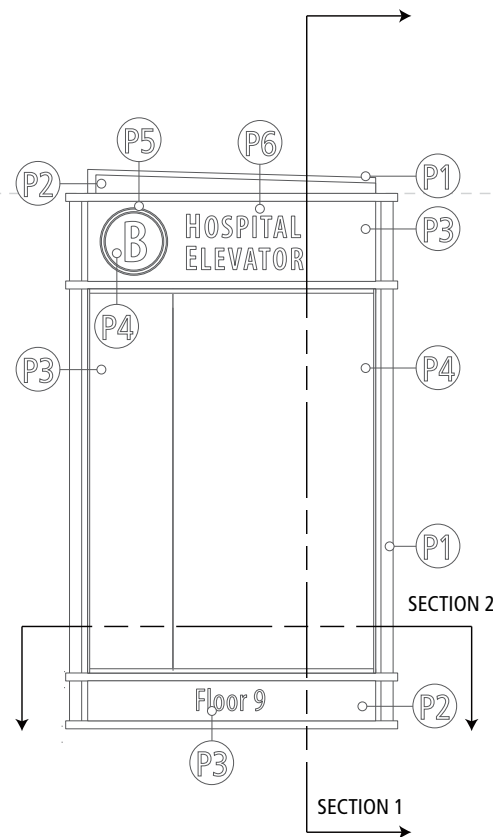

**HEADER FONT:**  
Myriad Pro Semibold  
Condensed @ 25%  
kerning. Set for Optical  
kerning. Text is in all  
capital letters.

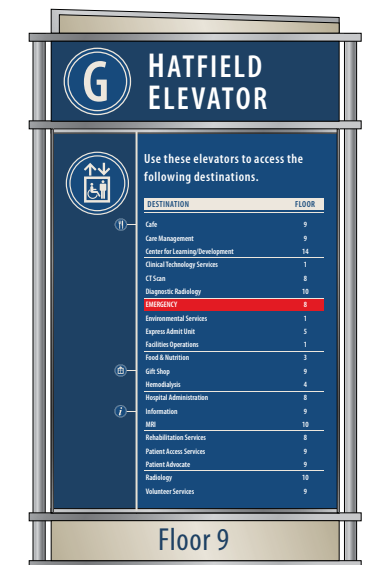
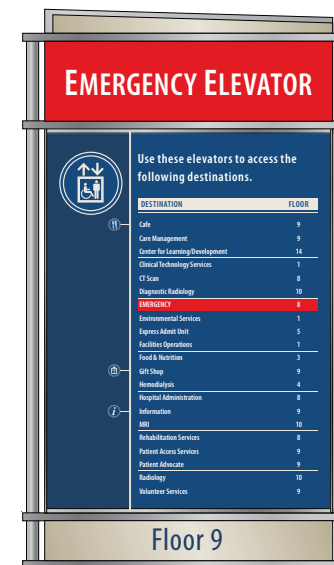

**FOOTER FONT:**  
Myriad Pro Condensed  
@ 25% kerning. Set for  
Optical kerning.

**D-3 ELEVATOR DIRECTORY DECORATIVE**  
Scale: 1"=1'-0" on an 11" x 17" sheet

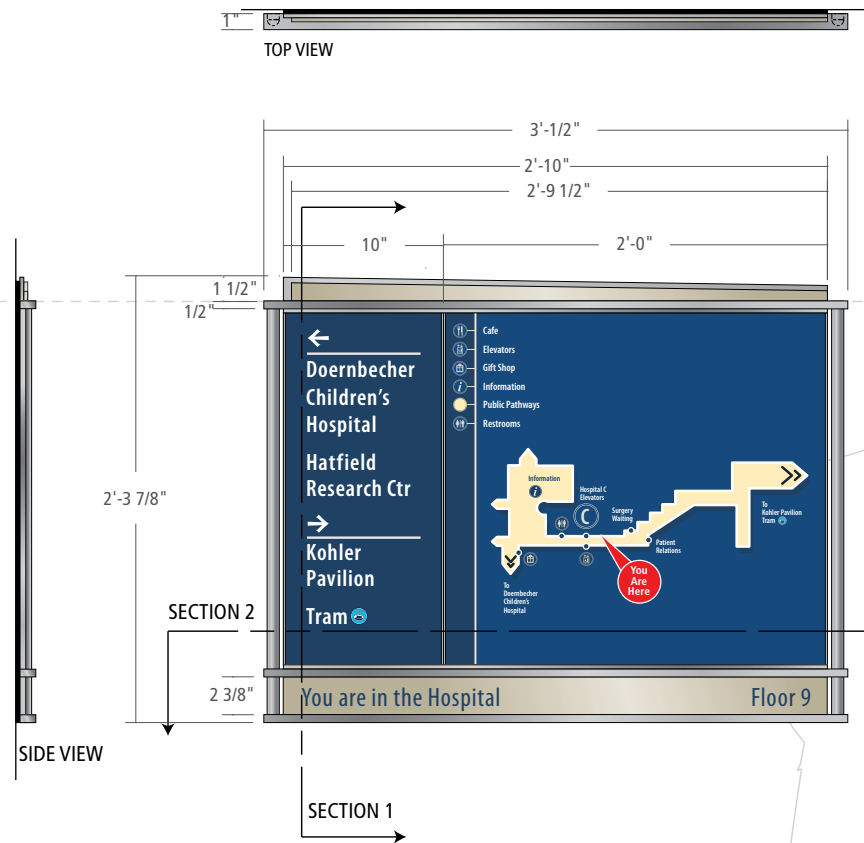

**CUSTOM ELEMENTS:**

**HEADER:**  
Fabricated from painted, layered acrylic panels attached to backer panel with VHB tape.

**SIDE RAILS:**  
Constructed from extruded aluminum parts and painted.

**FOOTER:**  
Acrylic panel with silk-screened graphics. Panel surface to be flush with decorative header and cabinet above.

See guide detail page for sections and specifications.

**SIGN FRAME:**  
APCO FullView FVS2234(H)MF - horizontal configuration, pin to be installed in the upper left position (with no pin), mounted to acrylic panel. Large format printed insert sits behind matte acrylic lens. Insert should fit tight against acrylic window for optimal appearance. Window is removed from frame with a suction cup tool using a lift/pull technique. Cabinet to be surface flush with decorative header above.

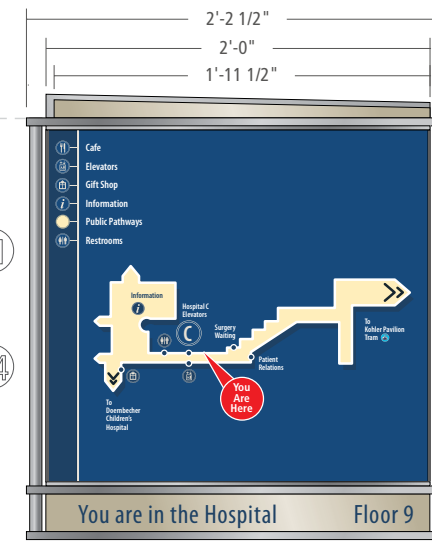
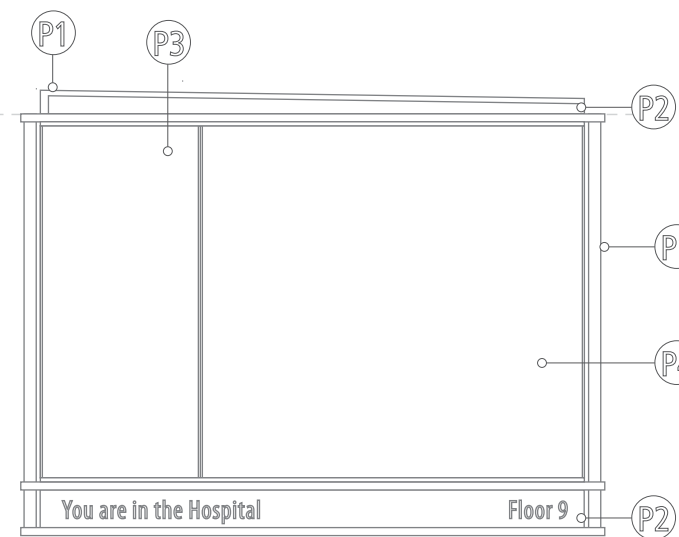

Similar construction to D-4

**SIGN FRAME:**  
APCO FullView FVS2224(H)MF - horizontal configuration, pin to be installed in the upper left position (with no pin), mounted to acrylic panel. Large format printed insert sits behind matte acrylic lens. Insert should fit tight against acrylic window for optimal appearance. Window is removed from frame with a suction cup tool using a lift/pull technique. Cabinet to be surface flush with decorative header above.

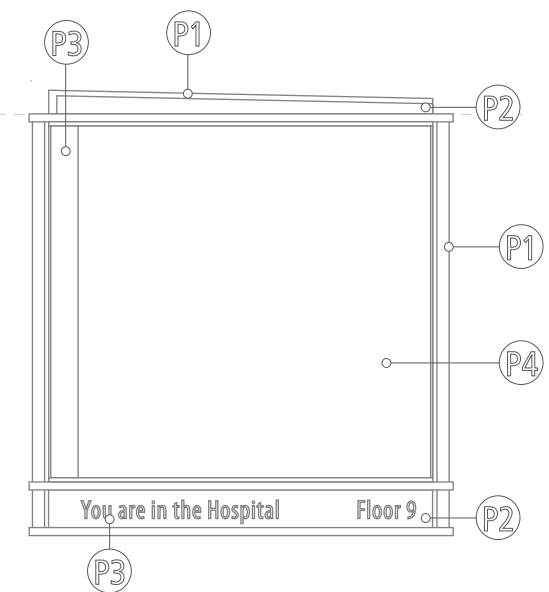

**D-4 STRIP MAP w/ GUIDE INFO, DECORATIVE**  
Scale: 1"=1'-0" on an 11" x 17" sheet

**D-4a STRIP MAP, DECORATIVE**  
Scale: 1"=1'-0" on an 11" x 17" sheet

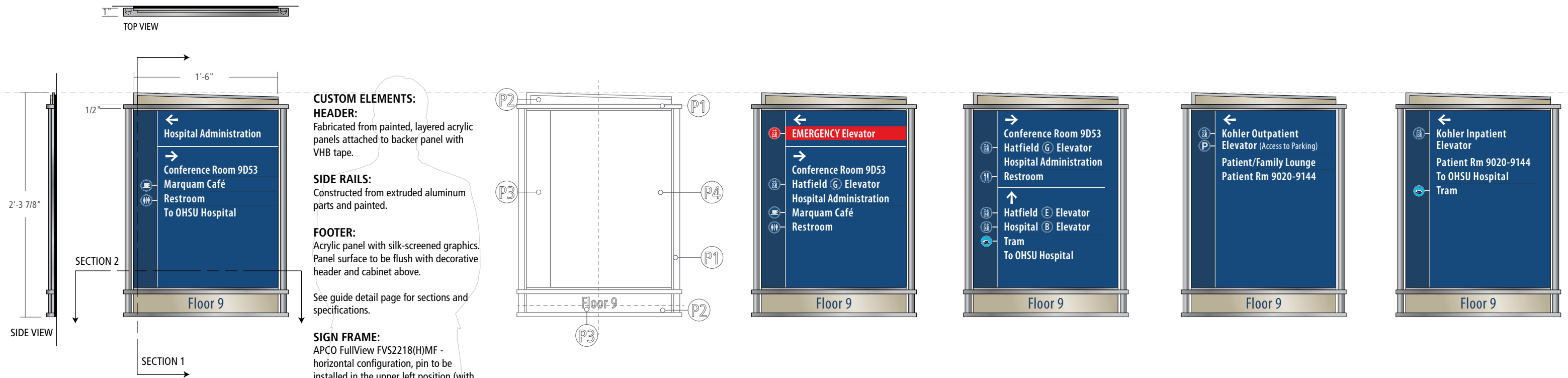

**CUSTOM ELEMENTS:**

**HEADER:**  
Fabricated from painted, layered acrylic panels attached to backer panel with VHB tape.

**SIDE RAILS:**  
Constructed from extruded aluminum parts and painted.

**FOOTER:**  
Acrylic panel with silk-screened graphics. Panel surface to be flush with decorative header and cabinet above.

See guide detail page for sections and specifications.

**SIGN FRAME:**  
APCO FullView FVS2218(H)MF - horizontal configuration, pin to be installed in the upper left position (with no pin), mounted to acrylic panel. Large format printed insert sits behind matte acrylic lens. Insert should fit tight against acrylic window for optimal appearance. Window is removed from frame with a suction cup tool using a lift/pull technique. Cabinet to be surface flush with decorative header above.

**G-1 GUIDE SIGN, LARGE, DECORATIVE**  
Scale: 1" = 1'-0" on an 11" x 17" sheet

**APCO FULLVIEW**

APCO FullView FVS2218(H)MF - horizontal configuration (no pin)

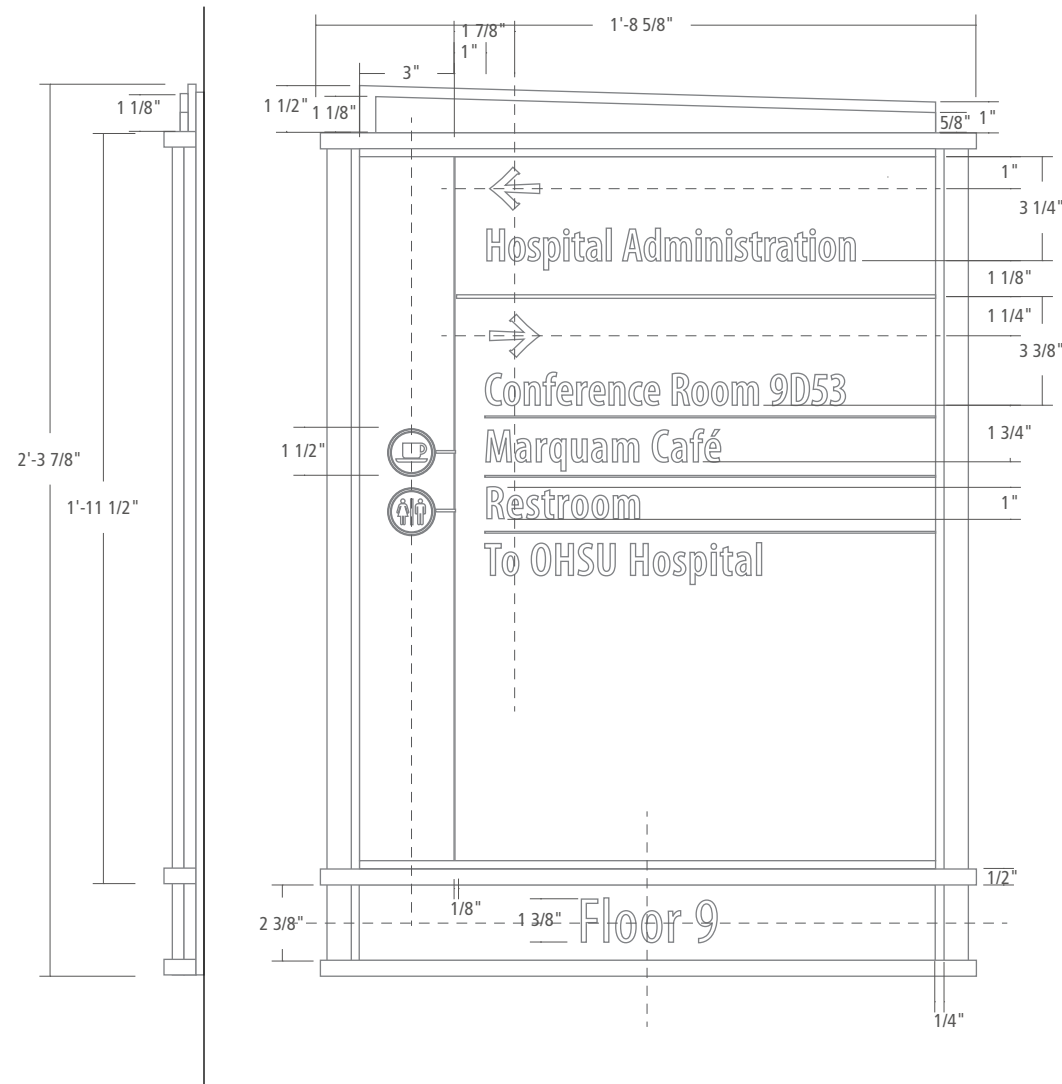

**TYPICAL DESTINATION TEXT:**

Myriad Pro Semibold Condensed, 1" cap @ 25% kerning, set for optical display. Some destinations will require 5% or 10% kerning.

**CONFERENCE ROOM 9D53 TEXT:**

Myriad Pro Semibold Condensed @ 10% kerning, set for optical display.

**HOSPITAL ADMINISTRATION TEXT:**

Myriad Pro Semibold Condensed @ 5% kerning, set for optical display.

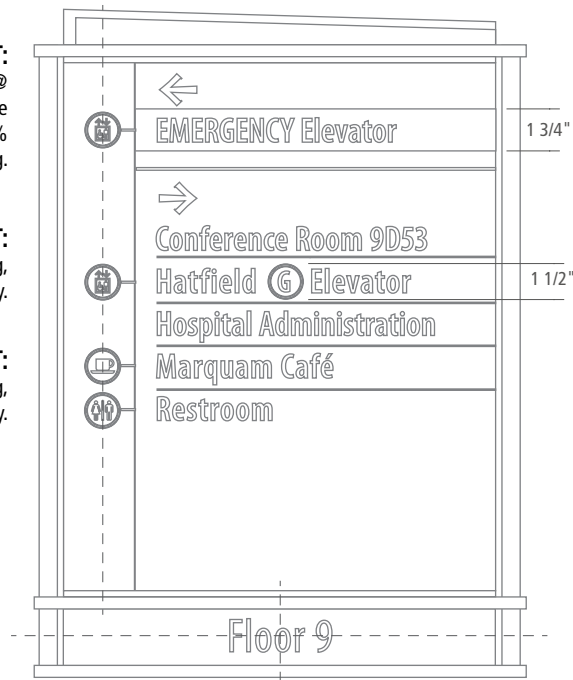

Scale: 1 1/2" = 1'-0"

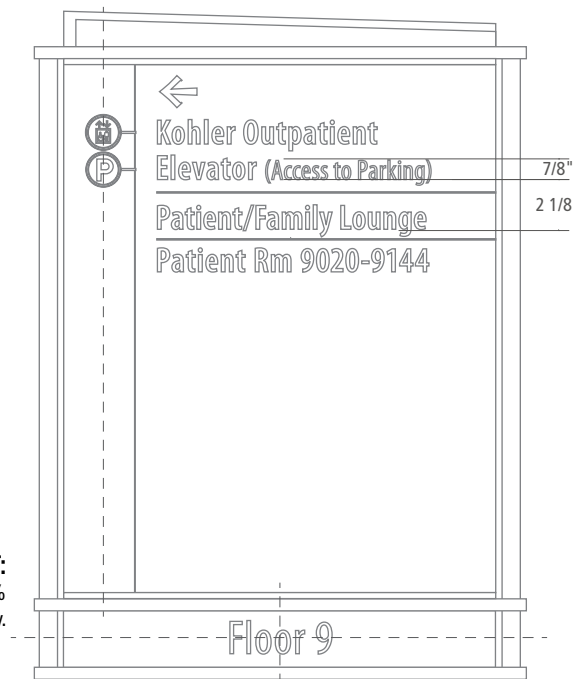
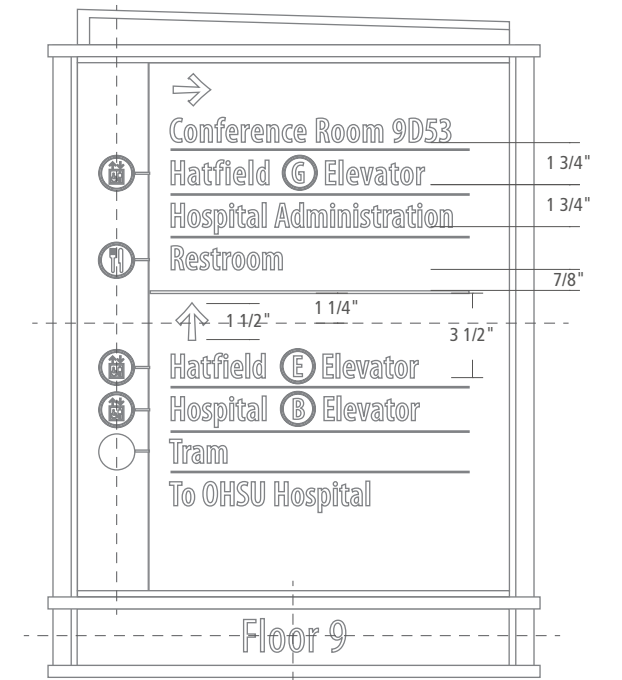

**FOOTER TEXT:**

Myriad Pro Condensed @ 25% kerning, set for optical display.

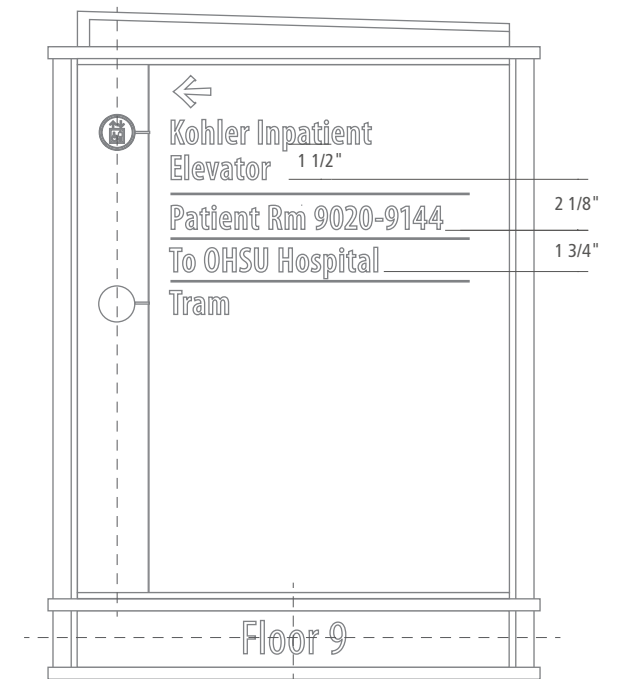

**G-1 GUIDE SIGN, LARGE, DECORATIVE, DETAIL**  
 SPECIFICATION DETAILS  
 Scale: 2" = 1'-0"



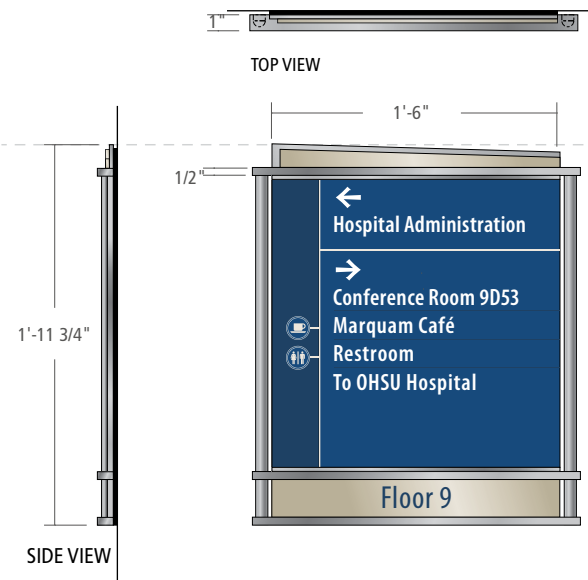

**CUSTOM ELEMENTS:**

**HEADER:**  
Fabricated from painted, layered acrylic panels attached to backer panel with VHB tape.

**SIDE RAILS:**  
Constructed from extruded aluminum parts and painted.

**FOOTER:**  
Acrylic panel with silk-screened graphics. Panel surface to be flush with decorative header and cabinet above.

See guide detail page for sections and specifications.

**SIGN FRAME:**

APCO FullView FVS1818(H)MF - horizontal configuration, pin to be installed in the upper left position (with no pin), mounted to acrylic panel. Large format printed insert sits behind matte acrylic lens. Insert should fit tight against acrylic window for optimal appearance. Window is removed from frame with a suction cup tool using a lift/pull technique. Cabinet to be surface flush with decorative header above.

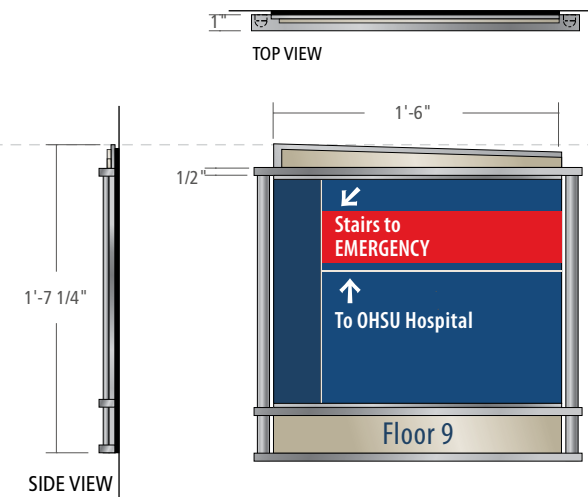
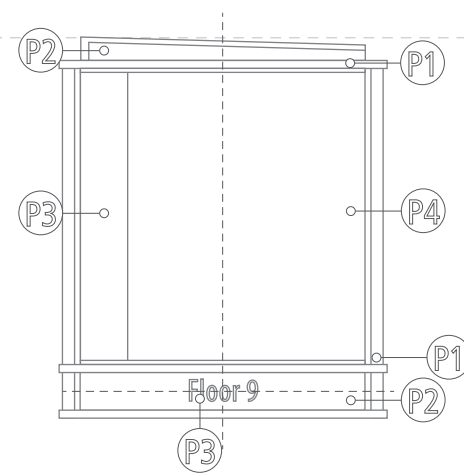

**SIGN FRAME:**

APCO FullView FVS1418(H)MF - horizontal configuration, pin to be installed in the upper left position (with no pin), mounted to acrylic panel. Large format printed insert sits behind matte acrylic lens. Insert should fit tight against acrylic window for optimal appearance. Window is removed from frame with a suction cup tool using a lift/pull technique. Cabinet to be surface flush with decorative header above.

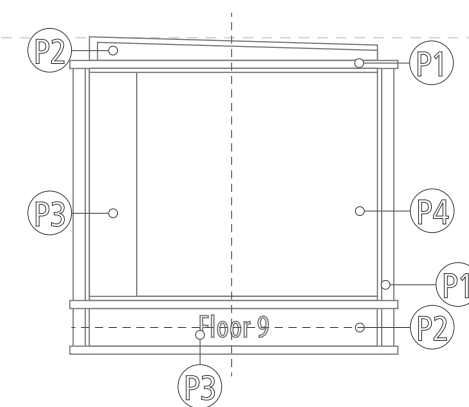

**G-1a GUIDE SIGN, MEDIUM, DECORATIVE**

Scale: 1"=1'-0" on an 11" x 17" sheet

**G-1b GUIDE SIGN, SMALL, DECORATIVE**

Scale: 1"=1'-0" on an 11" x 17" sheet

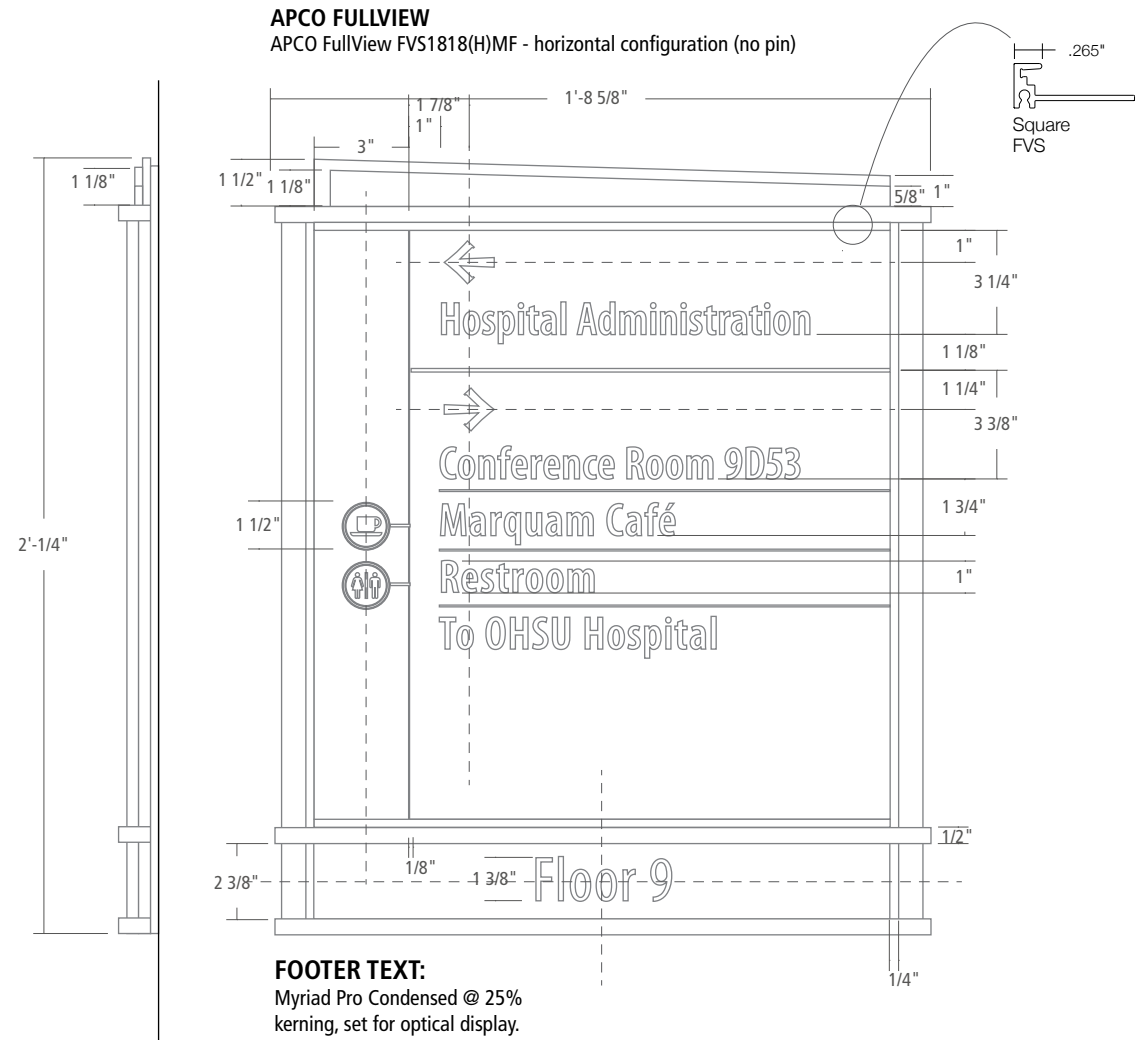

**TYPICAL DESTINATION TEXT:**  
Myriad Pro Semibold Condensed, 1" cap @  
25% kerning, set for optical display. Some  
destinations will require 5% or 10%  
kerning.

**APCO FULLVIEW**  
APCO FullView FVS1418(H)MF - horizontal configuration (no pin)

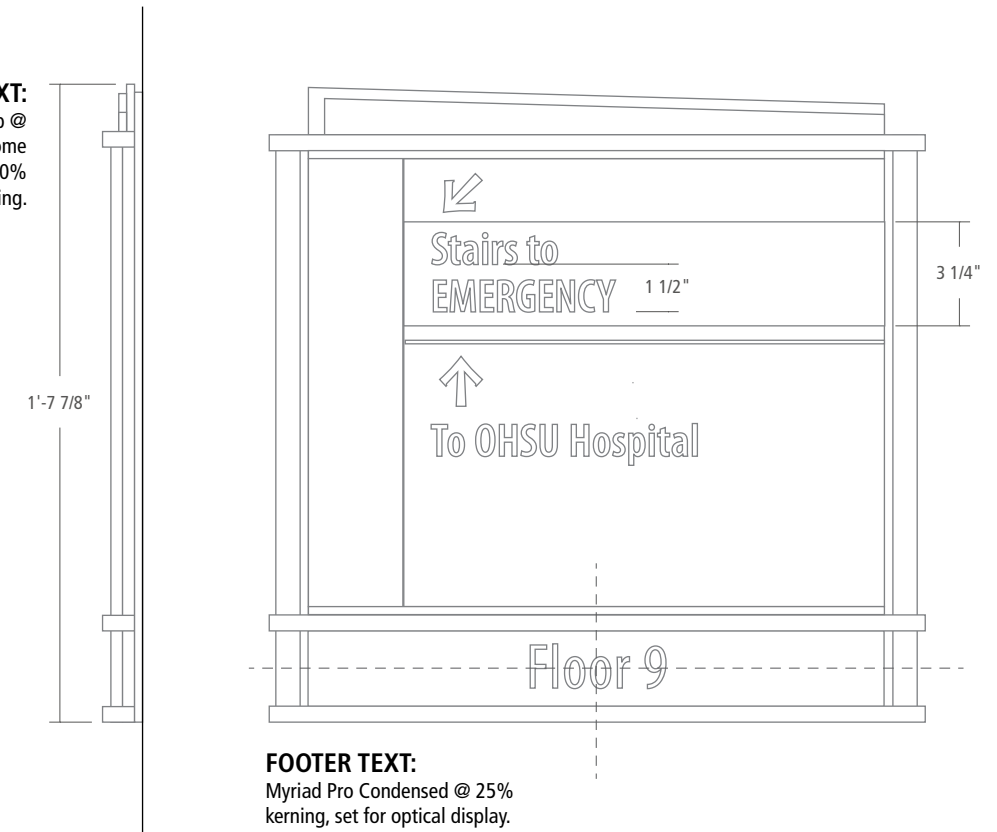

**G-1a GUIDE SIGN, MEDIUM, DECORATIVE DETAIL**  
SPECIFICATION DETAILS  
Scale: 2" = 1'-0"

**G-1b GUIDE SIGN, SMALL, DECORATIVE DETAIL**  
SPECIFICATION DETAILS  
Scale: 2" = 1'-0"



**CONSTRUCTION:**

Sign is to replace existing sign inset into the wall. New sign to match dimensions for height, width and depth. Fabricator to verify dimensions and construction prior to fabrication.

**CABINET:**

Custom APCO FullView-like vertical rail system. Large format printed insert sits behind matte acrylic lens. Insert should fit tight against acrylic window for optimal appearance.

**DIVIDER BAR:**

1/4" (th.) aluminum bar

**FOOTER:**

Acrylic panel with silk-screened graphics. Panel thickness to equal thickness of APCO sign frame. Panel is mounted to backer panel.

**G-4a GUIDE SIGN, CUSTOM**  
Scale: 1"=1'-0" on an 11" x 17" sheet

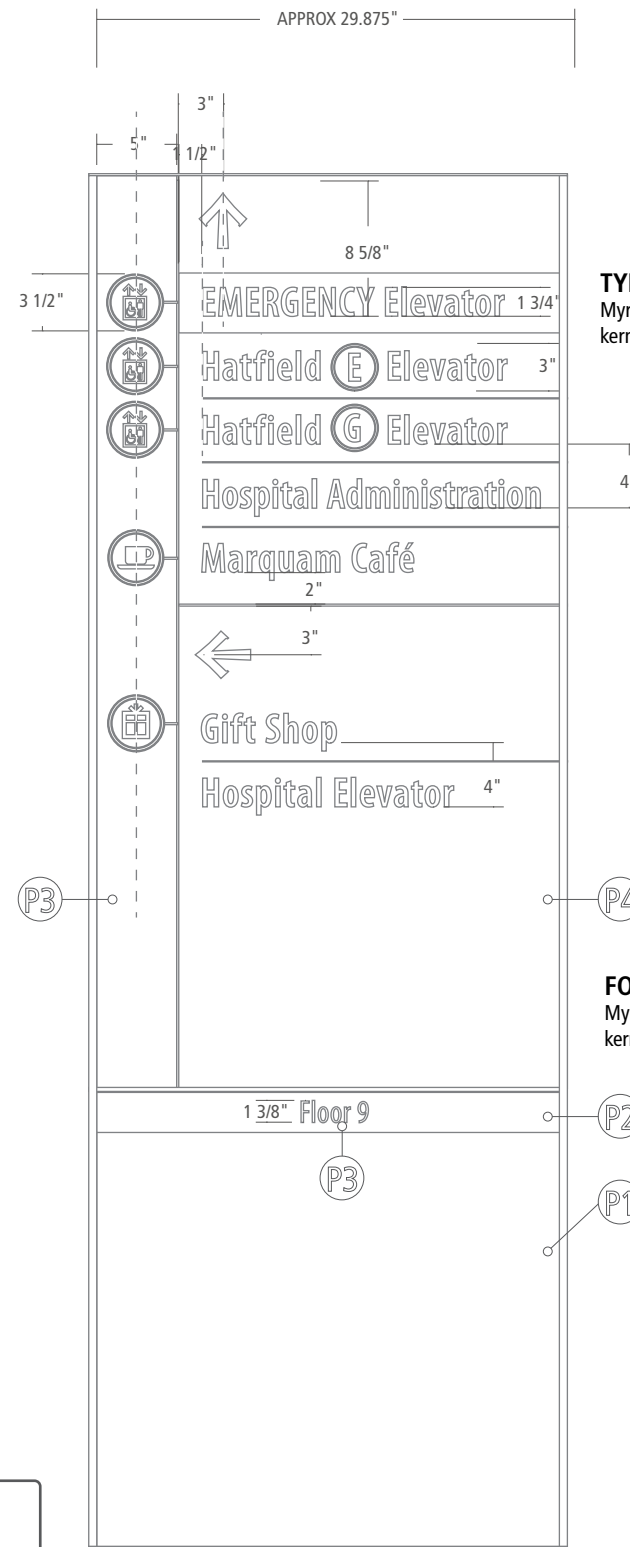

**TYPICAL DESTINATION TEXT:**  
Myriad Pro Semibold Condensed @ 25% kerning, set for optical display.

**FOOTER TEXT:**  
Myriad Pro Condensed @ 20% kerning, set for optical display.

**G-4b GUIDE SIGN, CUSTOM**  
Scale: 1"=1'-0" on an 11" x 17" sheet

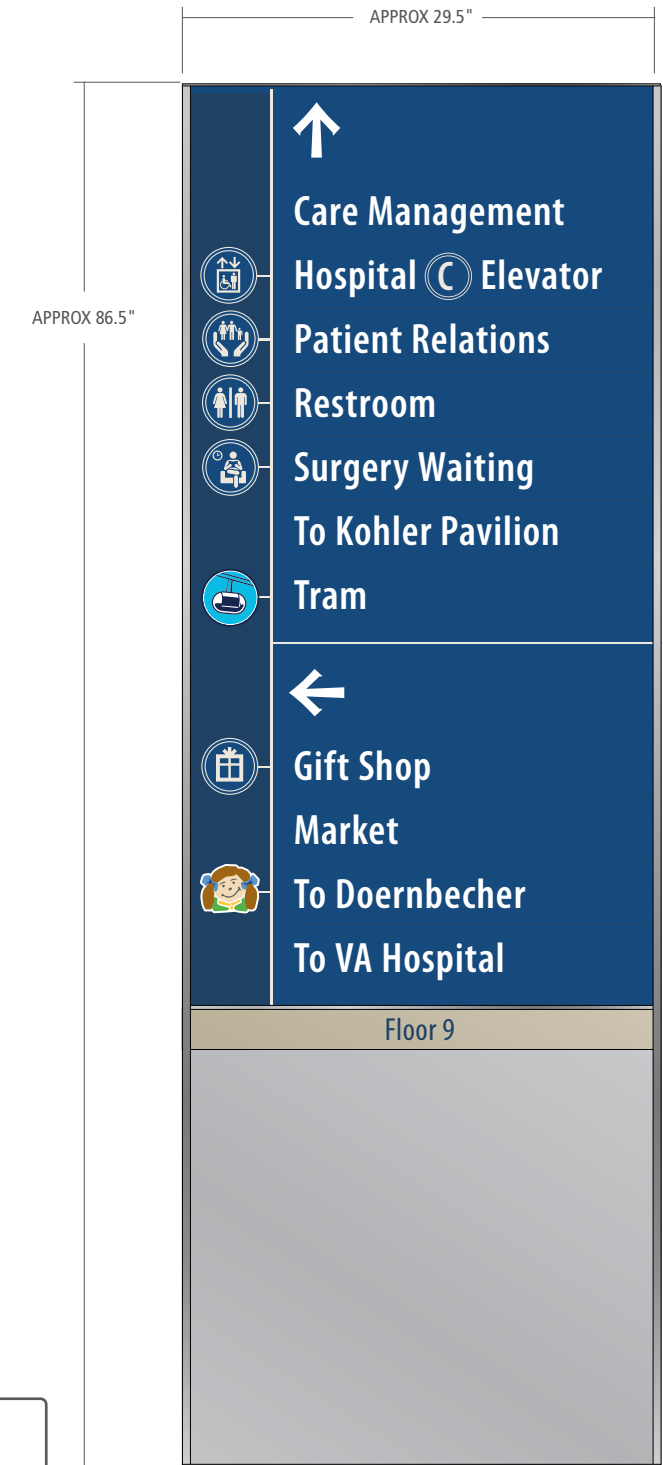

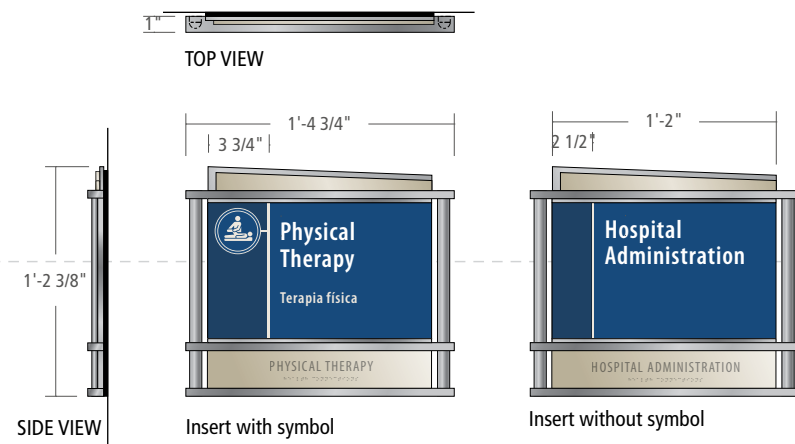

**HEADER:**  
Fabricated from painted, layered acrylic panels attached to backer panel with VHB tape.

**SIDE RAILS:**  
Constructed from extruded aluminum parts and painted.

**FOOTER:**  
Acrylic panel with tactile and Braille characters. Tactile letters and Braille painted background color. Panel surface to be flush with decorative header and cabinet above.

See primary identifier detail page for sections and specifications.

**SIGN FRAME:**  
APCO FullView FVS8514(H)MF - horizontal configuration, pin to be installed in the upper left position (with no pin), mounted to acrylic panel. Large format printed insert sits behind matte acrylic lens. Insert should fit tight against acrylic window for optimal appearance. Window is removed from frame with a suction cup tool using a lift/pull technique. Cabinet to be surface flush with decorative header above.

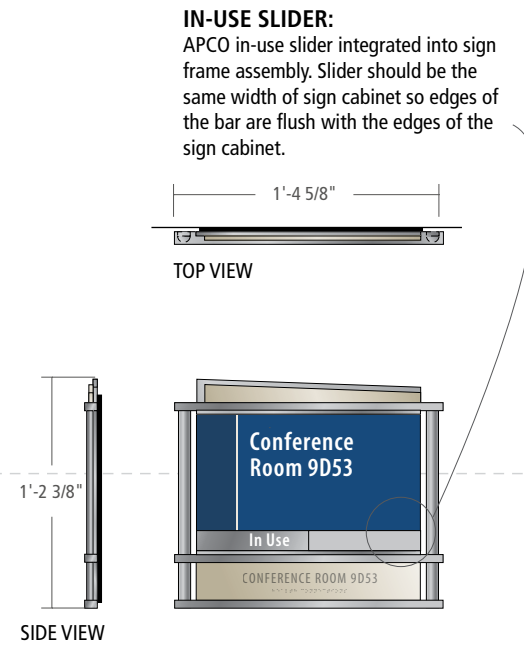

**IN-USE SLIDER:**  
APCO in-use slider integrated into sign frame assembly. Slider should be the same width of sign cabinet so edges of the bar are flush with the edges of the sign cabinet.

**HEADER:**  
Fabricated from painted, layered acrylic panels attached to backer panel with VHB tape.

**SIDE RAILS:**  
Constructed from extruded aluminum parts and painted.

**FOOTER:**  
Acrylic panel with tactile and Braille characters. Tactile letters and Braille painted background color. Panel surface to be flush with decorative header and cabinet above.

See primary identifier detail page for sections and specifications.

**SIGN FRAME:**  
APCO FullView FVS8514(H)MF - horizontal configuration, pin to be installed in the upper left position (with no pin), mounted to acrylic panel. Large format printed insert sits behind matte acrylic lens. Insert should fit tight against acrylic window for optimal appearance. Window is removed from frame with a suction cup tool using a lift/pull technique. Cabinet to be surface flush with decorative header above.

**I-1 PRIMARY ID, DECORATIVE**  
Scale: 1"=1'-0" on an 11" x 17" sheet

**I-1a PRIMARY ID, w/SLIDER, DECORATIVE**  
Scale: 1"=1'-0" on an 11" x 17" sheet

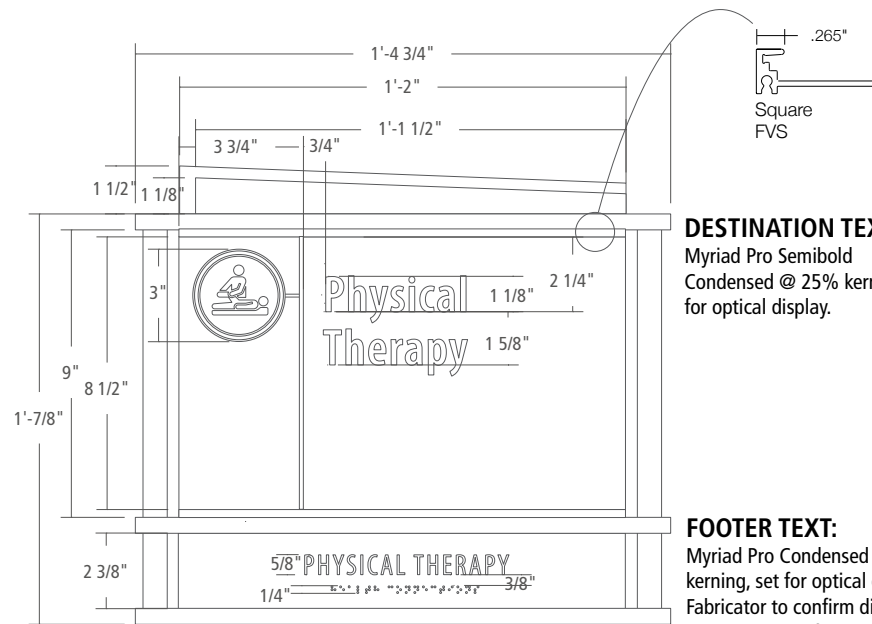

**DESTINATION TEXT:**  
Myriad Pro Semibold  
Condensed @ 25% kerning, set  
for optical display.

**FOOTER TEXT:**  
Myriad Pro Condensed @ 75%  
kerning, set for optical display.  
Fabricator to confirm dimensions with  
ADA Standards for Accessible Design.

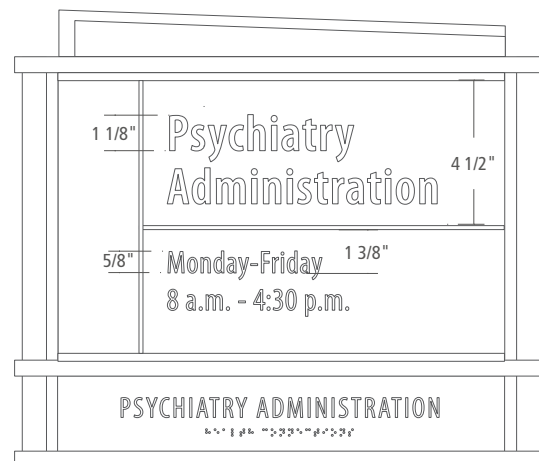
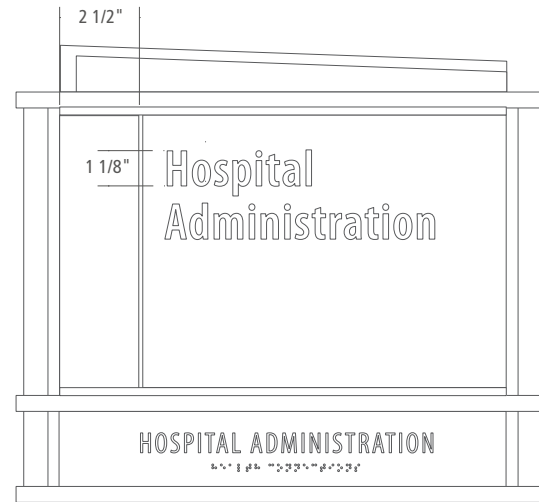

**HOURS OF OPERATION TEXT:**  
Myriad Pro Condensed @ 25% kerning, set for optical display.

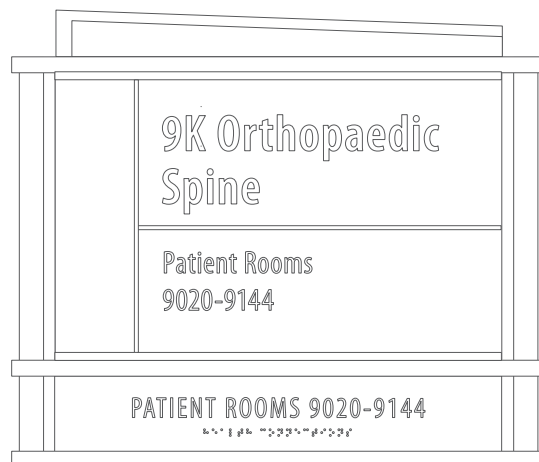

**PATIENT ROOMS TEXT:**  
Myriad Pro Condensed @ 25% kerning, set for optical display.



**“(OCTRI)” TEXT:**  
Myriad Pro Condensed @ 25% kerning, set for optical display.

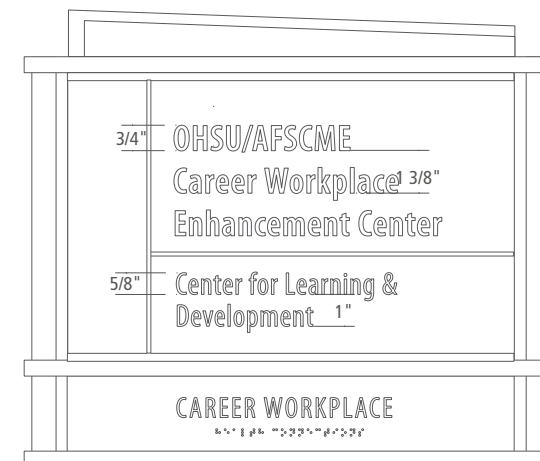

**“(Center for...)” TEXT:**  
Myriad Pro Condensed @ 25% kerning, set for optical display.

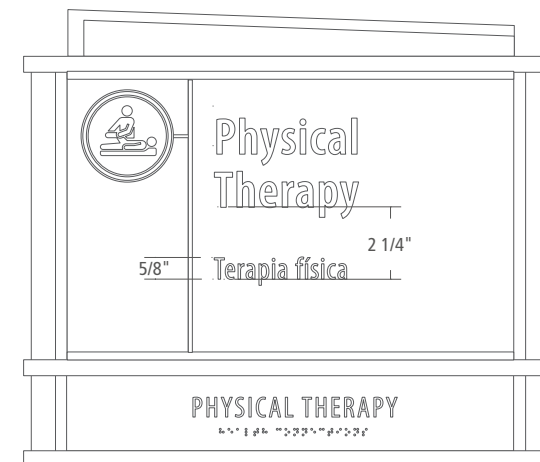

**PATIENT ROOMS TEXT:**  
Myriad Pro Semibold Condensed @ 25% kerning, set for optical display.

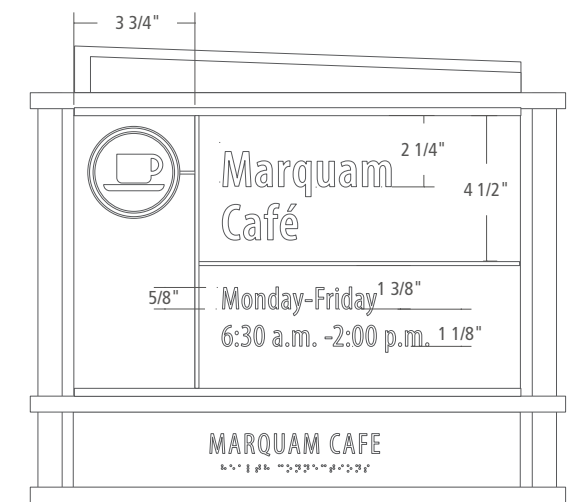

**HOURS OF OPERATION TEXT:**  
Myriad Pro Condensed @ 25% kerning, set for optical display.



**I-1 PRIMARY ID, DECORATIVE DETAIL**  
Scale: 2"=1'-0" on an 11" x 17" sheet

**I-1a PRIMARY ID, w/SLIDER, DECORATIVE DETAIL**  
Scale: 2"=1'-0" on an 11" x 17" sheet

**IN-USE SLIDER:**

APCO in-use slider integrated into sign frame assembly. Slider should be the same width of sign cabinet so edges of the bar are flush with the edges of the sign cabinet.

To match thickness of APCO sign frame

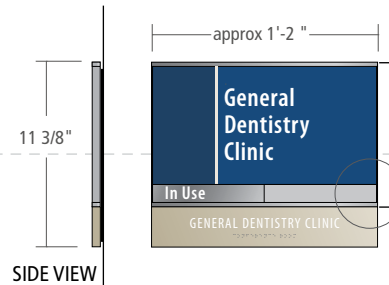

Insert without symbol

**BACKER PLATE:**

1/8" thick acrylic panel mounted to the wall.

**CABINET:**

APCO FullView Standard Assembly - horizontal configuration, FVS8514(H). Sign frame is mounted to acrylic panel backer plate. Sign is mounted on side for access to release pin. Large format printed insert sits behind matte acrylic lens. Insert should fit tight against acrylic window for optimal appearance. Sign components are surface flush. Window is removed from frame with a suction cup tool using a lift/pull technique.

**FOOTER:**

Acrylic panel with tactile and Braille characters. Tactile letters painted white, Braille painted background color. Panel thickness to equal thickness of APCO sign frame. Panel is mounted to backer panel. Sign components are surface flush.

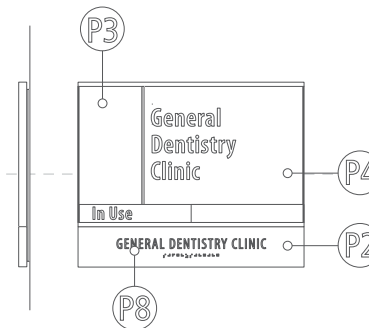

**I-1ca PRIMARY ID w/SLIDER**

Scale: 1"=1'-0" on an 11" x 17" sheet

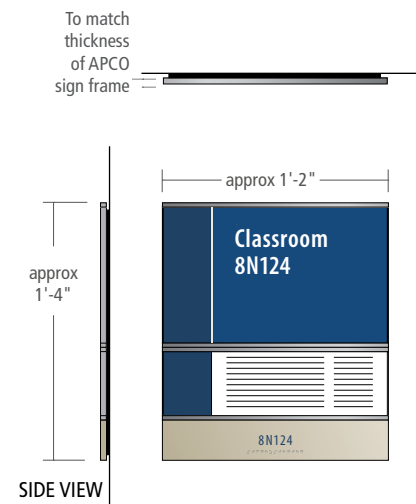

**BACKER PLATE:**  
Constructed from 1/8" (th.) acrylic.

**SIGN FRAME:**  
APCO FullView FVS8514(H)MF - horizontal configuration, pin to be installed in the upper left position, mounted to acrylic panel. Large format printed insert sits behind matte acrylic lens. Insert should fit tight against acrylic window for optimal appearance. Window is removed from frame with a suction cup tool using a lift/pull technique.

**INSERT FRAME:**  
APCO FullView FVS0414(IA)MF - to allow for 8 1/2" x 11" changeable notice. Frame is mounted to acrylic backer panel. Left side of holder to be filled with painted acrylic panel separated from insert holder by a blocking strip. Notice is changed by inserting a sticky note or similar between the display and non-glare lens then pulling the notice up/out of the frame.

**FOOTER:**  
Acrylic panel with tactile and Braille characters. Tactile letters and Braille painted background color. Panel thickness to equal thickness of APCO sign frame. Panel is mounted to backer panel.

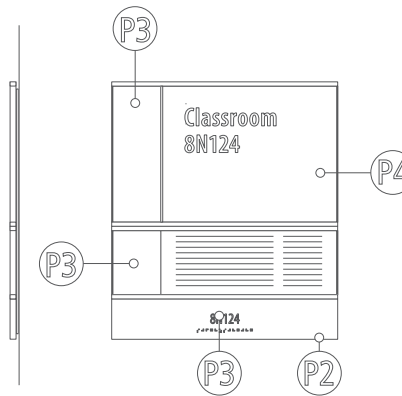

**I-1d CLASSROOM/LAB ID w/ INSERT**  
Scale: 1"=1'-0" on an 11" x 17" sheet

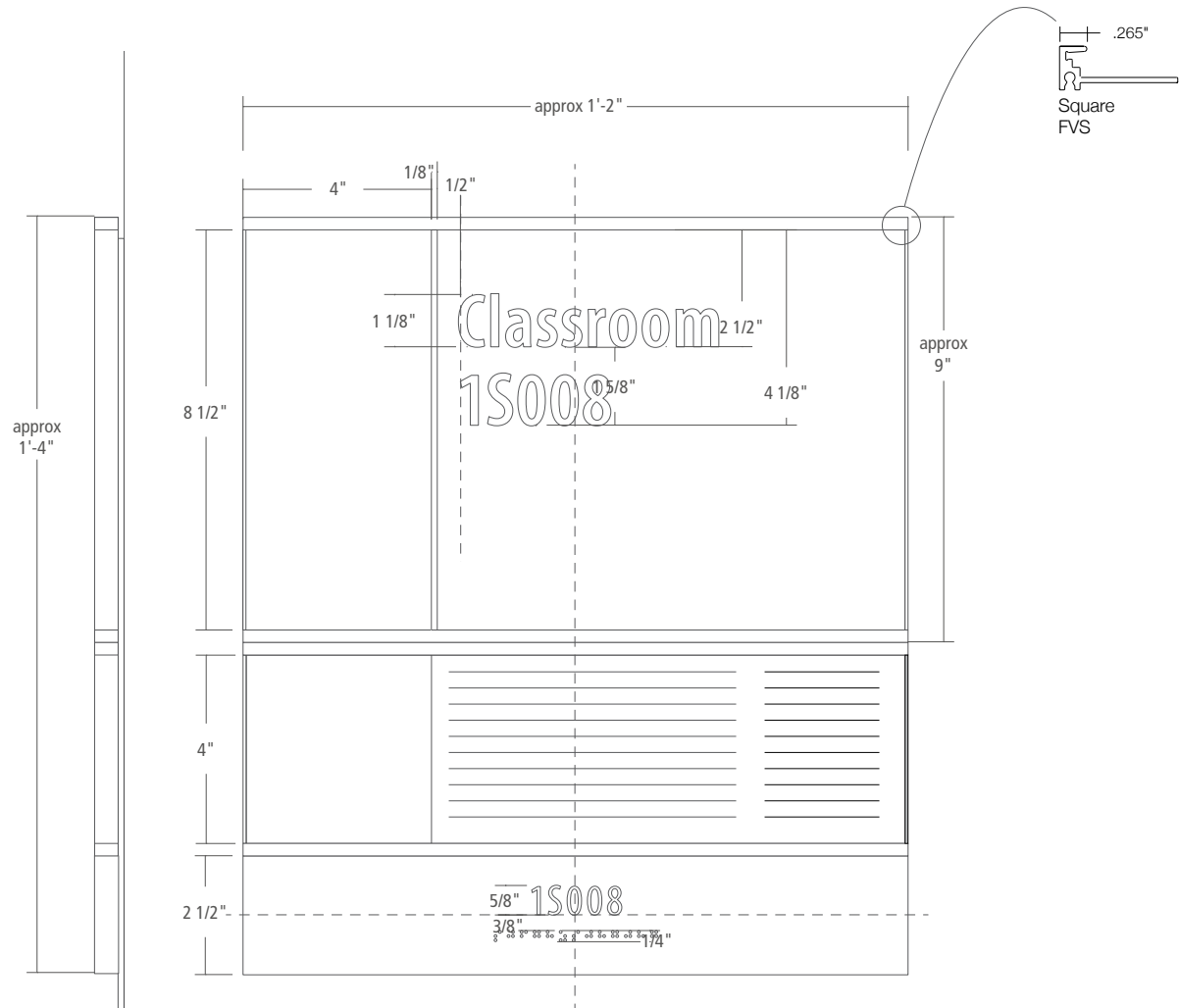

Scale: 3" = 1'-0"

**DESTINATION TEXT:**  
Myriad Pro Semibold  
Condensed @ 20% kerning, set  
for optical display.

**FOOTER TEXT:**  
Myriad Pro Condensed @ 75%  
kerning, set for optical display.  
Fabricator to confirm  
dimensions with ADA  
Standards for Accessible  
Design.

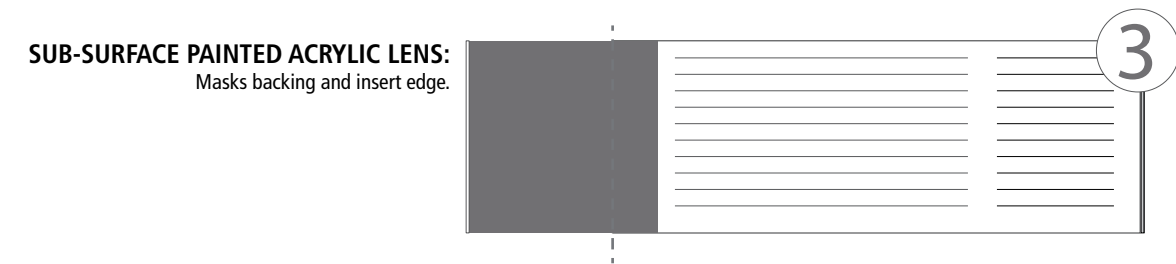
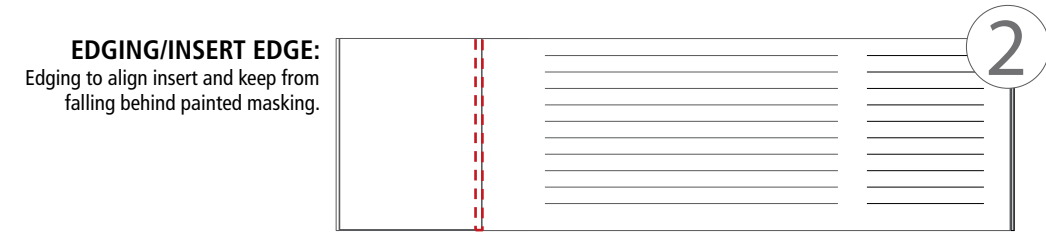
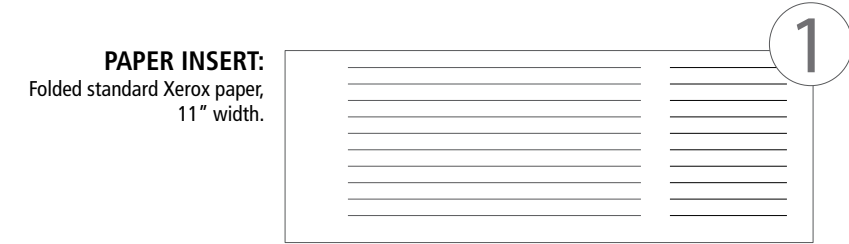
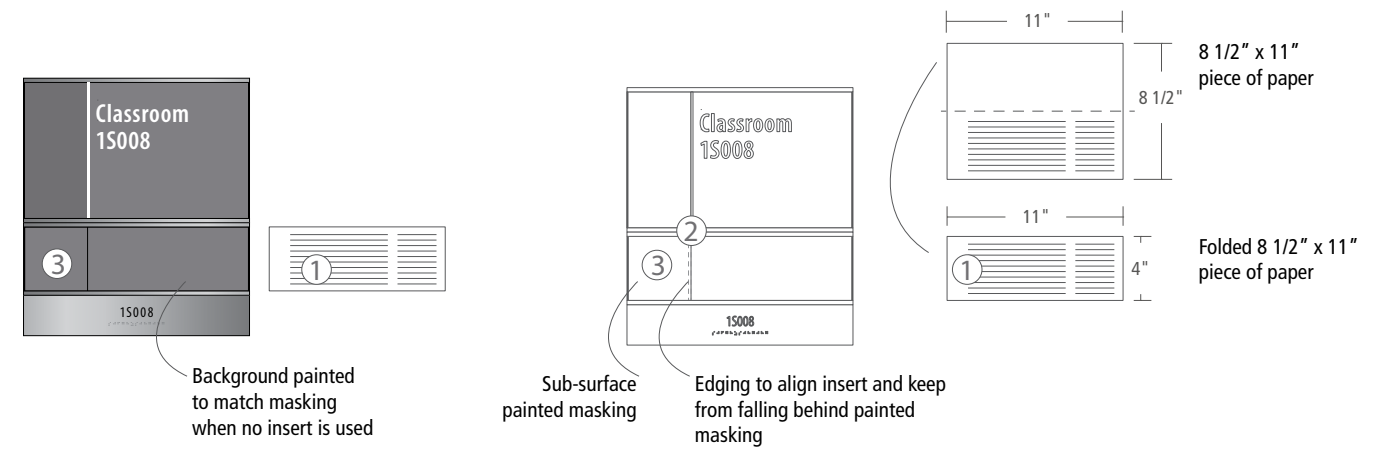

**I-1d CLASSROOM/LAB ID w/ INSERT**  
SPECIFICATION DETAILS  
Scale: 3" = 1'-0"



**NOTE:**  
Use of this sign type must be approved by the Chief Marketing Officer.



**LOGO ON A DARK BACKGROUND:**  
1/4" (th.) brushed aluminum (horizontal grain) logo.

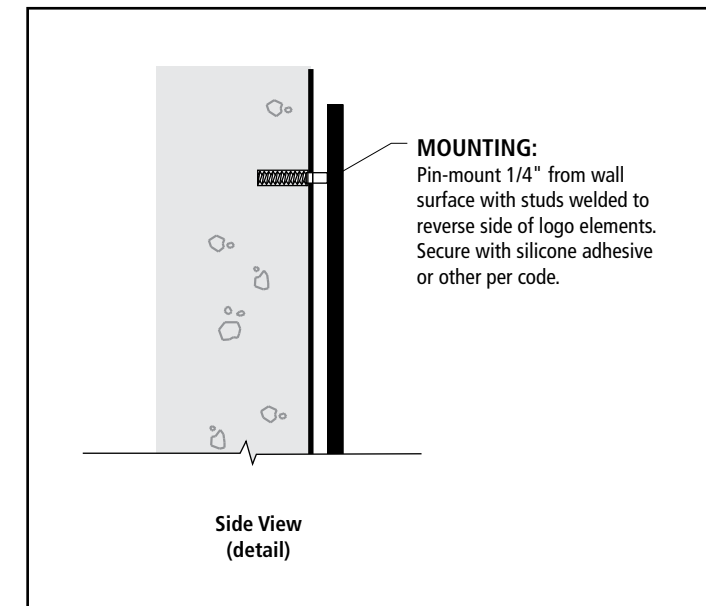

**I-8 LOGO**  
Scale: 1"=1'-0" on an 11" x 17" sheet

**O-5c OVERHEAD GUIDE, DOUBLE-SIDED, PROJECTION MOUNTED**

Suspended overhangs use Carl Stahl I-Sys® Edelstahl-Seilsystem Stainless Steel Wire Rope System. Fork with internal thread (#817-0500) and threaded M5 cable for mounting.

1" x 1/2" aluminum U channel painted to match Metallic Silver

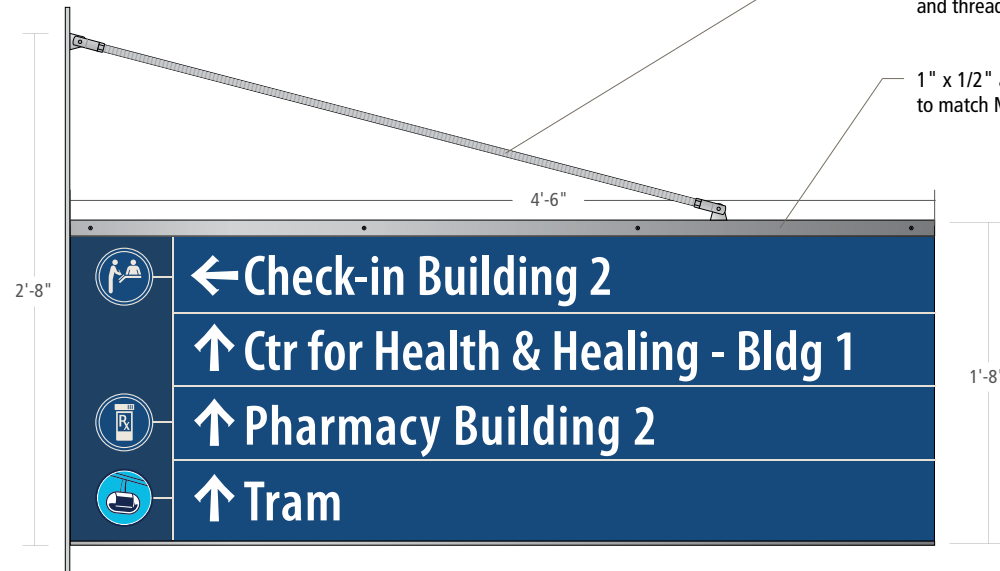

SIDE A



SIDE B

**SIGN:**

Message panels are fabricated from 1/2" (th.) painted Komacel panels with APCO aluminum mounting bracket with square profile. Sign edges to be painted to match face. Messaging to be surface applied vinyl graphics. Sign bottom edge to have break-formed aluminum trim fabricated from .090 (th.) aluminum.

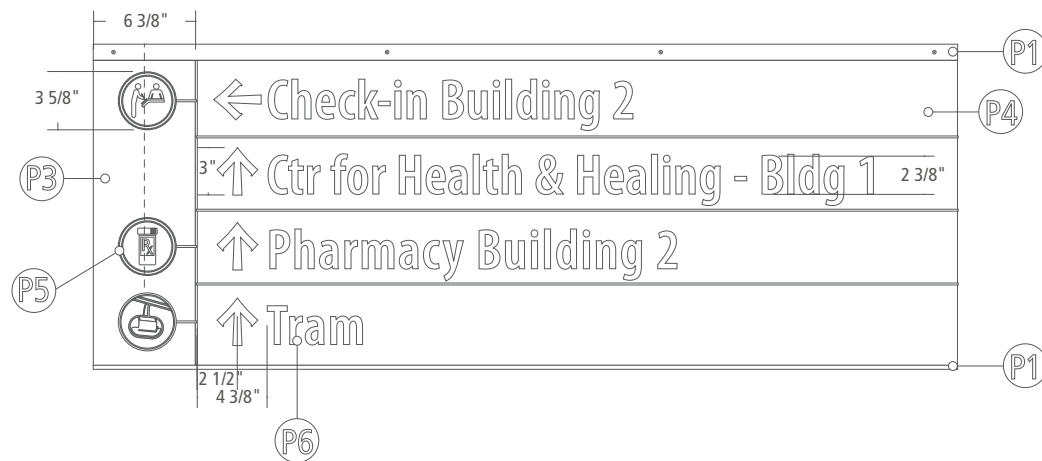

**FONT:**  
Myriad Pro SemiBold  
Condensed @ 25% kerning.

**NOTE:**  
An ampersand is acceptable in Center for Health & Healing because it's part of the official name.

**O-5c OVERHEAD GUIDE, DOUBLE-SIDED, PROJECTION MOUNTED**

Scale: 1" = 1'-0" on an 11" x 17" sheet

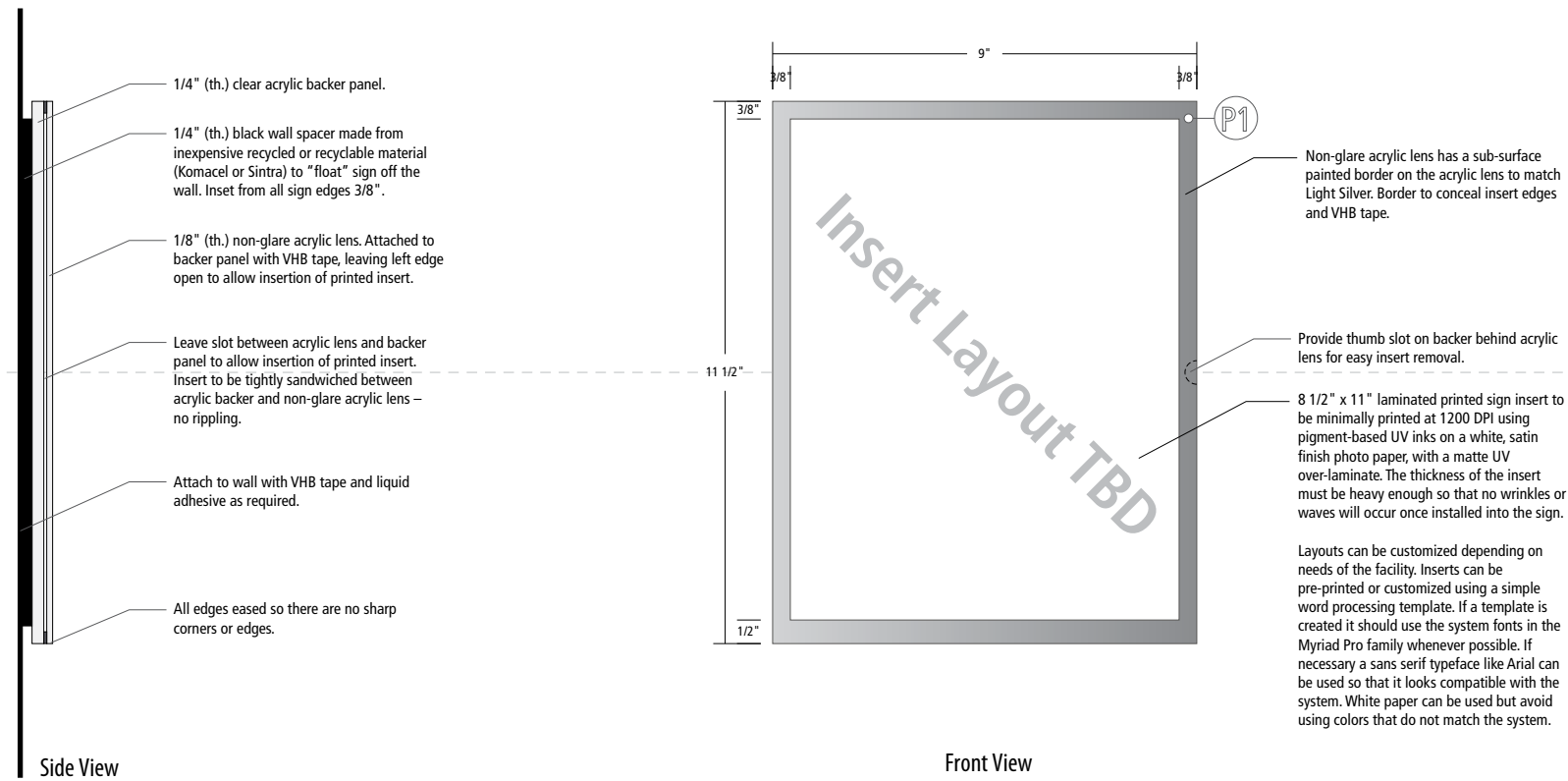

**N-1d-alt NOTICE HOLDER, LETTER PORTRAIT, ACRYLIC**  
 Scale: 3"=1'-0" on an 11" x 17" sheet

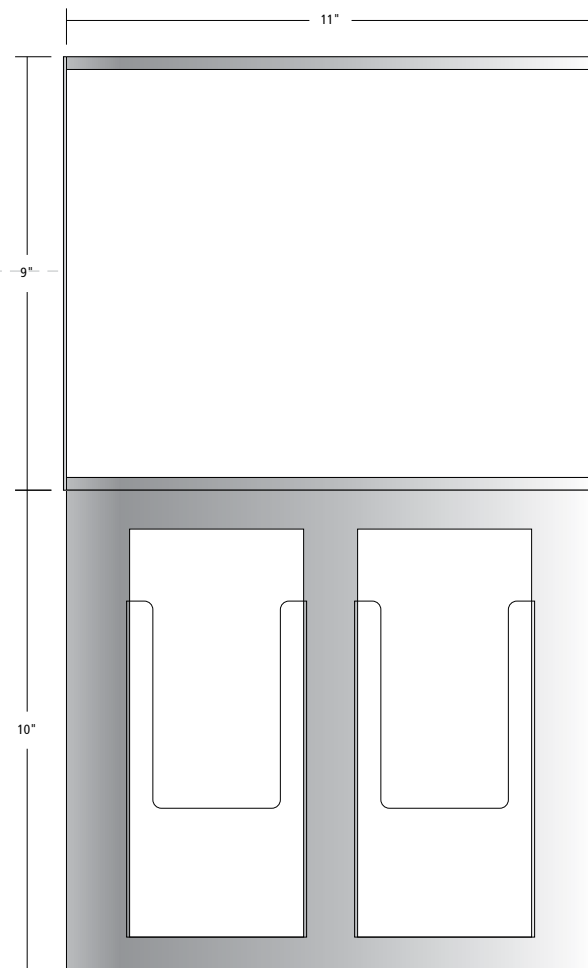

**SIGN FRAME:**

APCO FullView FVS8511(H) sign.  
Custom-printed 11" x 8 1/2" insert  
sits behind matte acrylic lens.

**SIGN BACKER:**

1/4" (th.) sign backer to extend  
below sign frame. Paint to match  
Silver.

**BROCHURE HOLDERS:**

Mount two brochure holders to  
sign backer below sign frame.  
Suggested brochure holder: Slim  
Pocket Brochure Holder - for Wall  
Mounted 3-3/4 wide Trifold  
Literature - See more at:  
<http://www.display-world.com>.

**N-1h NOTICE HOLDER W/BROCHURE HOLDERS**

Scale: 3"=1'-0" on an 11" x 17" sheet

