

Outpatient Health Care Usability Profile V3

Drum, C.E., Davis, C.E., Berardinelli, M., Cline, A., Laing, R., Horner-Johnson, W., & Krahn, G.



© Copyright 2008 Oregon Health & Science University RRTC: Health & Wellness

Funded by the National Institute on Disability and Rehabilitation Research Office of Special Education and Rehabilitative Services, U.S. Department of Education. Grant NumberH133B040034.

Graphic images used with permission from the Kentucky Department of Vocational Rehabilitation.

RRTC: Health & Wellness
Oregon Institute on Disability and Development
707 SW Gaines Street
Portland, OR 97239
(voice) 503-494-3534
Relay 7-1-1
rrtc@ohsu.edu
healthwellness.org



Contents

Instructions for using the OHCUP	2
Section 1: Patient Arrival.....	3
Parking	3
Approach to building.....	4
Ramps	6
Signage	7
Controls.....	10
Doors.....	11
Section 2: Public Facilities	13
Telephones	13
Seating.....	15
Counters.....	15
Passageways	16
Water Fountains.....	18
Lifts.....	19
Elevators	20
Stairs	23
Rest Rooms.....	24
Emergency Egress.....	31
Section 3: Exam Rooms and access to Primary Services	33
Appendix A: Parking Requirements	41
Appendix B: Overall Scoring Sheet.....	42
Appendix C: Mobility Scoring Sheet.....	47
Appendix D: Sensory Scoring Sheet.....	51
Appendix E: Cognitive Scoring Sheet.....	54

Instructions for using the OHCUP

This checklist was designed to measure the usability of primary care clinics for people with disabilities. Please note the distinction between **accessibility** as defined by the Americans with Disabilities Act and **usability** as defined by the RRTC: Health & Wellness. Accessibility means that a clinic meets each and every standard set by the ADA Accessibility Guidelines (ADAAG). Usability means that a clinic meets enough of those standards to be usable for people with different types of disabilities, specifically mobility, sensory and cognitive impairments. By this rationale, a clinic can be usable for someone with a sensory impairment but not for someone with a mobility impairment.

General instructions

There are three sections in the OHCUP: Patient Arrival, Public Facilities and Exam Rooms and Access to Primary Services. Each section has several sub-sections with specific instructions for which particular area of the clinic the following items should be considered. For example, in the Approach to Building subsection, you will be considering the route from the parking area to the entrance of building only.

Within each section, each item should be judged independently from the other items. You will answer either YES, NO, or N/A (not applicable) for each item. Some sections will be irrelevant in some clinics. For example, if there were no lifts in the clinic, each question in that section would be considered N/A. Some items offer further instructions to assist you in making a determination. Other items offer advice on how best to take measurements. Graphics have been included to provide a visual cue for taking measurements.

About scoring

There is a scoring sheet at the end of the checklist for this purpose. A YES or N/A response will count as “usable” and a NO response will count as “not usable.” You will enter every YES or N/A answer, divide by the total number of items and multiply by 100 for your score. There are scoring sheets at the end of this checklist with further instructions. You can also obtain an electronic scoring sheet by contacting OHSU’s Rehabilitation Research and Training Center at rrtc@ohsu.edu.

This checklist is NOT a substitute for federal accessibility guidelines and/or the appropriate state and local building codes.

For more information

The Americans with Disabilities Act Accessibility Guidelines can be found at the Access Board Website: www.access-board.gov/gs.htm

Section 1: Patient Arrival

Parking

This subsection applies to the designated clinic parking area only. For example, you would consider only the basement parking area of a building's garage (even if there is street-level access) if that is where the usable parking is located.

1. The required number of designated parking spaces displaying the symbol shown to the right are provided (see Appendix A).
- Yes
 No
 N/A



2. At least one in every eight designated parking spaces is van accessible.
- Yes
 No
 N/A

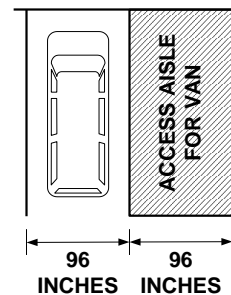

3. There are 98 inches of vertical clearance available for lift-equipped vans.
- Yes
 No
 N/A

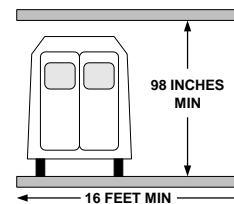

4. All designated parking spaces are on the shortest route of travel to the building's accessible entrance.
- Yes
 No
 N/A

Note: You may have to ask what the clinic considers their "accessible" entrance.

-
5. Access aisle surfaces between designated spaces are firm, stable, and slip resistant.
- Yes
- No
- N/A
-

6. In designated passenger loading zones, there is an access aisle at least 5 feet wide and 20 feet long adjacent and parallel to a vehicle pull-up space.
- Yes
- No
- N/A

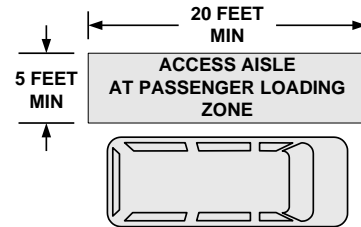

Note: May be marked "Patient Drop-Off" with signs or have painted stripes. If no identifiable zone, then mark N/A.

7. Curb ramps in the parking area have a smooth transition from the ramp to the passageway.
- Yes
- No
- N/A
-

Approach to building

This subsection applies from parking area to entrance of building.

8. The route of travel does not require the use of stairs.
- Yes
- No
- N/A
-

9. The surface of the route of travel is stable, firm, and slip-resistant.
- Yes
- No
- N/A
-

10. The route leading to the building is at least 36 unobstructed inches wide.

- Yes
- No
- N/A

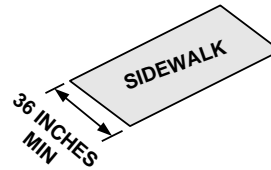

11. All curbs on the route of travel have curb ramps.

- Yes
- No
- N/A

Note: If no curbs, then write N/A. Ramp should have/be: Slope is less than 1:12 (measured at steepest point), stable, firm, and slip resistant, 36 inches wide exclusive of flared sides. If ramp does not meet these criteria, mark NO.

12. Where there are stairs at the main entrance, there is either a ramp, lift, or an alternative entrance provided.

- Yes
- No
- N/A

13. When alternative entrances are used, there is a sign at the main entrance indicating the location of the alternative entrance.

- Yes
- No
- N/A



14. Alternative entrances can be used without assistance.

- Yes
 - No
 - N/A
-

15. The entrance door has at least 32 inches clear opening (for a double door, at least one leaf has a 32-inch clear opening).

- Yes
- No
- N/A

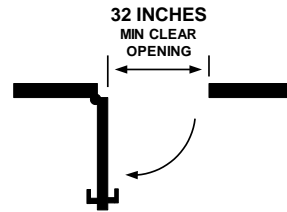

16. There is at least 18 inches of clear, unobstructed wall space.

- Yes
- No
- N/A

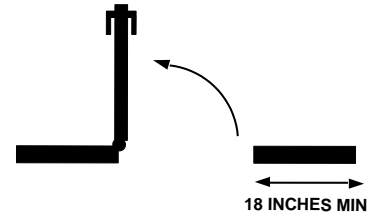

Note: If the door is automatic, mark N/A.

17. All threshold edges are 1/4 inch high or less, or if beveled edge, no more than 1/2 inch high.

- Yes
- No
- N/A

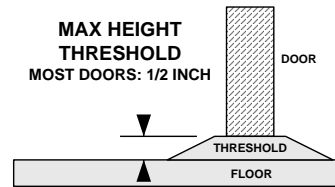

Ramps

This subsection applies to ramps where they exist along the path of travel.

18. The slope of a ramp (rise over run) should be no greater than 1:12.

- Yes
- No
- N/A

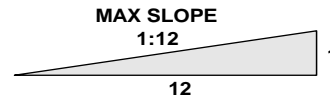

19. The surface of the ramp is stable, firm, and slip resistant.

- Yes
- No
- N/A

20. The unobstructed width of the ramp is 36 inches.

- Yes
- No
- N/A

21. Any ramp that rises more than 6 inches or is longer than 72 inches has handrails on both sides.

- Yes
- No
- N/A

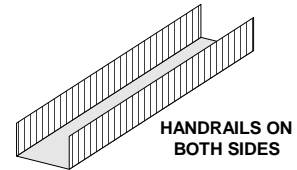

22. The top of the handrail is between 34 and 38 inches above the ramp surface.

- Yes
- No
- N/A

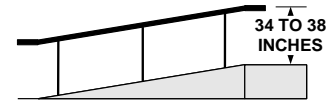

23. When the ramp changes direction, there is a level landing of at least 60 by 60 inches.

- Yes
- No
- N/A

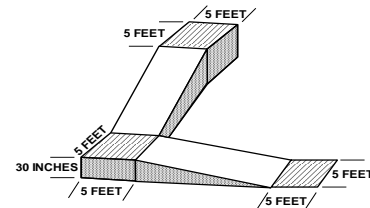

Signage

This subsection applies to signs with informational or directional signage only, e.g., those used to get to and navigate within the clinic. This excludes "exit" signs.

For questions 24-26, measure signs along path of travel from building entrance to clinic entrance, and within clinic itself.

24. If mounted above 80 inches, characters on signs that provide directions and information have letters at least 3 inches high.

Yes
 No
 N/A

25. If mounted above 80 inches, characters on signs that provide directions and information have high contrast.

Yes
 No
 N/A

26. If mounted above 80 inches, characters on signs that provide directions and information have a non-glare finish.

Yes
 No
 N/A

For questions 27-34, measure signs within clinic only.

27. Signs designating rooms and spaces are mounted with centerlines 60 inches from floor.

Yes
 No
 N/A

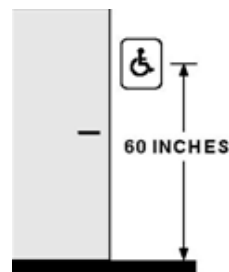

Note: Measurement of 60 inches can be taken from anywhere on sign (top, middle, or bottom).

28. Signs designating rooms and spaces are mounted on the wall adjacent to or as close as possible to the latch side of the door.

- Yes
- No
- N/A

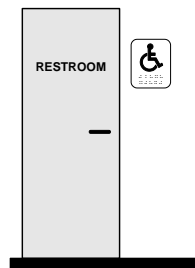

29. Signs designating rooms and spaces have characters and background with a non-glare finish.

- Yes
- No
- N/A

30. Signs designating rooms and spaces have raised characters.

- Yes
- No
- N/A

31. Signs designating rooms and spaces have high contrast.

- Yes
- No
- N/A

32. Signs designating rooms and spaces have Braille text.

- Yes
- No
- N/A

33. When a pictogram is used to designate rooms and spaces, it is accompanied by raised characters and Braille.

- Yes
 - No
 - N/A
-

34. If signs designating rooms and spaces do not have raised characters, Braille, or pictograms, there is other directional assistance available (i.e. sound recordings, or a receptionist nearby).

Yes
 No
 N/A

Note: If any of the answers to Questions 24 -33 are NO or N/A, then answer this question. If all are YES, then answer N/A.

For question 35, measure sign at clinic entrance only.

35. Sign at entrance to clinic has height of 60 inches to centerline, high contrast, raised and Braille characters, and non-glare finish.

Yes
 No
 N/A

Controls

This subsection applies to controls such as light switches, door handles, etc.

36. All controls that are available to the public are located no higher than 48 inches.

Yes
 No
 N/A

37. All controls that are available to the public are operable with a closed fist.

Yes
 No
 N/A

Doors

This subsection applies to doors within the clinic building, excluding the entrance door.

38. When a door is opened to 90 degrees, there is a clear opening width of at least 32 inches measured between the face of the door and the doorstop on the latch side.

- Yes
- No
- N/A

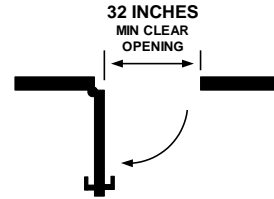

39. Clear space between doors in a series is at least 48 inches.

- Yes
- No
- N/A

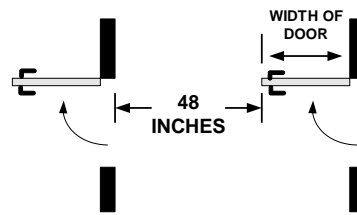

Note: If both doors are automatic, then mark N/A

40. There is at least 18 inches of clear wall space on the pull side of doors.

- Yes
- No
- N/A

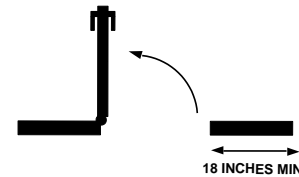

Note: Judge doors from waiting room to exam room/ lab restroom on the path of travel only.

41. The operating hardware is mounted no higher than 48 inches above the floor.

- Yes
- No
- N/A

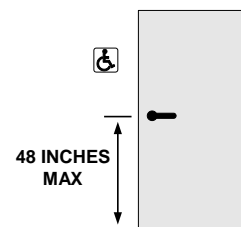

Note: If door opens automatically with a sensor, enter N/A.

42. All handles, locks, and latches or other opening hardware are operable with a closed fist.

- Yes
- No
- N/A

43. All threshold edges are 1/4 inch high or less, or if beveled edge, no more than 1/2 inch high.

- Yes
- No
- N/A

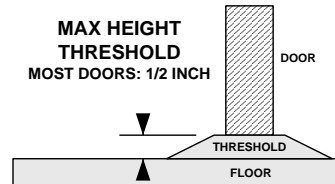

Section 2: Public Facilities

Telephones

This subsection applies to any phones available for public use along path of travel.

44. The designated telephone has at least 30 by 48 inches of clear floor space.

- Yes
- No
- N/A

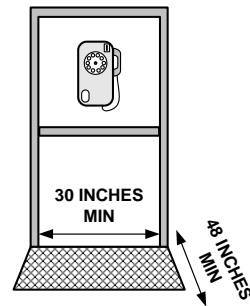

45. The route to the telephone is at least 36 unobstructed inches wide adjoining or overlapping the clear floor space.

- Yes
- No
- N/A

46. The highest operable part of the phone is no higher than 48 inches.

- Yes
- No
- N/A

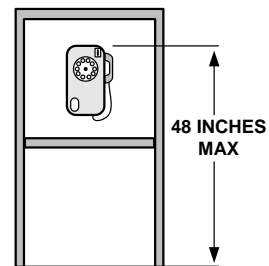

47. If a wall-mounted telephone has a leading edge between 27 and 80 inches from the floor, it projects less than 4 inches into the pathway.

- Yes
- No
- N/A

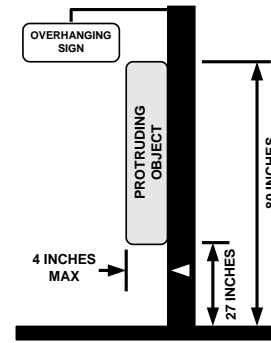

Note: Enter YES if telephone is recessed and not projecting into passageway.

48. The designated phone is hearing aid compatible.

- Yes
- No
- N/A

49. The designated phone is adapted with volume control.

- Yes
- No
- N/A

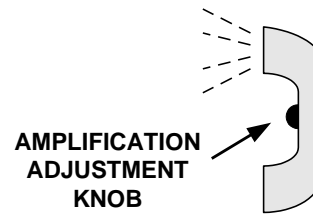

50. Volume controlled telephones are identified by a sign showing a handset radiating sound waves.

- Yes
- No
- N/A

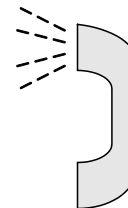

51. When telephone banks do not contain a text telephone (TTY), there is a sign to indicate location of nearest TTY.

- Yes
- No
- N/A

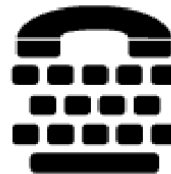

Seating

This subsection applies to seating in the waiting area only.

52. All aisles between seating are at least 36 unobstructed inches wide.
- Yes
- No
- N/A
-

Counters

This subsection applies to counters along the path of travel.

53. The tops of tables or counters are between 28 and 34 inches high.
- Yes
- No
- N/A

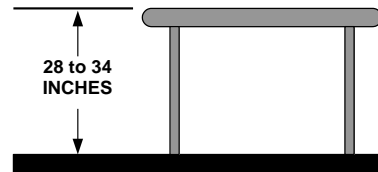

54. When tables are provided (excluding end tables), at least one has knee space of at least 27 inches high, 30 inches wide and 19 inches deep.
- Yes
- No
- N/A

For example, a checkout area that has a seat for clinic personnel and a seat for patients is a table.

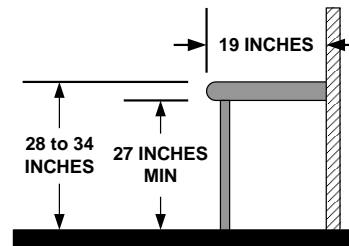

Passageways

This subsection applies to the route of travel to clinic services excluding doorways.

55. All passageways are at least 36 unobstructed inches wide.

- Yes
 No
 N/A

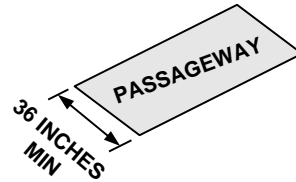

Note: If temporary objects protrude into passageway, then measure passageway to edge of object.

56. If the passageway is less than 60 inches wide, there are passing spaces at least 60 inches wide and 60 inches long or intersecting walks allowing passing at reasonable intervals not exceeding 200 feet.

- Yes
 No
 N/A

Note: If passageway is more than 60 inches wide, mark N/A.

57. There is a 5 foot circle or T-shaped space (36 inches wide each direction and 60 inches minimum depth) to reverse direction.

- Yes
 No
 N/A

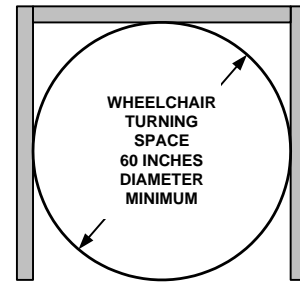

Note: This is a difficult measurement to make. It may require 2 people working together to make an accurate reading. Study the diagram closely, and take your time making your measurement.

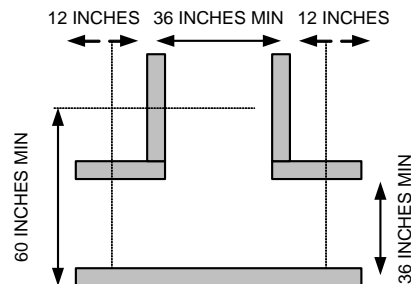

58. Where a passageway makes a U-turn around an obstacle that is less than 48 inches wide, the passageway width increases to at least 42 inches on the approaches and 48 inches in the turn.

- Yes
- No
- N/A

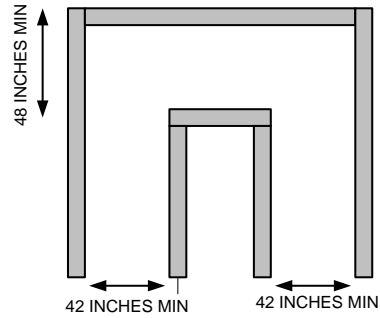

59. If passageway levels change, the vertical difference is less than 1/4 inch, or if the change in level is between 1/4 and 1/2 inch, there is a beveled edge with a slope no greater than 1:2.

- Yes
- No
- N/A

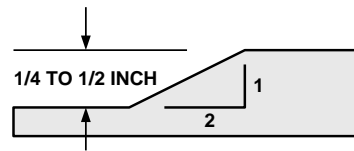

60. Objects mounted on the wall that have leading edges between 27 inches and 80 inches from the floor project less than 4 inches into the passageway.

- Yes
- No
- N/A

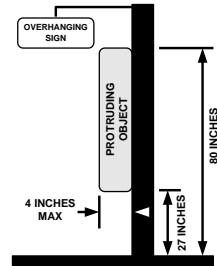

61. Carpeting is low-pile, tightly woven and securely attached along edges.

- Yes
- No
- N/A

62. In passageways through public areas, all obstacles (e.g. fire extinguishers) are located within 27 inches of the floor or higher than 80 inches and protrude less than 4 inches from the wall.

- Yes
- No
- N/A

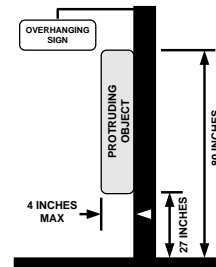

Water Fountains

This subsection applies to water fountains where they exist along the path of travel.

63. Where fountains are provided, there is a clear floor space of at least 30 by 48 inches.

Yes

No

N/A

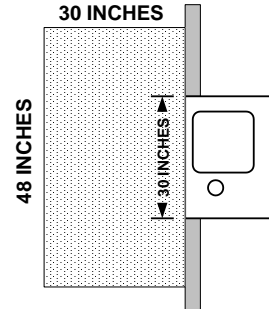

64. When fountains are provided, there is at least one fountain with its spout fixture no higher than 36 inches from the floor.

Yes

No

N/A

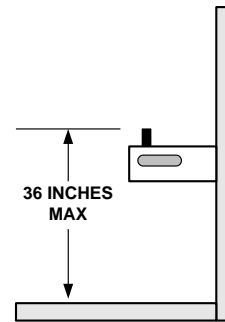

65. If a wall-mounted fountain has a leading edge between 27 and 80 inches from the floor, it projects less than 4 inches into the pathway.

Yes

No

N/A

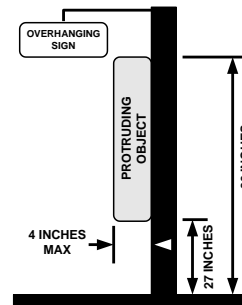

Note: Enter YES if fountain is recessed and not projecting into passageway.

Lifts

This subsection applies to lifts when provided along the path of travel.

66. Where a lift is provided, it is usable without assistance.
- Yes
 No
 N/A
-

67. If the lift is not usable without assistance, a call button is provided.
- Yes
 No
 N/A
-

68. The lift controls are operable with a closed fist.
- Yes
 No
 N/A
-

69. There is at least 30 by 48 inches of clear floor space outside the lift.
- Yes
 No
 N/A
-

70. The lift controls are located no higher than 48 inches.
- Yes
 No
 N/A
-

71. The floor surface of the lift is slip-resistant and any change in level is less than 1/4 inch.
- Yes
 No
 N/A
-

Elevators

This subsection applies to elevators where they exist along the path of travel.

72. The call button has a visual signal that indicates direction of travel.

- Yes
 No
 N/A

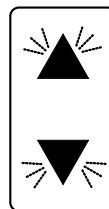

73. The call button has an audible signal that indicates direction of travel.

- Yes
 No
 N/A

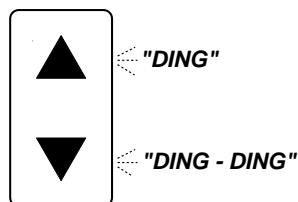

74. There are signs identifying the floor number in raised letters on both sides of the doorjamb of the elevator at every floor.

- Yes
 No
 N/A

75. There are signs identifying the floor number in Braille letters on both doorjamb of the elevator at every floor.

- Yes
 No
 N/A

76. The elevator automatically comes within 1/2 inch of the floor landing at each stop.

- Yes
 No
 N/A

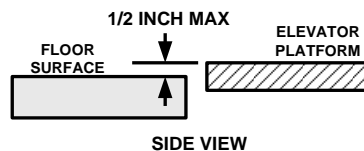

77. The elevator is large enough that a wheelchair user can enter, reach the controls and exit.

Yes

No

N/A

Note: This is a difficult measurement to make. It may require 2 people working together to make an accurate reading. Study the diagram closely, and take your time making your measurement.

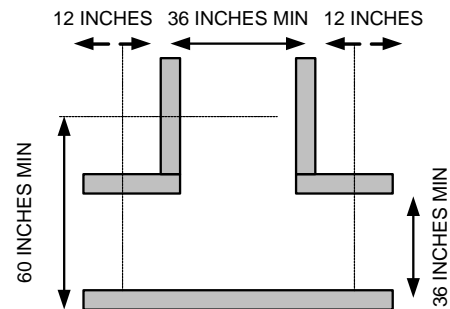
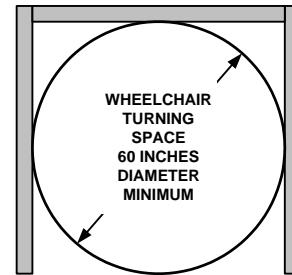

78. The elevator doors reopen automatically without contact if an object passes through the opening between 5 and 29 inches above the floor.

Yes

No

N/A

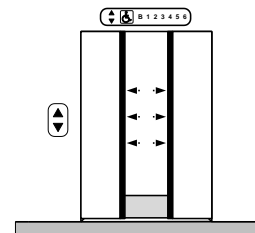

Yes

79. When reopened, it is for at least 20 seconds.

No

N/A

Yes

80. The floor buttons inside the elevator have Braille lettering.

No

N/A

81. The floor buttons inside the elevator have raised lettering.

- Yes
- No
- N/A

82. If provided, the emergency communication system (e.g. handset, intercom) is identified with Braille and raised letters.

- Yes
- No
- N/A

83. If provided, the emergency communication system (e.g. handset, intercom) is no higher than 48 inches above the floor.

- Yes
- No
- N/A

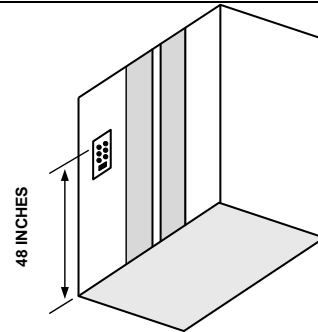

84. All elevator controls are no lower than 15 inches and no higher than 48 inches from floor.

- Yes
- No
- N/A

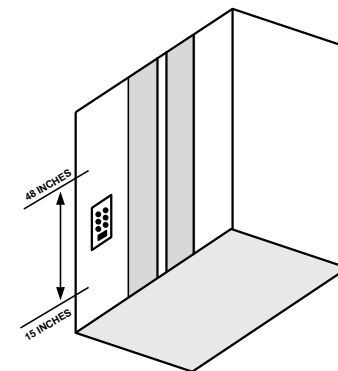

Stairs

This subsection applies to stairs where they exist along the path of travel.

85. Handrails have 12-inch extensions beyond the top riser.

- Yes
- No
- N/A

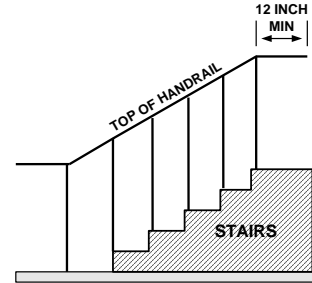

86. Handrails have 12-inch extensions beyond the bottom riser.

- Yes
- No
- N/A

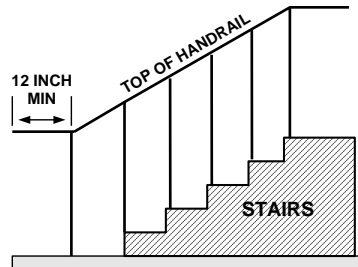

87. For stairs along the path of travel, the risers are closed.

- Yes
- No
- N/A



88. For stairs along the path of travel, the steps have uniform riser height and tread width.

- Yes
- No
- N/A

89. If there are stairs between the elevator and primary clinic services, there is a designated route without stairs.

- Yes
 - No
 - N/A
-

Rest Rooms

This subsection applies to the lobby and waiting area only. If clinic has no restrooms available to the public, enter N/A for all items in this section.

The following features are for both toilet stalls and toilet rooms.

90. Signs are mounted on the wall on the latch side of the door, 60 inches to the centerline (not on the door itself).
- Yes
- No
- N/A

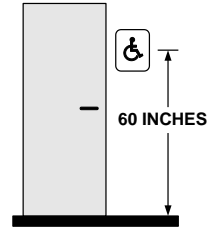

Note: Measurement of 60 inches can be taken from anywhere on sign (top, middle, or bottom).

-
91. Where pictograms or symbols are used to identify rest rooms, Braille characters are included below them.
- Yes
- No
- N/A

-
92. Where pictograms or symbols are used to identify rest rooms, raised characters are included below them.
- Yes
- No
- N/A

-
93. The restroom doorway is at least 32 inches wide.
- Yes
- No
- N/A

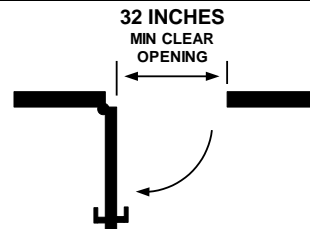

-
94. Doors are operable with a closed fist.
- Yes
- No
- N/A
-

95. Door handles are placed no higher than 48 inches.

- Yes
- No
- N/A

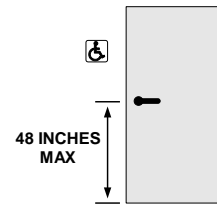

Note: Remember to check both sides of the door.

96. The entry is large enough for a wheelchair user to enter, turn around, and exit.

- Yes
- No
- N/A

Note: This is a difficult measurement to make. It may require 2 people working together to make an accurate reading. Study the diagram closely, and take your time.

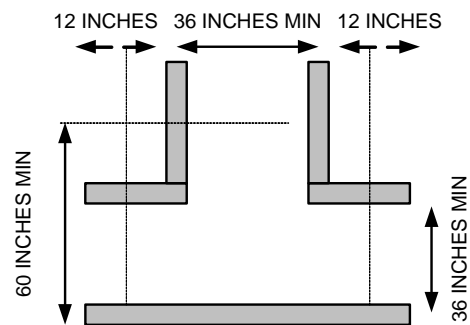
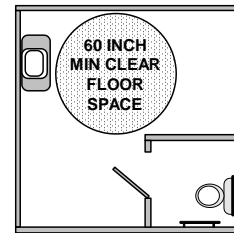

97. There is a 36-inch wide unobstructed path to all fixtures (e.g. sink, soap dispensers).

- Yes
- No
- N/A

98. The sink has a 30-inch wide by 48-inch deep clear space in front. A maximum of 19 inches of the required depth may be under the sink.

Yes
 No
 N/A

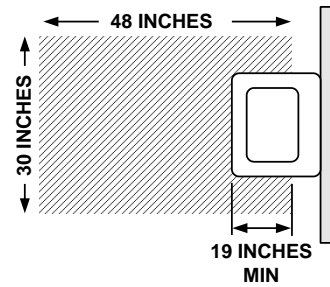

99. Pipes under the sink are covered to protect against contact.

Yes
 No
 N/A

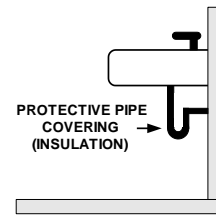

100. Where counters or tables are provided, the top is between 28 and 34 inches from the floor.

Yes
 No
 N/A

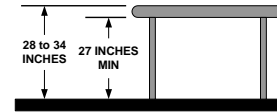

101. The sink rim is no higher than 34 inches.

Yes
 No
 N/A

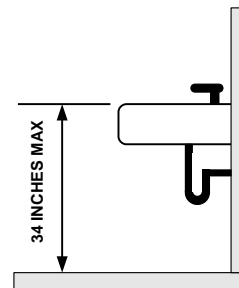

102. The faucet is operable with a closed fist.

Yes
 No
 N/A

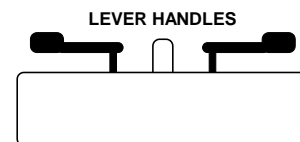

103. The highest operable part of all dispensers and hand dryers is no higher than 48 inches.

- Yes
- No
- N/A

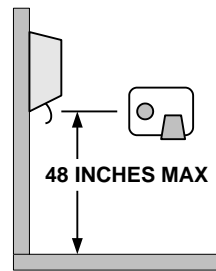

104. All dispensers and hand dryers are operable with a closed fist.

- Yes
- No
- N/A

105. The mirror is mounted with the bottom edge of the reflecting surface no higher than 40 inches.

- Yes
- No
- N/A

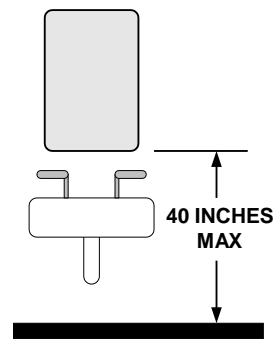

Note: This is a difficult measure to take and sometimes requires more than one measurement. Please use caution.

106. There are grab bars on the wall behind the toilet and on side wall nearest to the toilet in the designated stall/toilet room.

- Yes
- No
- N/A

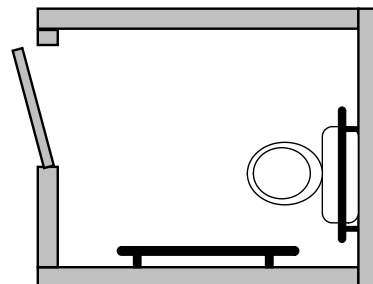

107. The toilet seat is 17 to 19 inches high.

- Yes
- No
- N/A

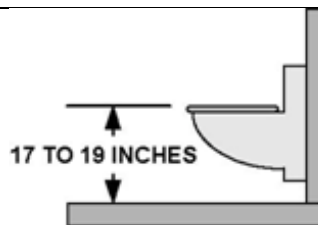

108. At all rest rooms, there is a sign indicating the location of the designated rest room(s).

- Yes
- No
- N/A



109. There is at least 18 inches of clear space from the center of the toilet to the wall(s) on either side.

- Yes
- No
- N/A

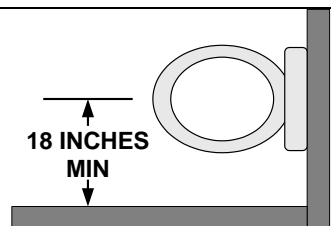

Note: Make measurement to wall. Do not include objects such as toilet paper dispensers in your measurement.

The following features are for toilet stalls.

110. All stall door hardware is operable with a closed fist.

- Yes
- No
- N/A

111. When stall door is open 90 degrees, there is at least 32 inches clear width.

- Yes
- No
- N/A

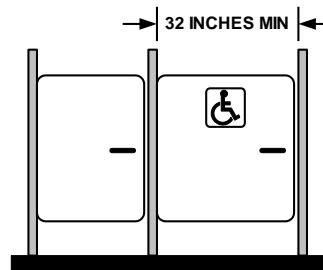

112. There is a designated stall with a clear floor space of at least 5 feet long by 5 feet wide.

- Yes
- No
- N/A

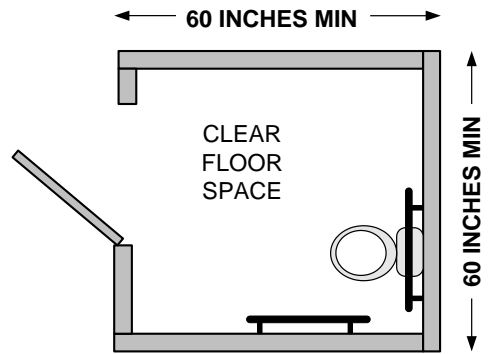

113. Where there is no stall with a clear floor space of five feet long and five feet wide, there is a stall that either 36 inches by 69 inches OR 48 inches by 69 inches.

- Yes
- No
- N/A

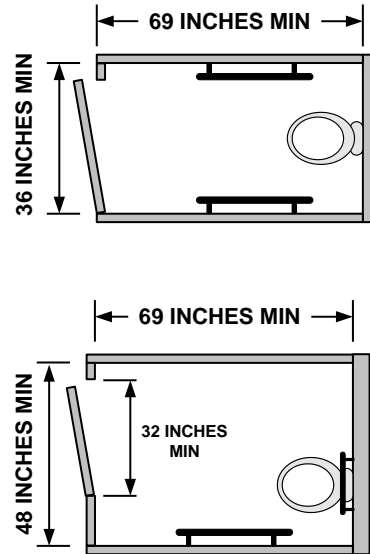

114. There is at least 18 inches of clear space at the latch side of the door.

- Yes
- No
- N/A

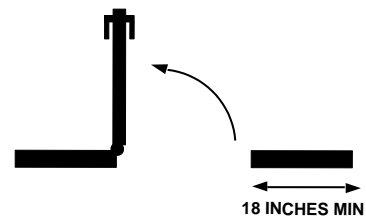

The following features are for toilet rooms.

115. Where the toilet is approached from the front and there is a sink alongside the toilet, there is clear floor space of at least 48 inches wide by 66 inches long (toilet wall to opposite wall).

- Yes
- No
- N/A

If door swings inward, measure space clear of door swing. This is easiest done with 2 people.

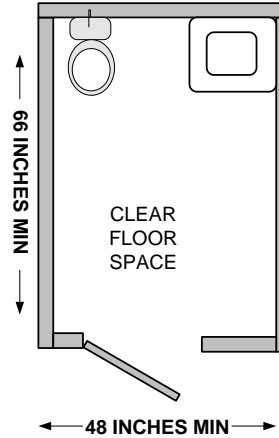

116. Where the toilet is approached from the side and there is a sink alongside the toilet, there is clear floor space of at least 48 inches wide by 56 inches long (toilet wall to opposite wall).

- Yes
- No
- N/A

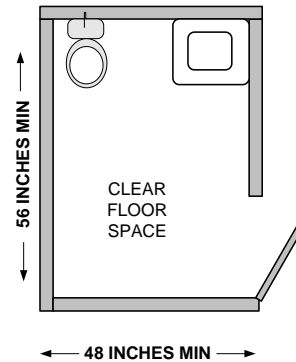

117. Where there is no sink alongside the toilet, there is a clear floor space of at least 60 inches wide by 56 inches long (toilet wall to opposite wall).

- Yes
- No
- N/A

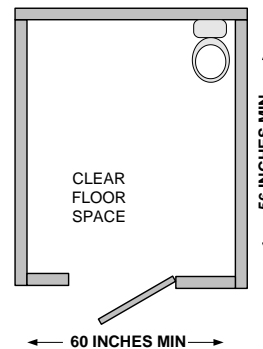

Emergency Egress

This subsection applies to the route or path for exiting in case of an emergency.

118. The emergency route is at least 36 unobstructed inches wide.

- Yes
- No
- N/A

Note: If temporary objects protrude into passageway, then measure passageway to edge of object.

119. The emergency route does not require the use of stairs.

- Yes
- No
- N/A

120. Each door along the emergency route is an accessible door.

- Yes
- No
- N/A

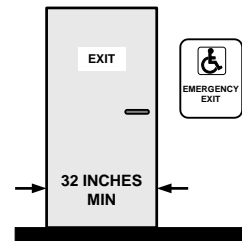

121. Where emergency alarms are provided, they have flashing lights.

- Yes
- No
- N/A

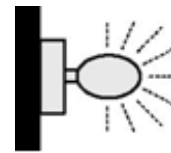

122. Where emergency alarms are provided, they have audible signals.

- Yes
- No
- N/A

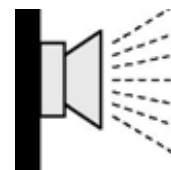

123. Where emergency alarms are provided, additional visual alarms are installed in general-use areas such as hallways, lobbies, and restrooms.

Yes
 No
 N/A

124. The visual alarms are placed 80 inches above the highest floor level within the space or 6 inches below the ceiling, whichever is lower.

Yes
 No
 N/A

125. Each area of rescue assistance provides at least 2 clear spaces no smaller than 30 by 48 inches.

Yes
 No
 N/A

Note: Areas of rescue assistance are fire-rated spaces where people unable to use stairs can wait for evacuation assistance from emergency personnel.

126. Each stairway serving an area of rescue assistance is at least 48 inches wide between handrails.

Yes
 No
 N/A

Section 3: Exam Rooms and access to Primary Services

127. There is a loaner wheelchair available.

Yes
 No
 N/A

128. There is a 36-inch passageway (excluding doorways) from the waiting area to designated exam room.

Yes
 No
 N/A

129. There is a method to weigh a wheelchair-user.

Yes
 No
 N/A

130. The clinic has at least one height adjustable exam table (lowers to 17-19 inches).

Yes
 No
 N/A

131. There is at least one lift or transfer device in exam room.

Yes
 No
 N/A

132. The designated exam room is large enough that a wheelchair user can enter, turn around, and exit.

Yes

No

N/A

Note: This is a difficult measurement to make. It may require 2 people working together to make an accurate reading. Study the diagram closely, and take your time making your measurement.

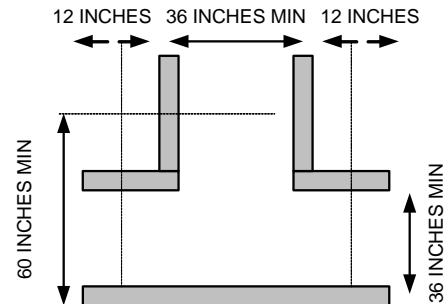
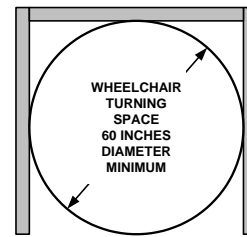

133. All controls (e.g. light switches, door handles) are operable with a closed fist.

Yes

No

N/A

134. When the door is opened to 90 degrees, there is a clear opening width of at least 32 inches measured between the face of the door and the door stop on the latch side.

Yes

No

N/A

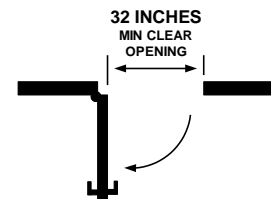

135. There are graphic charts for assessing pain for patients with cognitive disabilities.

Yes

No

N/A

Toilet rooms where lab specimens are collected should meet the following standards:

136. Signs are mounted on the wall on the latch side of the door, 60 inches to the centerline (not on the door itself).

- Yes
 No
 N/A

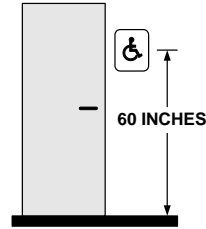

Note: Measurement of 60 inches can be taken from anywhere on sign (top, middle, or bottom).

137. Where pictograms or symbols are used to identify rest rooms, Braille characters are included below them.

- Yes
 No
 N/A

138. Where pictograms or symbols are used to identify rest rooms, raised characters are included below them.

- Yes
 No
 N/A

139. The restroom doorway is at least 32 inches wide.

- Yes
 No
 N/A

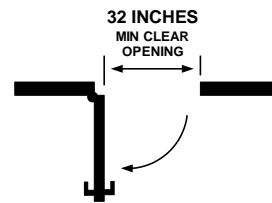

140. Doors are operable with a closed fist.

- Yes
 No
 N/A
-

141. Door handles are placed no higher than 48 inches.

- Yes
- No
- N/A

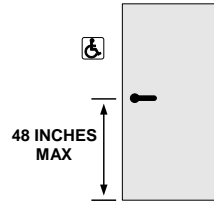

142. The entry is large enough for a wheelchair user to enter, turn around, and exit.

- Yes
- No
- N/A

Note: This is a difficult measurement to make. It may require 2 people working together to make an accurate reading. Study the diagram closely, and take your time making your measurement.

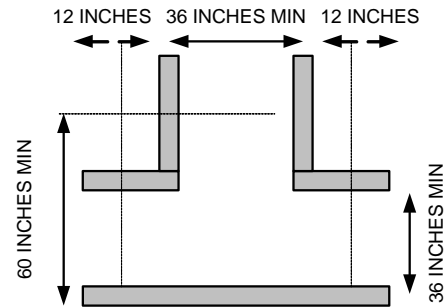
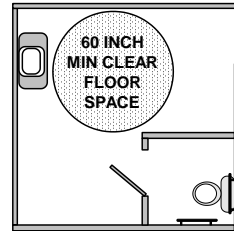

143. There is a 36-inch wide unobstructed path to all fixtures (e.g. sink, soap dispensers).

- Yes
- No
- N/A

144. The sink has a 30 inches wide by 48 inches deep clear space in front. A maximum of 19 inches of the required depth may be under the sink.

- Yes
- No
- N/A

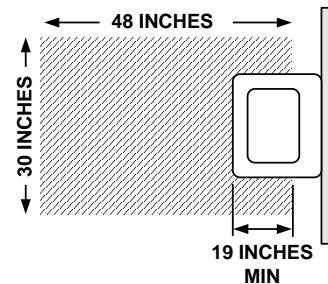

145. Pipes under the sink are covered to protect against contact.

- Yes
- No
- N/A

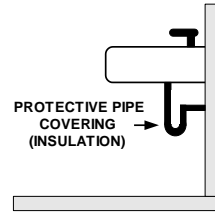

146. Where counters or tables are provided, the top is between 28 inches and 34 inches from the floor.

- Yes
- No
- N/A

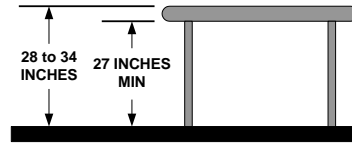

147. The sink rim is no higher than 34 inches.

- Yes
- No
- N/A

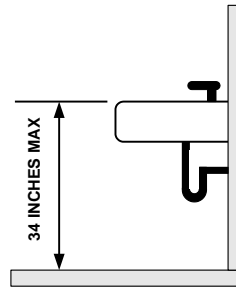

148. The faucet is operable with a closed fist.

- Yes
- No
- N/A

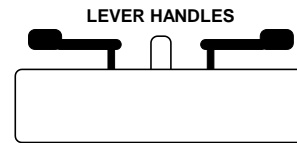

149. The highest operable part of all dispensers and hand dryers is no higher than 48 inches.

- Yes
- No
- N/A

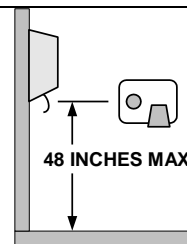

150. All dispensers and hand dryers are operable with a closed fist.

- Yes
- No
- N/A

151. The mirror is mounted with the bottom edge of the reflecting surface no higher than 40 inches.

- Yes
- No
- N/A

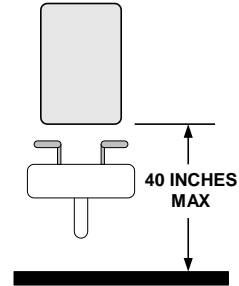

Note: This is a difficult measure to take and sometimes requires more than one measurement. Please use caution.

152. There are grab bars on the wall behind the toilet and on side wall nearest to the toilet in the designated stall/toilet room.

- Yes
- No
- N/A

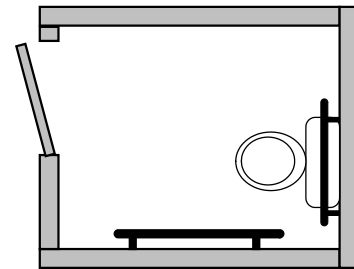

153. The toilet seat is 17 inches to 19 inches high.

- Yes
- No
- N/A

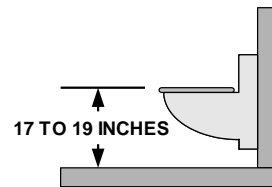

154. There are at least 18 inches of clear space from the center of the toilet to the wall(s) on either side.

- Yes
- No
- N/A

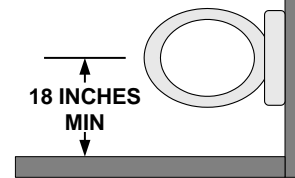

Note: Make measurement to wall. Do not include objects such as toilet paper dispensers in your measurement.

155. The window where urine samples are placed is no higher than 48 inches and is operable with a closed fist.

- Yes
- No
- N/A

The following features are for toilet stalls (where they exist) within lab specimen collection room.

156. Where the toilet is approached from the front and there is a sink alongside the toilet, there is clear floor space of at least 48 inches wide by 66 inches long (toilet wall to opposite wall).

- Yes
- No
- N/A

Note: If door swings inward, measure space clear of door swing. This is easiest done with 2 people.

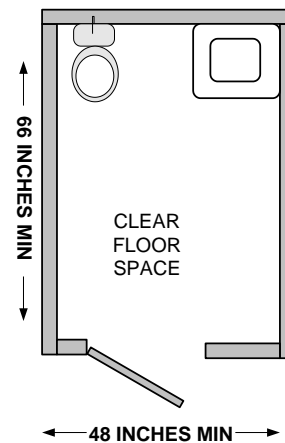

157. Where the toilet is approached from the side and there is a sink alongside the toilet, there is clear floor space of at least 48 inches wide by 56 inches long (toilet wall to opposite wall).

- Yes
- No
- N/A

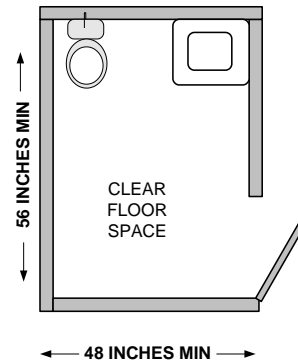

158. Where there is no sink alongside the toilet, there is a clear floor space of at least 60 inches wide by 56 inches long (toilet wall to opposite wall).

- Yes
- No
- N/A

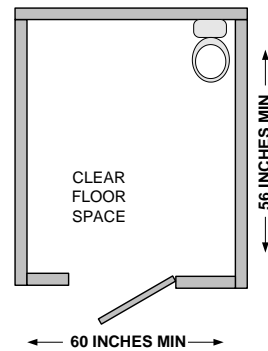

Appendix A: Parking Requirements

Total Parking Spaces:	Required Minimum Number of Spaces:
1 to 25	1
26 to 50	2
51 to 75	3
76 to 100	4
101 to 150	5
151 to 200	6
201 to 300	7
301 to 400	8
401 to 500	9
501 to 1000	2% of total
1001 and over	20 plus 1 for each 100 over 1000

Number of required parking spaces for outpatient units and facilities: 10 percent of the total number of parking spaces provided serving each such outpatient unit or facility.

Appendix B: Overall Scoring Sheet

Your Overall Score

To calculate an overall score, please enter “1” for each item that received a YES or N/A mark next to the corresponding question number below.

Section 1: Patient Arrival	
Parking	
1	
2	
3	
4	
5	
6	
7	
Approach to Building	
8	
9	
10	
11	
12	
13	
14	
15	
16	
17	
Ramps	
18	
19	
20	
21	

22	
23	
Signage	
24	
25	
26	
27	
28	
29	
30	
31	
32	
33	
34	
35	
Controls	
36	
37	
Doors	
38	
39	
40	
41	
42	
43	

Section 2: Public Facilities	
Telephones	
44	
45	
46	
47	
48	
49	
50	
51	
Seating	
52	
Counters	
53	
54	
Passageways	
55	
56	
57	
58	
59	
60	
61	
62	
Water Fountains	
63	
64	
65	
Lifts	
66	
67	
68	

69	
70	
71	
Elevators	
72	
73	
74	
75	
76	
77	
78	
79	
80	
81	
82	
83	
84	
Stairs	
85	
86	
87	
88	
89	
Restrooms	
90	
91	
92	
93	
94	
95	
96	
97	
98	
99	
100	

101	
102	
103	
104	
105	
106	
107	
108	
109	
110	
111	
112	
113	
114	
115	
116	
117	
Emergency Egress	
118	
119	
120	
121	
122	
123	
124	
125	
126	
Section 3: Exam Rooms and Access to Primary Services	
127	
128	
129	
130	

131	
132	
133	
134	
135	
Lab specimen collection rooms	
136	
137	
138	
139	
140	
141	
142	
143	
144	
145	
146	
147	
148	
149	
150	
151	
152	
153	
154	
155	
156	
157	
158	

How to calculate your overall score

Example:

Count how many items you marked YES or N/A. If you answered YES or N/A to 142 items, your calculation would look like this:

$$\boxed{142} \text{ divided by } \boxed{158} \text{ multiplied by } 100 \text{ equals } \boxed{90\%}$$

(items marked YES or N/A) (total survey items) (percent usable)

Your clinic would be 90 percent usable for people with disabilities.

Now enter the total number of yes responses, divide by 158, and multiply by 100 for your score.

$$\boxed{} \div \boxed{158} \times 100 = \boxed{}$$

Appendix C: Mobility Scoring Sheet

Your Mobility Score

To calculate a score for the mobility category, please enter "1" for each item that received a YES or N/A mark next to the corresponding question number below. There are 117 items that count towards the mobility score.

1	
2	
3	
4	
5	
6	
7	
8	
9	
10	
11	
12	
13	
14	
15	
16	
17	
18	
19	
20	
21	
22	
23	
36	
37	
38	

39	
40	
41	
42	
43	
44	
45	
46	
52	
53	
54	
55	
56	
57	
58	
59	
61	
63	
64	
66	
67	
68	
69	
70	
71	
72	
76	

77	
78	
79	
84	
89	
93	
94	
95	
96	
97	
98	
99	
100	
101	
102	
103	
104	
105	
106	
107	
108	
109	
110	
111	
112	
113	
114	
115	
116	
117	
118	
119	
120	
123	
125	

126	
127	
128	
129	
130	
131	
132	
133	
134	
139	
140	
141	
142	
143	
144	
145	
146	
147	
148	
149	
150	
151	
152	
153	
154	
155	
156	
157	
158	
Total items	117

How to calculate your mobility score

Example:

Count how many items you marked YES or N/A. If you answered YES or N/A to 105 items, your calculation would look like this:

$$\boxed{105} \text{ divided by } \boxed{117} \text{ multiplied by } 100 \text{ equals } \boxed{90\%}$$

(items marked YES or N/A) (total survey items) (percent usable)

Your clinic would be 90 percent usable for people with mobility impairments.

Now enter the total number of yes responses, divide by 117, and multiply by 100 for your score.

$$\boxed{} \div \boxed{117} \times 100 = \boxed{}$$

Appendix D: Sensory Scoring Sheet

Your Sensory Score

To calculate a score for the sensory category, please enter "1" for each item that received a YES or N/A mark next to the corresponding question number below. There are 43 items that count towards the sensory score.

24	
25	
26	
27	
28	
29	
30	
31	
32	
33	
34	
35	
47	
48	
49	
50	
51	
60	
62	
65	
73	
74	

75	
76	
78	
80	
81	
82	
83	
85	
86	
87	
88	
90	
91	
92	
121	
122	
123	
124	
136	
137	
138	
Total items:	43

How to calculate your sensory score

Example:

Count how many items you marked YES or N/A. If you answered YES or N/A to 35 items, your calculation would look like this:

$$\begin{array}{ccc} \boxed{39} & \text{divided by} & \boxed{43} & \text{multiplied by 100 equals} & \boxed{90\%} \\ \text{(items marked YES or N/A)} & & \text{(total survey items)} & & \text{(percent usable)} \end{array}$$

Your clinic would be 90 percent usable for people with sensory impairments.

Now enter the total number of yes responses, divide by 43, and multiply by 100 for your score.

$$\boxed{} \div \boxed{43} \times 100 = \boxed{}$$

Appendix E: Cognitive Scoring Sheet

Your Cognitive Score

To calculate a score for the cognitive category, please enter "1" for each item that received a YES or N/A mark next to the corresponding question number below. There are 6 items that count towards the cognitive score.

24	
25	
26	
78	
122	
123	
135	
Total items	6

How to calculate your cognitive score

Example:

Count how many items you marked YES or N/A. If you answered YES or N/A to 6 items, your calculation would look like this:

$$\boxed{6} \text{ divided by } \boxed{7} \text{ multiplied by } 100 \text{ equals } \boxed{90\%}$$

(items marked YES or N/A) (total survey items) (percent usable)

Your clinic would be 90 percent usable for people with cognitive impairments.

Now enter the total number of yes responses, divide by 7, and multiply by 100 for your score.

$$\boxed{} \div \boxed{7} \times 100 = \boxed{}$$

*This publication is
available in
alternate formats
upon request.*

We're on the web!
www.healthwellness.org
